

Angular contact ball bearings

Single row
Double row

Angular contact ball bearings

X-life Single row angular contact ball bearings 260
	In single row angular contact ball bearings, the raceways are arranged such that the forces are transmitted from one raceway to the other at a specific contact angle (oblique to the radial plane). The axial load carrying capacity increases with the contact angle. Due to the large contact angle, single row angular contact ball bearings are more suitable than deep groove ball bearings for supporting large axial forces acting in one direction. Single row angular contact ball bearings can support radial loads and unilateral axial loads. They are adjusted against a second bearing that provides counter guidance.
Double row angular contact ball bearings 280
	Double row angular contact ball bearings are similar in design to a pair of single row angular contact ball bearings in an O arrangement. In this case, the apexes of the cones formed by the ball contact lines point outwards. Double row bearings can support high radial forces as well as axial forces in both directions and are particularly suitable for rigid axial guidance arrangements. Depending on the series, the bearings are designed with or without filling slots.

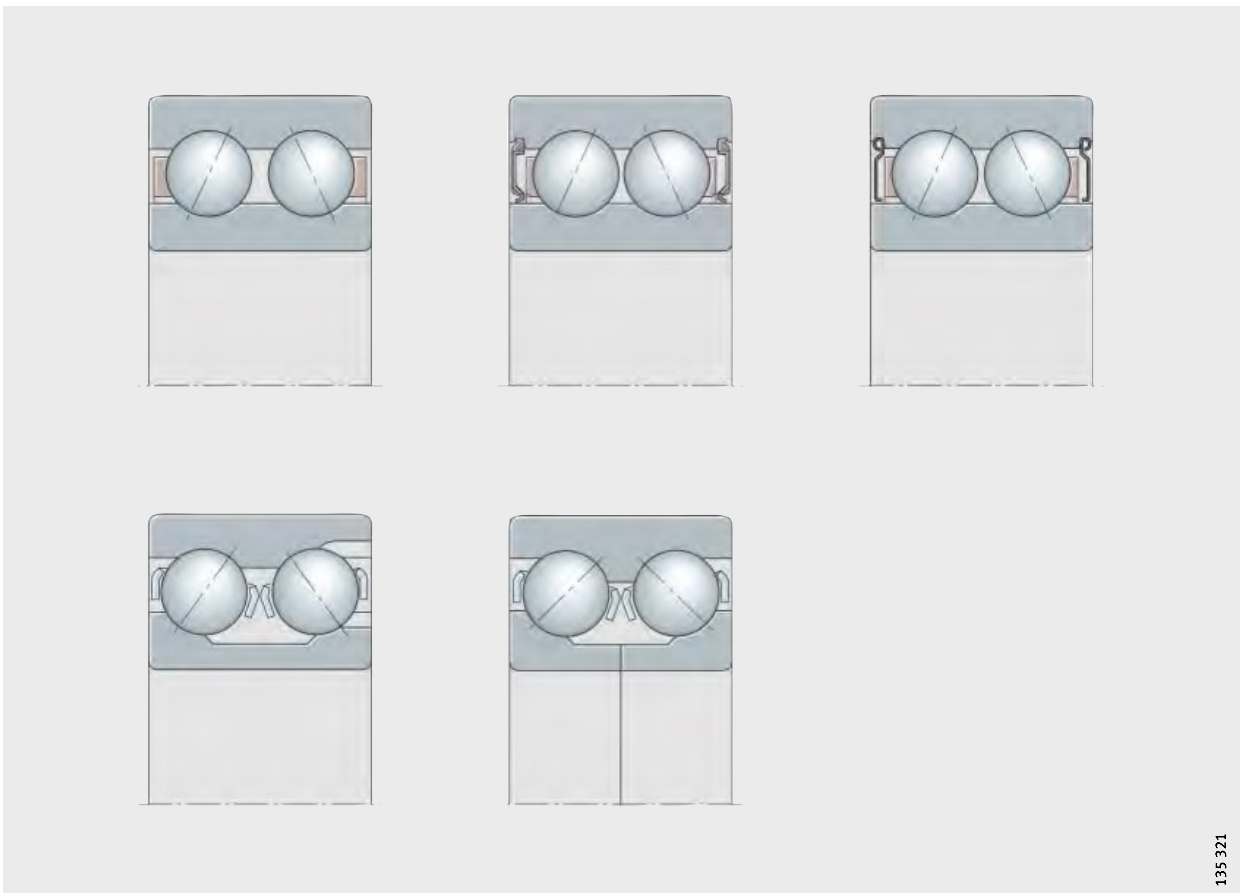

FAG

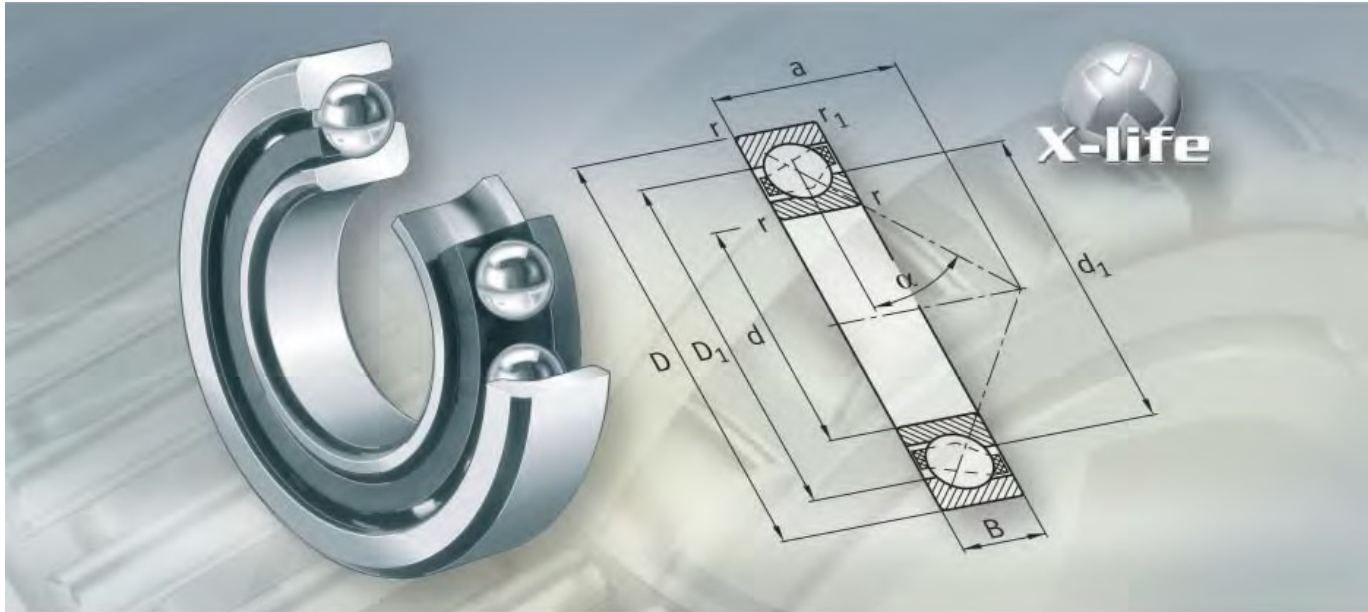

Single row angular contact ball bearings

Single row angular contact ball bearings



		Page
Product overview	Single row angular contact ball bearings	262
Features	X-life	263
	Radial and axial load capacity.....	263
	Operating temperature	264
	Cages.....	264
	Suffixes.....	265
Design and safety guidelines	Calculation of axial force	266
	Equivalent dynamic bearing load	267
	Equivalent static bearing load.....	268
	Basic dynamic and static load ratings for bearing pairs	268
	Minimum radial load	268
	Speeds.....	268
	Design of bearing arrangements	269
Accuracy	Tolerances for universal designs and for matched bearings	269
	Axial internal clearance and preload	270
Dimension tables	Angular contact ball bearings, single row, open or sealed.....	272
	Angular contact ball bearings, single row, open.....	276

Product overview Single row angular contact ball bearings

Single row

718..-B, 70..-B, 72..-B,
73..-B



Lip seals

70..-B-2RS, 72..-B-2RS,
73..-B-2RS

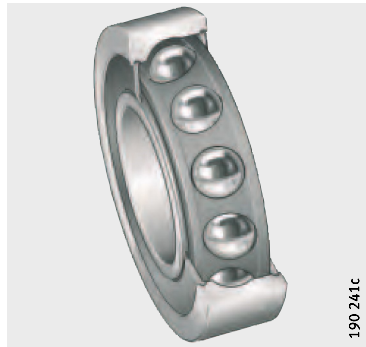

Single row angular contact ball bearings



Features Single row angular contact ball bearings are self-retaining units with solid inner and outer rings and ball and cage assemblies with polyamide, sheet metal or brass cages. The raceways of the inner and outer rings are offset from each other along the bearing axis. The bearings are available in open and sealed designs. Their angular adjustment facility is very limited.

X-life Many sizes of angular contact ball bearings are classified as X-life products. These bearings are indicated in the dimension tables. Bearings of X-life quality have an improved raceway geometry and optimised surfaces. This gives a significant increase in the fatigue limit load of the bearings. When calculating the expanded adjusted rating life, values up to 50% higher are achieved. In certain applications, this means that a smaller bearing arrangement can be designed.

Radial and axial load capacity Single row angular contact ball bearings can support axial forces in one direction and high radial forces. They must be axially adjusted against a second bearing fitted in a mirror image arrangement. The axial load carrying capacity is dependent on the contact angle; i. e. the larger the angle, the higher the load to which the bearing can be subjected. Due to the contact angle of 40°, these bearings can support high axial loads.

Universal design Single row angular contact ball bearings of universal design have the suffix UA, UL or UO and are intended for fitting in pairs in an X, O or tandem arrangement or fitting in groups. These bearings can be fitted in any arrangement required. For tandem arrangements, pay attention to the guidelines in the section Design of bearing arrangements, page 269. The suffix UA indicates small axial internal clearance, the suffix UL indicates slight preload and the suffix UO indicates freedom from clearance in an X or O arrangement. When ordering bearings, the total quantity of bearings must be stated, not the number of bearing pairs or bearing groups.

Matched bearings Sets without an intermediate ring are available in an O arrangement (DB), X arrangement (DF) or tandem arrangement (DT). When ordering bearings, the number of sets must be stated, not the number of single bearings.

Sealing Bearings with the suffix 2RS have lip seals on both sides. Contact RS seals are suitable for giving protection against dust, contamination and damp atmospheres.

Lubrication Bearings with lip seals on both sides are greased with a high quality grease and are lubricated for life. Open bearings and bearings with seals on one side are not greased. They can be lubricated with grease or oil.

Single row angular contact ball bearings

Operating temperature

Open angular contact ball bearings can be used at operating temperatures from -30 °C to $+150\text{ °C}$.

Bearings with a diameter $D > 240\text{ mm}$ are dimensionally stable up to $+200\text{ °C}$.



Angular contact ball bearings with cages made from glass fibre reinforced polyamide are suitable for operating temperatures up to $+120\text{ °C}$, restricted by the cage material.

Sealed bearings are suitable for operating temperatures from -30 °C to $+110\text{ °C}$, restricted by the lubricant and the seal material.

Cages

Angular contact ball bearings with solid cages made from glass fibre reinforced polyamide have the suffix TVP or TVH.

Solid brass cages have the suffix MP.

The bearings are also available with universally applicable sheet steel window cages (suffix JP).



Check the chemical resistance of polyamide to synthetic greases and lubricants with EP additives.

Aged oil and additives in the oil can impair the operating life of plastic cages at high temperatures.

The oil change intervals must be observed.

Cage and bore code

Series	Solid window cage made from polyamide ¹⁾	Solid window cage made from brass ¹⁾	Sheet steel cage ¹⁾
	Bore code		
718..-B	06 to 16	–	–
70..-B	All	–	–
72..-B	up to 20, 22 to 26	21, from 28	up to 22
73..-B	up to 20, 22 to 26	21, from 28	up to 22

¹⁾ Other cage designs are available by agreement.

With such cages, suitability for high speeds and high temperatures as well as the basic load ratings may differ from the values for bearings with standard cages.



Suffixes Suffixes for available designs: see table.

Available designs

Suffix	Description	Design
B	Modified internal construction	Standard
JP	Sheet steel cage	
MP	Solid brass cage	
DB	Two angular contact ball bearings in O arrangement, matched clearance-free	Special design, available by agreement
DF	Two angular contact ball bearings in X arrangement, matched clearance-free	
DT	Two angular contact ball bearings in tandem arrangement, matched	
TVH TVP	Solid cage made from glass fibre reinforced polyamide	Standard
UA	Universal design for fitting in pairs, bearing pair has small axial internal clearance in O and X arrangement	
UL	Universal design for fitting in pairs, bearing pair has slight preload in O and X arrangement	
UO	Universal design for fitting in pairs, bearing pair is clearance-free in O and X arrangement	
P5	Bearing in tolerance class P5	Special design, available by agreement
2RS	Contact seals on both sides	Standard

Single row angular contact ball bearings

Design and safety guidelines Calculation of axial force

Under radial load, an internal axial force is induced in the bearing that must be supported by a second bearing and taken into consideration when calculating the equivalent bearing load.

Depending on the bearing arrangement (O or X arrangement), the axial force must first be determined for bearings adjusted clearance-free without preload, see Load ratio and axial bearing load, page 267 and *Figure 1, Figure 2*.

The following preconditions apply:

- The radial forces act at the central contact points and are positive
- Bearing A is subjected to a radial load F_{rA} , bearing B to F_{rB}
- F is an external axial force acting on bearing A.

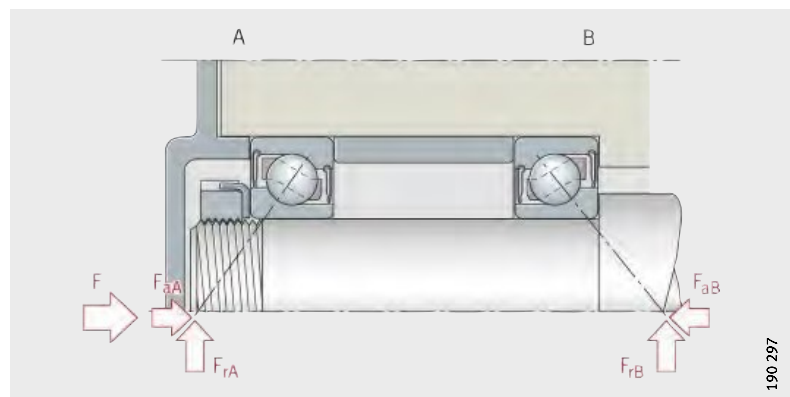

Figure 1
Bearings in O arrangement

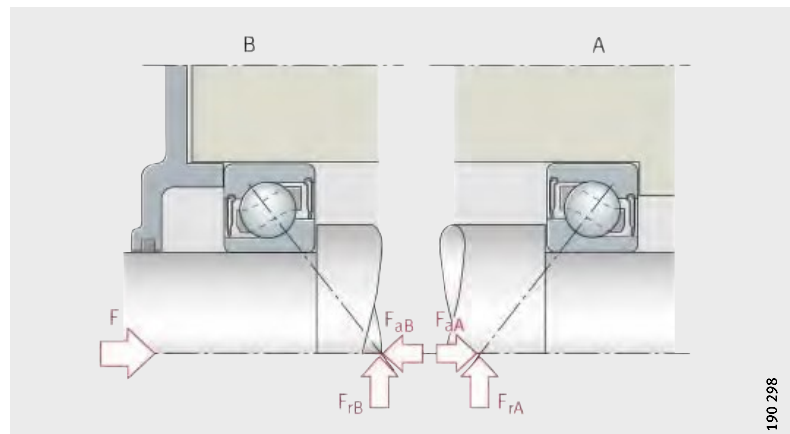

Figure 2
Bearings in X arrangement



Load ratio and axial bearing load

Load ratio ³⁾		Axial force F_a ¹⁾³⁾	
Radial bearing load	External axial force	Bearing A	Bearing B
$\frac{F_{rA}}{Y_A} \leq \frac{F_{rB}}{Y_B}$	$F \geq 0$	$F_a = F + 0,5 \cdot \frac{F_{rB}}{Y_B}$	2)
$\frac{F_{rA}}{Y_A} > \frac{F_{rB}}{Y_B}$	$F > 0,5 \cdot \left(\frac{F_{rA}}{Y_A} - \frac{F_{rB}}{Y_B} \right)$	$F_a = F + 0,5 \cdot \frac{F_{rB}}{Y_B}$	2)
	$F \leq 0,5 \cdot \left(\frac{F_{rA}}{Y_A} - \frac{F_{rB}}{Y_B} \right)$	2)	$F_a = 0,5 \cdot \frac{F_{rA}}{Y_A} - F$

- 1) Axial force F_a , to be used in calculation of the equivalent dynamic bearing load.
- 2) If no formula is given, the axial force is not taken into consideration.
- 3) For bearings of series 718...-B, 70...-B, 72...-B and 73...-B, the axial load component factor for $Y = 0,57$ is used in the formulae.

Equivalent dynamic bearing load

Contact angle 40°

For bearings under dynamic loading, the following applies:

Bearing arrangement	Load ratio	Equivalent dynamic bearing load
Single bearing ¹⁾	$\frac{F_a}{F_r} \leq 1,14$	$P = F_r$
	$\frac{F_a}{F_r} > 1,14$	$P = 0,35 \cdot F_r + 0,57 \cdot F_a$
Bearing pair in O or X arrangement	$\frac{F_a}{F_r} \leq 1,14$	$P = F_r + 0,55 \cdot F_a$
	$\frac{F_a}{F_r} > 1,14$	$P = 0,57 \cdot F_r + 0,93 \cdot F_a$

- 1) Calculation of axial force for single bearings, see table Load ratio and axial bearing load.

P N
 Equivalent dynamic bearing load for combined load
 F_a N
 Axial dynamic bearing load
 F_r N
 Radial dynamic bearing load.

Single row angular contact ball bearings

Equivalent static bearing load

Contact angle 40°

For bearings under static loading, the following applies:

Bearing arrangement	Load ratio	Equivalent static load
Single bearing	$\frac{F_{0a}}{F_{0r}} \leq 1,9$	$P_0 = F_{0r}$
	$\frac{F_{0a}}{F_{0r}} > 1,9$	$P_0 = 0,5 \cdot F_{0r} + 0,26 \cdot F_{0a}$
Bearing pair in O or X arrangement	–	$P_0 = F_{0r} + 0,52 \cdot F_{0a}$

P_0 N
Equivalent static bearing load for combined load
 F_{0a} N
Axial static bearing load
 F_{0r} N
Radial static bearing load.

Basic dynamic and static load ratings for bearing pairs

If two bearings of the same size and design are fitted immediately adjacent to each other in an O or X arrangement, the basic dynamic load rating C_r and basic static load rating C_{0r} of the bearing pair are as follows:

- $C_r = 1,625 \cdot C_{r \text{ single bearing}}$
- $C_{0r} = 2 \cdot C_{0r \text{ single bearing}}$

Minimum radial load

In order to ensure slippage-free operation, the bearings must be subjected to a minimum radial load. This applies particularly in the case of high speeds and high accelerations. In continuous operation, a minimum radial load of the order of $P/C_r > 0,01$ is necessary for ball bearings with cage.

Speeds

For greased and sealed bearings, the speeds are lower than in the case of unsealed bearings.



The limiting speeds n_G given in the dimension tables must not be exceeded.

Bearings in universal design

Bearings with the suffix UA, UL or UO can be used in an X, O or tandem arrangement. The operating speed of the bearing pair is then approximately 20% below the calculated permissible operating speed of the single bearing.

The limiting speed n_G is possible if the less favourable thermal balance of the bearing pair is taken into consideration.



Design of bearing arrangements
Shaft and housing tolerances

Recommended shaft tolerances for radial bearings with cylindrical bore, see tables, page 150.

Recommended housing tolerances for radial bearings, see table, page 152.

Mounting dimensions

The bearing tables give the maximum dimension of the radii r_a and r_{a1} and the diameters of the abutment shoulders D_a , D_b and d_a .

Fitting in tandem arrangement



If single row angular contact bearings are fitted in a tandem arrangement, it must be ensured that the end faces of the outer rings in contact with each other have sufficient overlap.

If in doubt, please contact the Schaeffler engineering service.

Accuracy

The main dimensions of the bearings conform to DIN 628-1.

The dimensional and geometrical tolerances of the bearings correspond to tolerance class PN to DIN 620-2.

Tolerances for universal designs and for matched bearings

Angular contact ball bearings of the universal designs UA, UL or UO are available not only in the normal tolerance (no tolerance suffix) but also by agreement in the tolerance class P5 (suffix P5-UL or P5-UA).

The following exceptions apply: bore tolerances for bearings of all tolerance classes uniformly to P5 (no special suffix), width tolerances for universal bearings and matched bearings, see table.

Tolerance for ring width

Bore d mm		Width deviation			
		Δ_{Bs} μm		P5	
over	incl.	min.	max.	min.	max.
–	50	0	–250	0	–250
50	80	0	–380	0	–250
80	120	0	–380	0	–380
120	180	0	–500	0	–380
180	315	0	–500	0	–500

Single row angular contact ball bearings

Axial internal clearance and preload

Axial internal clearance or preload of series 70..-B, 72..-B and 73..-B of universal design, in pairs in an X or O arrangement, see table.

The axial internal clearance or freedom from clearance do not apply to fitted bearing pairs. If rigid fits are used, this leads to reduced axial internal clearance or increased preload of the bearing pair.

Axial internal clearance and preload

Bore code	Axial internal clearance or preload of bearing pair Nominal dimension μm					Preload $F_{V \max}$ N			
	UA	UO	UL			UL			
	70B, 72B, 73B			70B	72B	73B	70B	72B	73B
	Tolerance classes					Tolerance class			
	PN, P6, P5		P5	P5	P5	P5	P5	P5	
00	22	0	-	-3	-	-	38	-	
01	24	0	-	-4	-5	-	53	82	
02	24	0	-	-4	-5	-	62	99	
03	24	0	-	-4	-6	-	77	123	
04	28	0	-4	-5	-6	103	103	146	
05	34	0	-4	-4	-6	115	112	200	
06	34	0	-5	-5	-7	141	157	250	
07	40	0	-5	-6	-7	172	208	300	
08	40	0	-5	-6	-8	200	246	385	
09	44	0	-	-6	-9	-	277	462	
10	44	0	-	-6	-10	-	288	535	
11	46	0	-	-7	-10	-	358	600	
12	46	0	-	-7	-10	-	431	692	
13	46	0	-	-8	-11	-	492	785	
14	50	0	-	-8	-11	-	535	877	
15	50	0	-	-8	-12	-	523	977	
16	50	0	-	-8	-12	-	615	1 077	
17	54	0	-	-8	-13	-	692	1 154	
18	54	0	-	-9	-13	-	815	1 231	
19	54	0	-	-10	-14	-	892	1 331	
20	54	0	-	-11	-14	-	992	1 485	
21	58	0	-	-11	-14	-	1 100	1 538	
22	58	0	-	-12	-15	-	1 177	1 723	
24	58	0	-	-12	-16	-	1 277	1 923	
26	60	0	-	-12	-17	-	1 431	2 115	
28	60	0	-	-12	-17	-	1 508	2 308	
30	60	0	-	-13	-18	-	1 723	2 500	
32	60	0	-	-13	-18	-	1 815	2 769	
34	70	0	-	-14	-19	-	2 038	3 115	



Tolerances for axial internal clearance or preload

Tolerances for axial internal clearance or preload of pairs of angular contact ball bearings of universal design in X or O arrangement before fitting.

Tolerances

Bore code	Series 70B, 72B		Series 73B	
	Tolerance classes in μm			
	PN, P6	P5	PN, P6	P5
00 to 09	+8	+6	+8	+6
10 to 11	+8	+6	+12	+10
12 to 34	+12	+10	+12	+10

Angular contact ball bearings

Single row
Open or sealed

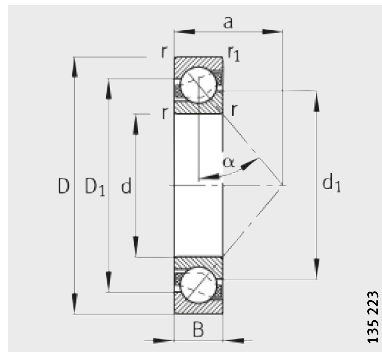

70..-B, 72..-B, 73..-B
 $\alpha = 40^\circ$

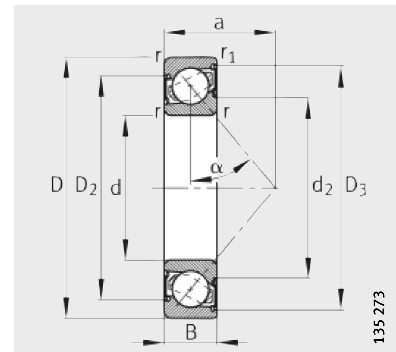

70..-B-2RS, 72..-B-2RS,
73..-B-2RS
Seal 2RS

Dimension table · Dimensions in mm

Designation	X-life	Mass m ≈ kg	Dimensions								
			d	D	B	r	r ₁	D ₁	D ₂	D ₃	d ₁
						min.	min.	≈	≈	≈	≈
7200-B-JP	XL	0,033	10	30	9	0,6	0,3	22,1	–	–	18
7200-B-TVP	XL	0,032	10	30	9	0,6	0,3	22,1	–	–	18
7200-B-2RS-TVP	XL	0,032	10	30	9	0,6	0,3	–	23,3	25,6	–
7201-B-JP	XL	0,038	12	32	10	0,6	0,3	24,6	–	–	19,5
7201-B-TVP	XL	0,035	12	32	10	0,6	0,3	24,6	–	–	19,5
7201-B-2RS-TVP	XL	0,037	12	32	10	0,6	0,3	–	25,9	28,8	–
7301-B-JP	XL	0,066	12	37	12	1	0,6	27,2	–	–	22,1
7301-B-TVP	XL	0,06	12	37	12	1	0,6	27,2	–	–	22,1
7202-B-JP	XL	0,047	15	35	11	0,6	0,3	27,6	–	–	22,5
7202-B-TVP	XL	0,044	15	35	11	0,6	0,3	27,6	–	–	22,5
7202-B-2RS-TVP	XL	0,044	15	35	11	0,6	0,3	–	29,2	32,1	–
7302-B-JP	XL	0,088	15	42	13	1	0,6	31,8	–	–	25,5
7302-B-TVP	XL	0,082	15	42	13	1	0,6	31,8	–	–	25,5
7302-B-2RS-TVP	XL	0,082	15	42	13	1	0,6	–	33,3	38,1	–
7203-B-JP	XL	0,069	17	40	12	0,6	0,3	31,2	–	–	26,2
7203-B-TVP	XL	0,065	17	40	12	0,6	0,3	31,2	–	–	26,2
7203-B-2RS-TVP	XL	0,065	17	40	12	0,6	0,3	–	33,1	36,3	–
7303-B-JP	XL	0,117	17	47	14	1	0,6	35,8	–	–	28,5
7303-B-TVP	XL	0,109	17	47	14	1	0,6	35,8	–	–	28,5
7303-B-2RS-TVP	XL	0,109	17	47	14	1	0,6	–	37,2	42,6	–
7004-B-TVP	XL	0,06	20	42	12	0,6	0,3	34,7	–	–	29,1
7004-B-2RS-TVP	XL	0,061	20	42	12	0,6	0,3	–	37,1	39,8	–
7204-B-JP	XL	0,111	20	47	14	1	0,6	36,6	–	–	30,4
7204-B-TVP	XL	0,104	20	47	14	1	0,6	36,6	–	–	30,4
7204-B-2RS-TVP	XL	0,104	20	47	14	1	0,6	–	39,1	43	–
7304-B-JP	XL	0,152	20	52	15	1,1	0,6	39,9	–	–	32,4
7304-B-TVP	XL	0,143	20	52	15	1,1	0,6	39,9	–	–	32,4
7304-B-2RS-TVP	XL	0,143	20	52	15	1,1	0,6	–	41,4	47,1	–
7005-B-TVP	XL	0,071	25	47	12	0,6	0,3	39,7	–	–	34,1
7005-B-2RS-TVP	XL	0,071	25	47	12	0,6	0,3	–	41,5	44,8	–
7205-B-JP	XL	0,135	25	52	15	1	0,6	41,6	–	–	35,4
7205-B-TVP	XL	0,127	25	52	15	1	0,6	41,6	–	–	35,4
7205-B-2RS-TVP	XL	0,127	25	52	15	1	0,6	–	44,1	48	–
7305-B-JP	XL	0,242	25	62	17	1,1	0,6	48,1	–	–	39,3
7305-B-TVP	XL	0,223	25	62	17	1,1	0,6	48,1	–	–	39,3
7305-B-2RS-TVP	XL	0,231	25	62	17	1,1	0,6	–	50,4	57,1	–

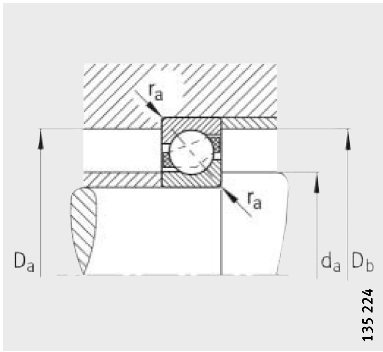

Mounting dimensions

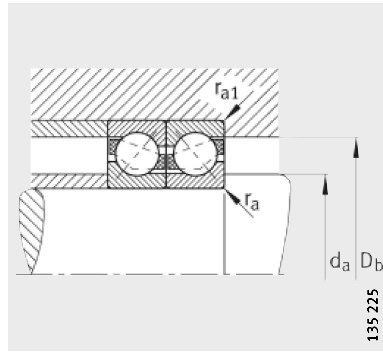

Mounting dimensions

		Mounting dimensions					Basic load ratings		Fatigue limit load C_{ur} N	Limiting speed n_G min ⁻¹	Reference speed n_B min ⁻¹
d_2 ≈	a ≈	d_a min.	D_a max.	D_b max.	r_a max.	r_{a1} max.	dyn. C_r N	stat. C_{0r} N			
-	13	14,2	25,8	27,6	0,6	0,3	5 300	2 600	174	32 000	22 600
-	13	14,2	25,8	27,6	0,6	0,3	5 300	2 600	174	32 000	22 600
15,5	13	14,2	25,8	27,6	0,6	0,3	5 300	2 600	174	15 000	-
-	14	16,2	27,8	29,6	0,6	0,3	7 400	3 550	241	28 000	21 100
-	14	16,2	27,8	29,6	0,6	0,3	7 400	3 550	241	28 000	21 100
17	14	16,2	27,8	29,6	0,6	0,3	7 400	3 550	241	14 000	-
-	16	17,6	31,4	32,8	1	0,6	11 400	5 300	355	24 000	16 300
-	16	17,6	31,4	32,8	1	0,6	11 400	5 300	355	24 000	16 300
-	16	19,2	30,8	32,6	0,6	0,3	8 400	4 450	300	24 000	19 100
-	16	19,2	30,8	32,6	0,6	0,3	8 400	4 450	300	24 000	19 100
19,7	16	19,2	30,8	32,6	0,6	0,3	8 400	4 450	300	12 000	-
-	18	20,6	36,4	37,8	1	0,6	14 200	7 200	485	20 000	14 200
-	18	20,6	36,4	37,8	1	0,6	14 200	7 200	485	20 000	14 200
22,9	18	20,6	36,4	37,8	1	0,6	14 200	7 200	485	11 000	-
-	18	21,2	35,8	37,6	0,6	0,6	10 500	5 700	380	20 000	17 100
-	18	21,2	35,8	37,6	0,6	0,6	10 500	5 700	380	20 000	17 100
22,9	18	21,2	35,8	37,6	0,6	0,6	10 500	5 700	380	11 000	-
-	20	22,6	41,4	42,8	1	0,6	17 600	9 000	610	18 000	12 800
-	20	22,6	41,4	42,8	1	0,6	17 600	9 000	610	18 000	12 800
26,1	20	22,6	41,4	42,8	1	0,6	17 600	9 000	610	9 500	-
-	12	23,2	38,8	40	0,6	0,3	13 400	7 000	470	18 000	14 600
25,9	12	23,2	38,8	40	0,6	0,3	13 400	7 000	470	9 500	-
-	21	25,6	41,4	42,8	1	0,6	14 000	7 800	520	18 000	15 400
-	21	25,6	41,4	42,8	1	0,6	14 000	7 800	520	18 000	15 400
26,8	21	25,6	41,4	42,8	1	0,6	14 000	7 800	520	9 000	-
-	23	27	45	47,8	1	0,6	20 400	11 100	750	17 000	11 500
-	23	27	45	47,8	1	0,6	20 400	11 100	750	17 000	11 500
30	23	27	45	47,8	1	0,6	20 400	11 100	750	8 500	-
-	21	28,2	43,8	45	0,6	0,3	14 900	8 600	580	16 000	12 200
30,9	21	28,2	43,8	45	0,6	0,3	14 900	8 600	580	8 000	-
-	24	30,6	46,4	47,8	1	0,6	15 300	9 000	600	16 000	13 700
-	24	30,6	46,4	47,8	1	0,6	15 300	9 000	600	16 000	13 700
31,8	24	30,6	46,4	47,8	1	0,6	15 300	9 000	600	8 000	-
-	27	32	55	57,8	1	0,6	28 000	15 800	1 070	14 000	9 800
-	27	32	55	57,8	1	0,6	28 000	15 800	1 070	14 000	9 800
35,8	27	32	55	57,8	1	0,6	28 000	15 800	1 070	7 000	-

Angular contact ball bearings

Single row
Open or sealed

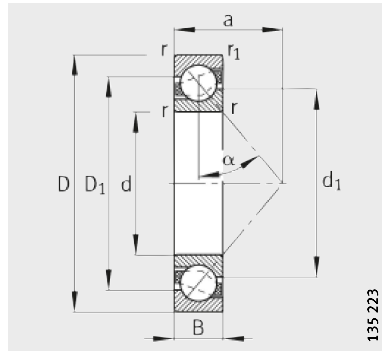

718...-B, 70...-B, 72...-B, 73...-B
 $\alpha = 40^\circ$

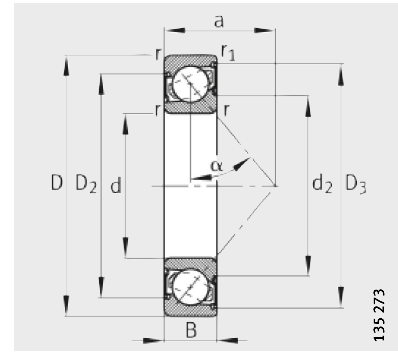

70...-B-2RS, 72...-B-2RS,
73...-B-2RS
Seal 2RS

Dimension table (continued) · Dimensions in mm

Designation	X-life	Mass m ≈ kg	Dimensions								
			d	D	B	r	r ₁	D ₁	D ₂	D ₃	d ₁
						min.	min.	≈	≈	≈	≈
71806-B-TVH	-	0,025	30	42	7	0,3	0,2	37,3	-	-	34,7
7006-B-TVP	XL	0,109	30	55	13	1	0,6	46,9	-	-	40,7
7006-B-2RS-TVP	XL	0,109	30	55	13	1	0,6	-	48,8	53,6	-
7206-B-JP	XL	0,202	30	62	16	1	0,6	49,8	-	-	42,8
7206-B-TVP	XL	0,196	30	62	16	1	0,6	49,8	-	-	42,8
7206-B-2RS-TVP	XL	0,203	30	62	16	1	0,6	-	51,9	57	-
7306-B-JP	XL	0,362	30	72	19	1,1	0,6	56	-	-	46,5
7306-B-TVP	XL	0,341	30	72	19	1,1	0,6	56	-	-	46,5
7306-B-2RS-TVP	XL	0,341	30	72	19	1,1	0,6	-	58,6	65,9	-
71807-B-TVH	-	0,027	35	47	7	0,3	0,2	42,3	-	-	39,7
7007-B-TVP	XL	0,14	35	62	14	1	0,6	53,2	-	-	46,5
7007-B-2RS-TVP	XL	0,14	35	62	14	1	0,6	-	55	60,4	-
7207-B-JP	XL	0,3	35	72	17	1,1	0,6	57,9	-	-	49,5
7207-B-TVP	XL	0,282	35	72	17	1,1	0,6	57,9	-	-	49,5
7207-B-2RS-TVP	XL	0,282	35	72	17	1,1	0,6	-	60,2	66,5	-
7307-B-JP	XL	0,475	35	80	21	1,5	1	63,1	-	-	52,7
7307-B-TVP	XL	0,447	35	80	21	1,5	1	63,1	-	-	52,7
7307-B-2RS-TVP	XL	0,447	35	80	21	1,5	1	-	64,7	73,5	-
71808-B-TVH	-	0,029	40	52	7	0,3	0,2	47,3	-	-	44,7
7008-B-TVP	XL	0,17	40	68	15	1	0,6	58,6	-	-	51,3
7008-B-2RS-TVP	XL	0,17	40	68	15	1	0,6	-	60,5	66,3	-
7208-B-JP	XL	0,387	40	80	18	1,1	0,6	64,7	-	-	55,7
7208-B-TVP	XL	0,367	40	80	18	1,1	0,6	64,7	-	-	55,7
7208-B-2RS-TVP	XL	0,367	40	80	18	1,1	0,6	-	67	73,8	-
7308-B-JP	XL	0,646	40	90	23	1,5	1	71,7	-	-	59,2
7308-B-TVP	XL	0,61	40	90	23	1,5	1	71,7	-	-	59,2
7308-B-2RS-TVP	XL	0,61	40	90	23	1,5	1	-	73,9	83,3	-
71809-B-TVH	-	0,033	45	58	7	0,3	0,2	52,8	-	-	50,2
7209-B-JP	XL	0,428	45	85	19	1,1	0,6	70	-	-	60,5
7209-B-TVP	XL	0,405	45	85	19	1,1	0,6	70	-	-	60,5
7309-B-JP	XL	0,878	45	100	25	1,5	1	79,8	-	-	66,7
7309-B-TVP	XL	0,813	45	100	25	1,5	1	79,8	-	-	66,7

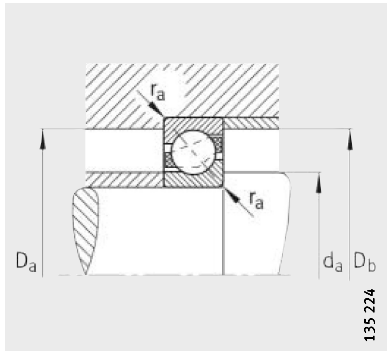

Mounting dimensions

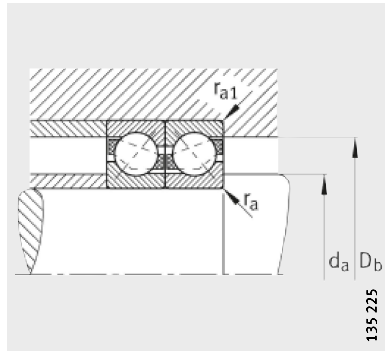

Mounting dimensions



		Mounting dimensions					Basic load ratings		Fatigue limit load	Limiting speed	Reference speed
d ₂	a	d _a	D _a	D _b	r _a	r _{a1}	dyn. C _r	stat. C _{0r}	C _{ur}	n _G	n _B
≈	≈	min.	max.	max.	max.	max.	N	N	N	min ⁻¹	min ⁻¹
–	18,6	32	40	40,6	0,3	0,2	5 600	4 550	295	17 000	–
–	24	34,6	50,4	51,8	1	0,6	18 400	11 500	770	14 000	10 400
38,2	24	34,6	50,4	51,8	1	0,6	18 400	11 500	770	6 700	–
–	27	35,6	56,4	57,8	1	0,6	21 700	14 100	950	13 000	11 200
–	27	35,6	56,4	57,8	1	0,6	21 700	14 100	950	13 000	11 200
39,8	27	35,6	56,4	57,8	1	0,6	21 700	14 100	950	6 300	–
–	31	37	65	67,8	1	0,6	35 500	22 100	1 490	11 000	8 600
–	31	37	65	67,8	1	0,6	35 500	22 100	1 490	11 000	8 600
42,8	31	37	65	67,8	1	0,6	35 500	22 100	1 490	6 000	–
–	20,7	37	45	45,6	0,3	0,2	6 000	5 300	350	15 000	–
–	27	39,6	57,4	58,8	1	0,6	22 400	14 800	1 000	12 000	9 200
44	27	39,6	57,4	58,8	1	0,6	22 400	14 800	1 000	6 000	–
–	31	42	65	67,8	1	0,6	28 000	19 000	1 280	11 000	9 600
–	31	42	65	67,8	1	0,6	28 000	19 000	1 280	11 000	9 600
45,8	31	42	65	67,8	1	0,6	28 000	19 000	1 280	5 600	–
–	35	44	71	74,4	1,5	1	43 000	27 500	1 860	9 500	7 900
–	35	44	71	74,4	1,5	1	43 000	27 500	1 860	9 500	7 900
49,2	35	44	71	74,4	1,5	1	43 000	27 500	1 860	5 000	–
–	22,8	42	50	50,6	0,3	0,2	6 300	5 850	395	13 000	–
–	30	44,6	63,4	64,8	1	0,6	26 000	17 400	1 180	10 000	–
48,8	30	44,6	63,4	64,8	1	0,6	26 000	17 400	1 180	5 300	–
–	34	47	73	75,8	1	0,6	34 000	23 500	1 580	9 500	8 600
–	34	47	73	75,8	1	0,6	34 000	23 500	1 580	9 500	8 600
52	34	47	73	75,8	1	0,6	34 000	23 500	1 580	5 000	–
–	39	49	81	84,4	1,5	1	53 000	34 500	2 320	8 500	7 100
–	39	49	81	84,4	1,5	1	53 000	34 500	2 320	8 500	7 100
55,6	39	49	81	84,4	1,5	1	53 000	34 500	2 320	4 500	–
–	25,1	47	56	56,6	0,3	0,2	6 550	6 550	450	13 000	–
–	37	52	78	80,8	1	0,6	37 500	27 000	1 810	8 500	8 000
–	37	52	78	80,8	1	0,6	37 500	27 000	1 810	8 500	8 000
–	43	54	91	94,4	1,5	1	65 000	43 000	2 900	7 500	6 500
–	43	54	91	94,4	1,5	1	65 000	43 000	2 900	7 500	6 500

Angular contact ball bearings

Single row
Open

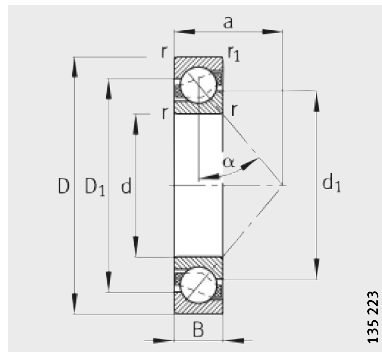

718..-B, 72..-B, 73..-B
 $\alpha = 40^\circ$

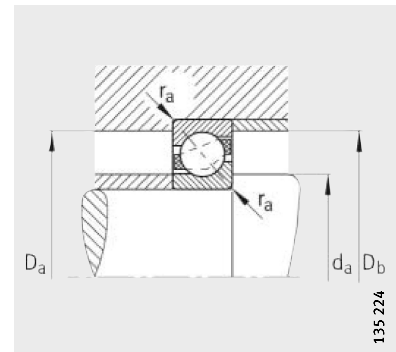

Mounting dimensions

Dimension table (continued) · Dimensions in mm

Designation	X-life	Mass m ≈kg	Dimensions							
			d	D	B	r min.	r ₁ min.	D ₁ ≈	d ₁ ≈	a ≈
71810-B-TVH	-	0,043	50	65	7	0,3	0,2	59,3	56,7	27,8
7210-B-JP	XL	0,493	50	90	20	1,1	0,6	74,8	66,2	39
7210-B-TVP	XL	0,458	50	90	20	1,1	0,6	74,8	66,2	39
7310-B-JP	XL	1,13	50	110	27	2	1	87,6	73,1	47
7310-B-TVP	XL	1,05	50	110	27	2	1	87,6	73,1	47
71811-B-TVH	-	0,058	55	72	9	0,3	0,2	65,3	61,7	31,1
7211-B-JP	XL	0,645	55	100	21	1,5	1	83	72,6	43
7211-B-TVP	XL	0,604	55	100	21	1,5	1	83	72,6	43
7311-B-JP	XL	1,46	55	120	29	2	1	95,3	80,3	51
7311-B-TVP	XL	1,38	55	120	29	2	1	95,3	80,3	51
71812-B-TVH	-	0,07	60	78	10	0,3	0,2	70,8	67,2	33,9
7212-B-JP	XL	0,847	60	110	22	1,5	1	91,1	79,5	47
7212-B-TVP	XL	0,78	60	110	22	1,5	1	91,1	79,5	47
7312-B-JP	XL	1,74	60	130	31	2,1	1,1	103,4	87,3	55
7312-B-TVP	XL	1,72	60	130	31	2,1	1,1	103,4	87,3	55
71813-B-TVH	-	0,085	65	85	10	0,6	0,3	77	73	36,5
7213-B-JP	XL	1,08	65	120	23	1,5	1	98,9	86	51
7213-B-TVP	XL	1	65	120	23	1,5	1	98,9	86	51
7313-B-JP	XL	2,22	65	140	33	2,1	1,1	112	95	60
7313-B-TVP	XL	2,12	65	140	33	2,1	1,1	112	95	60
71814-B-TVH	-	0,091	70	90	10	0,6	0,3	82	78	38,5
7214-B-JP	XL	1,17	70	125	24	1,5	1	104,7	91	53
7214-B-TVP	XL	1,08	70	125	24	1,5	1	104,7	91	53
7314-B-JP	XL	2,76	70	150	35	2,1	1,1	120,1	101,9	64
7314-B-TVP	XL	2,58	70	150	35	2,1	1,1	120,1	101,9	64
71815-B-TVH	-	0,096	75	95	10	0,6	0,3	87	83	40,6
7215-B-JP	XL	1,25	75	130	25	1,5	1	109,2	96,5	56
7215-B-TVP	XL	1,16	75	130	25	1,5	1	109,2	96,5	56
7315-B-JP	XL	3,29	75	160	37	2,1	1,1	128,5	108,8	68
7315-B-TVP	XL	3,1	75	160	37	2,1	1,1	128,5	108,8	68
71816-B-TVH	-	0,101	80	100	10	0,6	0,3	92	88	42,7
7216-B-JP	XL	1,53	80	140	26	2	1	117,8	102,9	59
7216-B-TVP	XL	1,42	80	140	26	2	1	117,8	102,9	59
7316-B-JP	XL	3,86	80	170	39	2,1	1,1	136,7	115,7	72
7316-B-TVP	XL	3,66	80	170	39	2,1	1,1	136,7	115,7	72

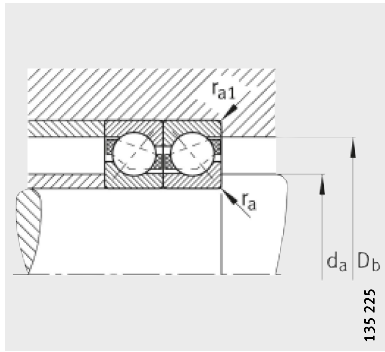

Mounting dimensions



Mounting dimensions					Basic load ratings		Fatigue limit load C_{ur} N	Limiting speed n_G min ⁻¹	Reference speed n_B min ⁻¹
d_a min.	D_a max.	D_b max.	r_a max.	r_{a1} max.	dyn. C_r N	stat. C_{Or} N			
52	63	63,6	0,3	0,2	6 950	7 350	520	9 500	–
57	83	85,8	1	0,6	39 000	28 500	1 920	8 000	7 600
57	83	85,8	1	0,6	39 000	28 500	1 920	8 000	7 600
61	99	104,4	2	1	75 000	50 000	3 400	7 000	6 100
61	99	104,4	2	1	75 000	50 000	3 400	7 000	6 100
57	70	70,6	0,3	0,2	11 800	11 800	760	9 000	–
64	91	94,4	1,5	1	49 000	38 500	2 600	7 000	6 800
64	91	94,4	1,5	1	49 000	38 500	2 600	7 000	6 800
66	109	114,4	2	1	86 000	61 000	4 100	6 300	5 600
66	109	114,4	2	1	86 000	61 000	4 100	6 300	5 600
62	76	76,6	0,3	0,2	12 200	12 900	840	8 000	–
69	101	104,4	1,5	1	59 000	45 000	3 050	6 300	6 200
69	101	104,4	1,5	1	59 000	45 000	3 050	6 300	6 200
72	118	123	2,1	1	96 000	69 000	4 650	5 600	5 300
72	118	123	2,1	1	96 000	69 000	4 650	5 600	5 300
68,2	81,8	83	0,6	0,3	15 300	16 000	970	7 500	–
74	111	114,4	1,5	1	67 000	55 000	3 700	6 000	5 700
74	111	114,4	1,5	1	67 000	55 000	3 700	6 000	5 700
77	128	133	2,1	1	110 000	82 000	5 400	5 300	5 000
77	128	133	2,1	1	110 000	82 000	5 400	5 300	5 000
73,2	86,8	88	0,6	0,3	16 000	17 300	1 070	7 000	–
79	116	119,4	1,5	1	74 000	62 000	4 200	5 600	5 400
79	116	119,4	1,5	1	74 000	62 000	4 200	5 600	5 400
82	138	143	2,1	1	126 000	93 000	6 000	5 000	4 750
82	138	143	2,1	1	126 000	93 000	6 000	5 000	4 750
78,2	91,8	93	0,6	0,3	16 300	18 000	1 140	6 300	–
84	121	124,4	1,5	1	73 000	62 000	4 100	5 300	5 300
84	121	124,4	1,5	1	73 000	62 000	4 100	5 300	5 300
87	148	153	2,1	1	140 000	107 000	6 700	4 500	4 500
87	148	153	2,1	1	140 000	107 000	6 700	4 500	4 500
83,2	96,8	98	0,6	0,3	16 600	19 000	1 200	6 000	–
91	129	134,4	2	1	85 000	72 000	4 650	5 000	4 950
91	129	134,4	2	1	85 000	72 000	4 650	5 000	4 950
92	158	163	2,1	1	155 000	124 000	7 500	4 300	4 250
92	158	163	2,1	1	155 000	124 000	7 500	4 300	4 250

Angular contact ball bearings

Single row
Open

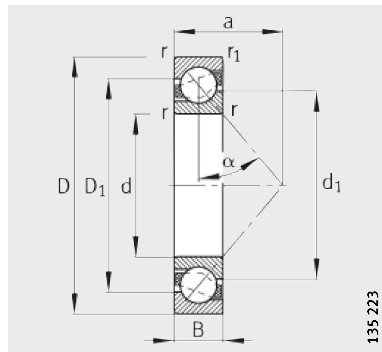

72...B, 73...-B
 $\alpha = 40^\circ$

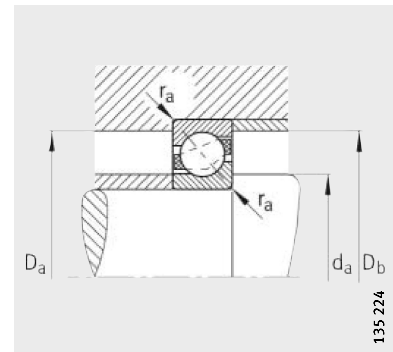

Mounting dimensions

Dimension table (continued) · Dimensions in mm

Designation	X-life	Mass m ≈ kg	Dimensions							
			d	D	B	r min.	r ₁ min.	D ₁ ≈	d ₁ ≈	a ≈
7217-B-JP	XL	1,94	85	150	28	2	1	125	110,6	63
7217-B-TVP	XL	1,82	85	150	28	2	1	125	110,6	63
7317-B-JP	XL	4,4	85	180	41	3	1,1	144	122	76
7317-B-TVP	XL	4,26	85	180	41	3	1,1	144	122	76
7218-B-JP	XL	2,38	90	160	30	2	1	133,4	117,5	67
7218-B-TVP	XL	2,21	90	160	30	2	1	133,4	117,5	67
7318-B-JP	XL	5,14	90	190	43	3	1,1	153	129,7	80
7318-B-TVP	XL	5	90	190	43	3	1,1	153	129,7	80
7219-B-JP	XL	2,64	95	170	32	2,1	1,1	142	124,9	72
7219-B-TVP	XL	2,64	95	170	32	2,1	1,1	142	124,9	72
7319-B-JP	XL	5,93	95	200	45	3	1,1	160,1	136,7	84
7319-B-TVP	XL	5,78	95	200	45	3	1,1	160,1	136,7	84
7220-B-JP	XL	3,45	100	180	34	2,1	1,1	149,6	131,9	76
7220-B-TVP	XL	3,17	100	180	34	2,1	1,1	149,6	131,9	76
7320-B-JP	XL	7,38	100	215	47	3	1,1	172,3	145,8	90
7320-B-TVP	XL	7,16	100	215	47	3	1,1	172,3	145,8	90
7221-B-MP	XL	4,18	105	190	36	2,1	1,1	157,7	138,2	80
7321-B-MP	XL	9	105	225	49	3	1,1	179,6	153,5	94
7222-B-JP	XL	4,7	110	200	38	2,1	1,1	165,7	144,9	84
7222-B-TVP	XL	4,44	110	200	38	2,1	1,1	165,7	144,9	84
7322-B-JP	XL	9,97	110	240	50	3	1,1	191,5	161,9	98
7322-B-TVP	XL	9,74	110	240	50	3	1,1	191,5	161,9	98
7224-B-TVP	XL	5,31	120	215	40	2,1	1,1	179,5	157,2	90
7324-B-TVP	XL	12,5	120	260	55	3	1,1	207,7	175,9	107
7226-B-TVP	XL	6,12	130	230	40	3	1,1	191,8	169,2	96
7326-B-TVP	XL	15,1	130	280	58	4	1,5	222,5	188,5	115
7228-B-MP	XL	8,55	140	250	42	3	1,1	207,5	183,5	103
7328-B-MP	-	20,5	140	300	62	4	1,5	240,2	203,9	123
7230-B-MP	XL	10,9	150	270	45	3	1,1	223,5	197,5	111
7330-B-MP	-	24,8	150	320	65	4	1,5	256,5	217,8	131
7232-B-MP	-	13,5	160	290	48	3	1,1	238	212	118
7332-B-MP	-	29	160	340	68	4	1,5	272,2	232,4	139
7234-B-MP	-	16,7	170	310	52	4	1,5	256,5	226,9	127
7334-B-MP	-	34,4	170	360	72	4	1,5	291,6	248,4	147

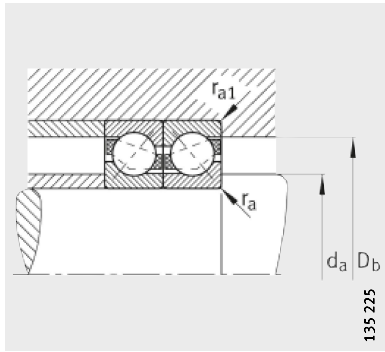

Mounting dimensions



Mounting dimensions					Basic load ratings		Fatigue limit load C_{ur} N	Limiting speed n_G min^{-1}	Reference speed n_B min^{-1}
d_a min.	D_a max.	D_b max.	r_a max.	r_{a1} max.	dyn. C_r N	stat. C_{Or} N			
96	139	144,4	2	1	97 000	86 000	5 300	4 500	4 750
96	139	144,4	2	1	97 000	86 000	5 300	4 500	4 750
99	166	173	2,5	1	167 000	138 000	8 100	4 000	4 100
99	166	173	2,5	1	167 000	138 000	8 100	4 000	4 100
101	149	154,4	2	1	114 000	98 000	5 900	4 300	4 550
101	149	154,4	2	1	114 000	98 000	5 900	4 300	4 550
104	176	183	2,5	1	180 000	155 000	8 800	3 800	3 900
104	176	183	2,5	1	180 000	155 000	8 800	3 800	3 900
107	158	163	2,1	1	123 000	106 000	6 200	4 000	4 500
107	158	163	2,1	1	123 000	106 000	6 200	4 000	4 450
109	186	193	2,5	1	189 000	167 000	9 300	3 800	3 800
109	186	193	2,5	1	189 000	167 000	9 300	3 800	3 800
112	168	173	2,1	1	148 000	132 000	7 500	3 800	4 200
112	168	173	2,1	1	142 000	124 000	7 100	3 800	4 250
114	201	208	2,5	1	214 000	197 000	10 600	3 600	3 550
114	201	208	2,5	1	214 000	197 000	10 600	3 600	3 550
117	178	183	2,1	1	155 000	142 000	7 900	6 000	4 100
119	211	218	2,5	1	225 000	214 000	11 200	5 300	3 400
122	188	193	2,1	1	167 000	154 000	8 300	3 600	3 950
122	188	193	2,1	1	167 000	154 000	8 300	3 600	3 950
124	226	233	2,5	1	250 000	245 000	12 500	3 400	3 150
124	226	233	2,5	1	250 000	245 000	12 500	3 400	3 150
132	203	208	2,1	1	182 000	178 000	9 300	3 400	3 700
134	246	253	2,5	1	275 000	285 000	13 900	3 200	2 850
144	216	223	2,5	1	200 000	204 000	10 300	3 200	3 350
147	263	271	3	1,5	305 000	325 000	15 400	3 000	2 600
154	236	243	2,5	1	214 000	231 000	11 100	4 800	3 100
157	283	291	3	1,5	300 000	345 000	12 700	4 300	2 400
164	256	263	2,5	1	245 000	275 000	12 800	4 500	2 850
167	303	311	3	1,5	325 000	390 000	14 200	3 800	2 200
174	276	283	2,5	1	236 000	280 000	10 400	4 300	2 650
177	323	331	3	1,5	360 000	450 000	15 100	3 600	2 040
187	293	301	3	1,5	265 000	325 000	11 600	3 800	2 440
187	343	351	3	1,5	405 000	530 000	18 100	3 200	1 840

FAG

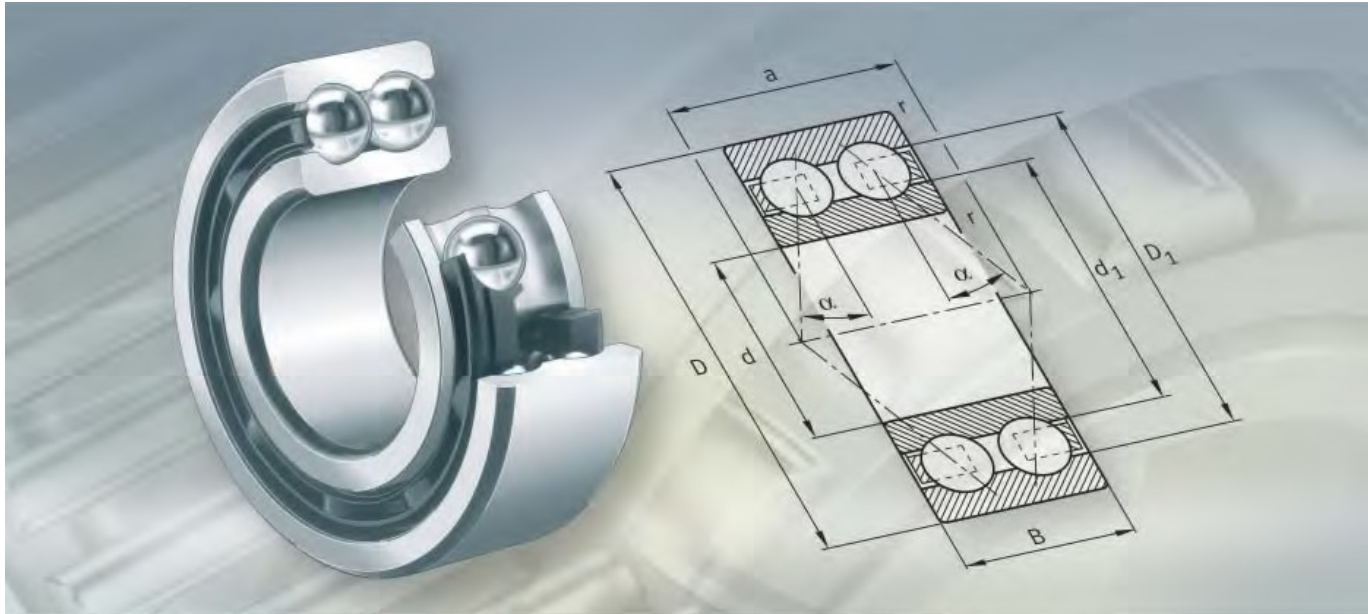

Double row angular contact ball bearings

Double row angular contact ball bearings



	Page
Product overview	Double row angular contact ball bearings..... 282
Features	Radial and axial load capacity..... 283
	Operating temperature 284
	Cages..... 284
	Suffixes..... 285
Design and safety guidelines	Equivalent dynamic bearing load 285
	Equivalent static bearing load..... 286
	Minimum radial load 286
	Speed 286
	Design of bearing arrangements 286
Accuracy	Axial internal clearance 287
Dimension tables	Angular contact ball bearings, double row, open or sealed 288
	Angular contact ball bearings, double row, open or sealed, split inner ring..... 292

Product overview Double row angular contact ball bearings

Double row

38..-B, 30..-B, 32..-B, 33..-B

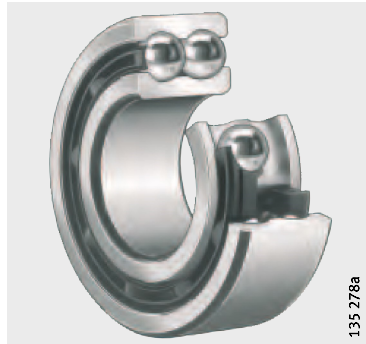

Lip seals or gap seals

38..-B-2RSR, 30..-B-2RSR,
32..-B-2RSR, 33..-B-2RSR

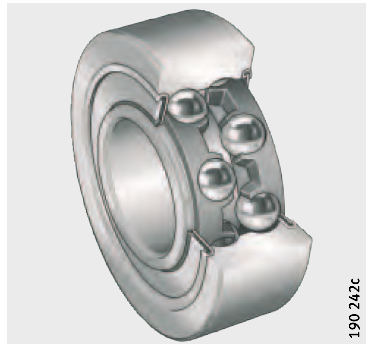

38..-B-2Z, 30..-B-2Z,
32..-B-2Z, 33..-B-2Z

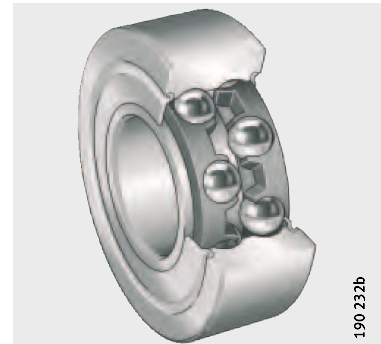

With filling slot

32, 33



Split inner ring

33..-DA



Double row angular contact ball bearings



Features Double row angular contact ball bearings are units with solid inner and outer rings and ball and cage assemblies with polyamide, sheet steel or brass cages. Their construction is similar to a pair of single row angular contact ball bearings in an O arrangement but they are narrower to a certain extent. They differ in the size of the contact angle and the design of the bearing rings.

The bearings are available in open and sealed designs. Due to the manufacturing processes used, open bearings can have turned recesses in the outer ring for seals or shields. Sealed bearings are maintenance-free and therefore allow particularly economical bearing arrangements.

The angular adjustment facility of the angular contact ball bearings is very limited.

Radial and axial load capacity Double row angular contact ball bearings can support axial forces in both directions and high radial forces. They are particularly suitable for bearing arrangements where rigid axial guidance is required.

The axial load carrying capacity is dependent on the contact angle; i.e. the larger the angle ($\alpha = 25^\circ, 35^\circ$ and 45°), the higher the axial load to which the bearing can be subjected.

Without filling slot Bearings of series 38..-B, 30..-B, 32..-B and 33..-B are self-retaining and do not have filling slots in the end faces of the bearing rings. They have a contact angle of $\alpha = 25^\circ$. Their axial load carrying capacity is the same in both directions. These bearings are highly versatile.

With filling slot Angular contact ball bearings of series 32 und 33 are self-retaining and have filling slots on one side. They have a contact angle of $\alpha = 35^\circ$.



These series must be fitted such that the main load direction is supported by the raceways without filling slots.

With split inner ring Bearings of series 33..-DA have a split inner ring. Due to the contact angle of $\alpha = 45^\circ$, they can support very high axial forces in both directions.

The inner ring halves are matched to the particular bearing and must not be interchanged with those of other bearings of the same size.

Sealing Series 38..-B, 30..-B, 32..-B and 33..-B with the suffix 2RSR are sealed by lip seals on both sides. Contact seals are suitable for giving protection against dust, contamination and damp atmospheres.

Series with the suffix 2Z have gap seals on both sides.

Lubrication Sealed bearings are greased with a high quality grease and are lubricated for life.

Double row angular contact ball bearings

Operating temperature

Open bearings are suitable for operating temperatures from -30 °C to $+150\text{ °C}$.



Bearings with cages made from glass fibre reinforced polyamide are suitable for operating temperatures up to $+120\text{ °C}$, restricted by the cage material.

Bearings with the suffix 2RSR are suitable up to $+110\text{ °C}$, restricted by the lubricant and seal material.

Cages

Bearings without a cage suffix have standard cages made from sheet steel.

Angular contact ball bearings with cages made from glass fibre reinforced polyamide have the suffix TVH.

Bearings with ball-guided solid brass cages are indicated by the suffix M. Solid brass cages guided on the outer ring have the suffix MA.



Check the chemical resistance of polyamide to synthetic greases and lubricants with EP additives.

Aged oil and additives in the oil can impair the operating life of plastic cages at high temperatures.

The oil change intervals must be observed.

Cage and bore code

Series	Polyamide cage ¹⁾	Solid brass cage ¹⁾	Sheet steel cage ¹⁾
	Bore code		
32	–	19, 21, 22	17, 18, 20
33	–	17, 19, 20, 22	14 to 16, 18
30..-B	up to 08	–	–
32..-B	up to 16	–	–
33..-B	up to 13	–	–
38..-B	up to 16	–	–
33..-DA	05	08, 10, 11	06, 09, from 12

¹⁾ Other cage designs are available by agreement.

With such cages, suitability for high speeds and high temperatures as well as the basic load ratings may differ from the values for bearings with standard cages.



Suffixes

Suffixes for available designs: see table.

Available designs

Suffix	Description	Design
B	Modified internal construction, contact angle $\alpha = 25^\circ$, without filling slot	Standard
C2	Axial internal clearance C2	Special design, available by agreement
C3	Axial internal clearance C3	
DA	Inner ring split	Standard
M	Solid brass cage, ball-guided	
MA	Solid brass cage, guidance on outer ring	
TVH	Solid polyamide snap cage, ball-guided	
2RSR	Lip seals on both sides	
2Z	Gap seals on both sides	

Design and safety guidelines

Equivalent dynamic bearing load

Contact angle 25°

For bearings under dynamic loading, the following applies:

Load ratio	Equivalent dynamic load
$\frac{F_a}{F_r} \leq 0,68$	$P = F_r + 0,92 \cdot F_a$
$\frac{F_a}{F_r} > 0,68$	$P = 0,67 \cdot F_r + 1,41 \cdot F_a$

Contact angle 35°

Load ratio	Equivalent dynamic load
$\frac{F_a}{F_r} \leq 0,95$	$P = F_r + 0,66 \cdot F_a$
$\frac{F_a}{F_r} > 0,95$	$P = 0,6 \cdot F_r + 1,07 \cdot F_a$

Contact angle 45°

Load ratio	Equivalent dynamic load
$\frac{F_a}{F_r} \leq 1,33$	$P = F_r + 0,47 \cdot F_a$
$\frac{F_a}{F_r} > 1,33$	$P = 0,54 \cdot F_r + 0,81 \cdot F_a$

Symbols, units and definitions

P N
Equivalent dynamic bearing load for combined load
 F_a N
Axial dynamic bearing load
 F_r N
Radial dynamic bearing load.

Double row angular contact ball bearings

Equivalent static bearing load

For bearings under static loading, the following applies:

Contact angle 25°

$$P_0 = F_{0r} + 0,76 \cdot F_{0a}$$

Contact angle 35°

$$P_0 = F_{0r} + 0,58 \cdot F_{0a}$$

Contact angle 45°

$$P_0 = F_{0r} + 0,44 \cdot F_{0a}$$

Symbols, units and definitions

P_0	N
Equivalent static bearing load for combined load	
F_{0a}	N
Axial static bearing load	
F_{0r}	N
Radial static bearing load.	

Minimum radial load

In order to ensure slippage-free operation, the bearings must be subjected to a minimum radial load. This applies particularly in the case of high speeds and high accelerations. In continuous operation, a minimum radial load of the order of $P/C_r > 0,01$ is necessary for ball bearings with cage.

Speed

The reference speed n_B can be exceeded up to the limiting speed n_G if permitted by the operating conditions. If the reference speed in the tables is higher than the limiting speed, the higher value cannot be used.

In bearings with lip seals 2RSR, the speed is limited by the permissible sliding speed of the sealing lips, so only the limiting speed is given in the dimension tables.



The limiting speed n_G given in the dimension tables must not be exceeded.

Design of bearing arrangements Shaft and housing tolerances

Recommended shaft tolerances for radial bearings with cylindrical bore, see table, page 150.

Recommended housing tolerances for radial bearings, see table, page 152.

Mounting dimensions

The dimension tables give the maximum dimension of the radius r_a and the diameters of the abutment shoulders D_a and d_a .



Accuracy The main dimensions of the bearings conform to DIN 628-3. The dimensional and geometrical tolerances of the bearings correspond to tolerance class PN to DIN 620-2.

Axial internal clearance Double row angular contact ball bearings of the basic design have the normal axial internal clearance (CN). Bearings are available by agreement with an axial internal clearance larger (C3) or smaller (C2) than normal.

Bearings with a split inner ring are intended for higher axial loads. In general, they have a tighter fit than unsplit bearings. Their normal internal clearance corresponds to internal clearance group C3 for unsplit bearings.

Axial internal clearance to DIN 628-3 for bearings with unsplit inner ring

Bore d mm		Axial internal clearance					
		C2 μm		CN μm		C3 μm	
over	incl.	min.	max.	min.	max.	min.	max.
–	10	1	11	5	21	12	28
10	18	1	12	6	23	13	31
18	24	2	14	7	25	16	34
24	30	2	15	8	27	18	37
30	40	2	16	9	29	21	40
40	50	2	18	11	33	23	44
50	65	3	22	13	36	26	48
65	80	3	24	15	40	30	54
80	100	3	26	18	46	35	63
100	120	4	30	22	53	42	73

Axial internal clearance for bearings with split inner ring

Bore d mm		Axial internal clearance					
		C2 μm		CN μm		C3 μm	
over	incl.	min.	max.	min.	max.	min.	max.
24	30	8	27	16	35	27	46
30	40	9	29	18	38	30	50
40	50	11	33	22	44	36	58
50	65	13	36	25	48	40	63
65	80	15	40	29	54	46	71

Angular contact ball bearings

Double row
Open or sealed

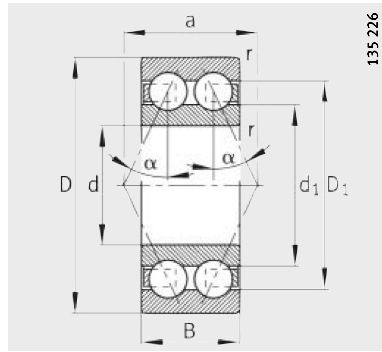

30..-B, 38..-B, 32..-B
 $\alpha = 25^\circ$

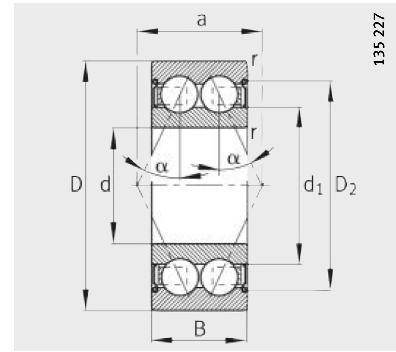

30..-B-2Z, 38..-B-2Z, 32-B-2Z
 $\alpha = 25^\circ$

Dimension table · Dimensions in mm

Designation	Mass m ≈kg	Dimensions							
		d	D	B	r min.	D ₁ ≈	D ₂ ≈	d ₁ ≈	a ≈
30/5-B-TVH	0,008	5	14	7	0,2	–	–	7,5	6,3
30/5-B-2Z-TVH	0,008	5	14	7	0,2	–	–	7,5	6,3
30/5-B-2RSR-TVH	0,008	5	14	7	0,2	–	–	7,5	6,3
30/6-B-TVH	0,01	6	17	9	0,3	–	–	8,3	8,8
30/6-B-2Z-TVH	0,01	6	17	9	0,3	–	–	8,3	8,8
30/6-B-2RSR-TVH	0,01	6	17	9	0,3	–	–	8,3	8,8
30/7-B-TVH	0,012	7	19	10	0,3	–	–	9	10
30/7-B-2Z-TVH	0,012	7	19	10	0,3	–	–	9	10
30/7-B-2RSR-TVH	0,012	7	19	10	0,3	–	–	9	10
30/8-B-TVH	0,02	8	22	11	0,3	–	–	10,5	10,7
30/8-B-2Z-TVH	0,02	8	22	11	0,3	–	–	10,5	10,7
30/8-B-2RSR-TVH	0,02	8	22	11	0,3	–	–	10,5	10,7
3800-B-TVH	0,008	10	19	7	0,3	–	–	13	8,1
3800-B-2Z-TVH	0,008	10	19	7	0,3	–	–	13	8,1
3800-B-2RSR-TVH	0,008	10	19	7	0,3	–	–	13	8,1
3000-B-TVH	0,022	10	26	12	0,3	–	–	13,5	12,3
3000-B-2Z-TVH	0,022	10	26	12	0,3	–	–	13,5	12,3
3000-B-2RSR-TVH	0,022	10	26	12	0,3	–	–	13,5	12,3
3200-B-TVH	0,05	10	30	14	0,6	23,9	–	17,9	15
3200-B-2Z-TVH	0,051	10	30	14	0,6	–	25,3	17,9	15
3801-B-TVH	0,008	12	21	7	0,3	–	–	15	8,9
3801-B-2Z-TVH	0,008	12	21	7	0,3	–	–	15	8,9
3801-B-2RSR-TVH	0,008	12	21	7	0,3	–	–	15	8,9
3001-B-TVH	0,025	12	28	12	0,3	–	–	15,5	13
3001-B-2Z-TVH	0,025	12	28	12	0,3	–	–	15,5	13
3001-B-2RSR-TVH	0,025	12	28	12	0,3	–	–	15,5	13
3201-B-TVH	0,051	12	32	15,9	0,6	25,7	–	18,3	17
3201-B-2Z-TVH	0,053	12	32	15,9	0,6	–	28,1	18,3	17

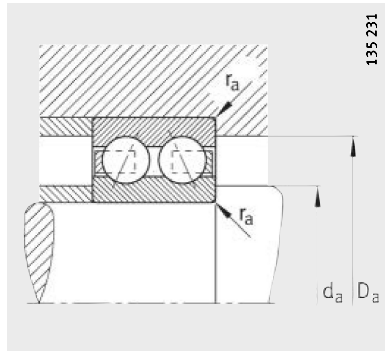
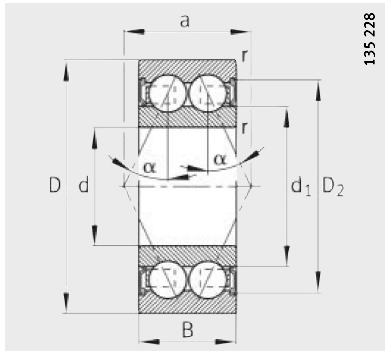

30.-B-2RSR, 32-B-2RSR,
38.-B-2RSR
 $\alpha = 25^\circ$

Mounting dimensions

Mounting dimensions			Basic load ratings		Fatigue limit load	Limiting speed	Reference speed
d_a	D_a	r_a	dyn. C_r	stat. C_{or}	C_{ur}	n_G	n_B
min.	max.	max.	N	N	N	min^{-1}	min^{-1}
6,4	12,6	0,2	1 810	950	48,5	30 000	32 000
6,4	12,6	0,2	1 810	950	48,5	24 000	32 000
6,4	12,6	0,2	1 810	950	48,5	15 000	–
8	15	0,3	3 100	1 420	72	28 000	32 000
8	15	0,3	3 100	1 420	72	22 000	32 000
8	15	0,3	3 100	1 420	72	15 000	–
9	17	0,3	3 650	1 700	86	26 000	31 500
9	17	0,3	3 650	1 700	86	20 000	31 500
9	17	0,3	3 650	1 700	86	15 000	–
10	20	0,3	5 200	2 650	133	26 000	26 000
10	20	0,3	5 200	2 650	133	19 000	26 000
10	20	0,3	5 200	2 650	133	14 000	–
12	17	0,3	2 120	1 400	71	26 000	21 100
12	17	0,3	2 120	1 400	71	18 000	21 100
12	17	0,3	2 120	1 400	71	16 000	–
12	24	0,3	5 700	3 250	164	24 000	22 100
12	24	0,3	5 700	3 250	164	17 000	22 100
12	24	0,3	5 700	3 250	164	14 000	–
14,2	25,8	0,6	7 800	4 550	223	22 000	19 300
14,2	25,8	0,6	7 800	4 550	223	16 000	19 300
14	19	0,3	2 190	1 550	79	24 000	18 100
14	19	0,3	2 190	1 550	79	17 000	18 100
14	19	0,3	2 190	1 550	79	15 000	–
14	26	0,3	6 200	3 750	191	22 000	19 400
14	26	0,3	6 200	3 750	191	16 000	19 400
14	26	0,3	6 200	3 750	191	13 000	–
16,2	27,8	0,6	10 600	5 850	295	20 000	20 000
16,2	27,8	0,6	10 600	5 850	295	15 000	20 000

Angular contact ball bearings

Double row
Open or sealed

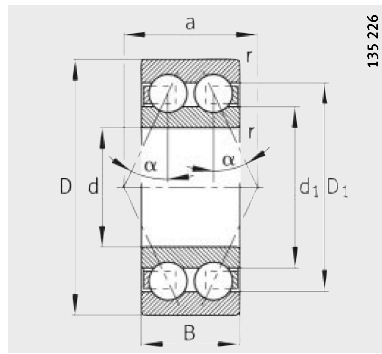

38...-B, 30...-B, 32...-B, 33...-B
 $\alpha = 25^\circ$

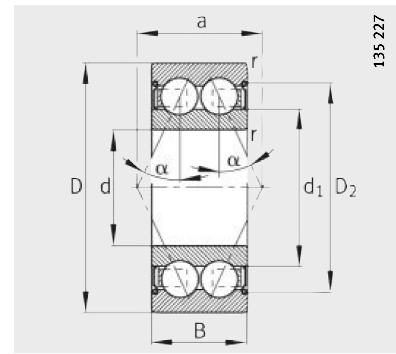

38...-B-2Z, 30...-B-2Z,
32...-B-2Z, 33...-B-2Z
 $\alpha = 25^\circ$

Dimension table (continued) · Dimensions in mm

Designation	Mass m ≈kg	Dimensions							
		d	D	B	r	D ₁	D ₂	d ₁	a
					min.	≈	≈	≈	≈
3802-B-TVH	0,009	15	24	7	0,3	–	–	18	10,1
3802-B-2Z-TVH	0,009	15	24	7	0,3	–	–	18	10,1
3802-B-2RSR-TVH	0,009	15	24	7	0,3	–	–	18	10,1
3002-B-TVH	0,036	15	32	13	0,3	–	–	20,4	14,8
3002-B-2Z-TVH	0,036	15	32	13	0,3	–	–	20,4	14,8
3002-B-2RSR-TVH	0,036	15	32	13	0,3	–	–	20,4	14,8
3202-B-TVH	0,065	15	35	15,9	0,6	28,8	–	21,1	18
3202-B-2Z-TVH	0,067	15	35	15,9	0,6	–	30,9	21,1	18
3202-B-2RSR-TVH	0,067	15	35	15,9	0,6	–	30,9	21,1	18
3302-B-TVH	0,124	15	42	19	1	34,5	–	25,6	21
3803-B-TVH	0,015	17	26	7	0,3	–	–	20	10,9
3803-B-2Z-TVH	0,015	17	26	7	0,3	–	–	20	10,9
3803-B-2RSR-TVH	0,015	17	26	7	0,3	–	–	20	10,9
3003-B-TVH	0,042	17	35	14	0,3	–	–	21,6	15,5
3003-B-2Z-TVH	0,042	17	35	14	0,3	–	–	21,6	15,5
3003-B-2RSR-TVH	0,042	17	35	14	0,3	–	–	21,6	15,5
3203-B-TVH	0,093	17	40	17,5	0,6	33,1	–	24	20
3203-B-2Z-TVH	0,095	17	40	17,5	0,6	–	35,1	24	20
3203-B-2RSR-TVH	0,095	17	40	17,5	0,6	–	35,1	24	20
3303-B-TVH	0,177	17	47	22,2	1	37,7	–	26,2	24
3804-B-TVH	0,02	20	32	10	0,3	–	–	24,3	14,3
3804-B-2Z-TVH	0,02	20	32	10	0,3	–	–	24,3	14,3
3804-B-2RSR-TVH	0,02	20	32	10	0,3	–	–	24,3	14,3
3004-B-TVH	0,08	20	42	16	0,6	–	–	25,2	19,1
3004-B-2Z-TVH	0,08	20	42	16	0,6	–	–	25,2	19,1
3004-B-2RSR-TVH	0,08	20	42	16	0,6	–	–	25,2	19,1
3204-B-TVH	0,154	20	47	20,6	1	38,7	–	28,9	24
3204-B-2Z-TVH	0,16	20	47	20,6	1	–	41,1	28,9	24
3204-B-2RSR-TVH	0,158	20	47	20,6	1	–	41,1	28,9	24
3304-B-TVH	0,217	20	52	22,2	1,1	42,7	–	31,2	26
3304-B-2Z-TVH	0,222	20	52	22,2	1,1	–	44,3	31,2	26
3304-B-2RSR-TVH	0,221	20	52	22,2	1,1	–	44,3	31,2	26

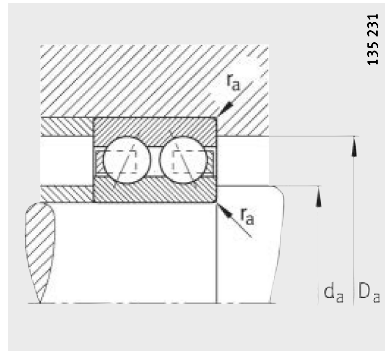
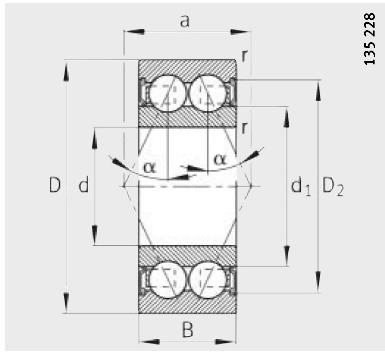

38..-B-2RSR, 30..-B-2RSR,
32..-B-2RSR, 33..-B-2RSR
 $\alpha = 25^\circ$

Mounting dimensions



Mounting dimensions			Basic load ratings		Fatigue limit load	Limiting speed	Reference speed
d_a	D_a	r_a	dyn. C_r	stat. C_{or}	C_{ur}	n_G	n_B
min.	max.	max.	N	N	N	min^{-1}	min^{-1}
17	22	0,3	2 430	1 960	99	22 000	14 800
17	22	0,3	2 430	1 960	99	16 000	14 800
17	22	0,3	2 430	1 960	99	14 000	–
17	30	0,3	8 600	5 400	275	20 000	15 800
17	30	0,3	8 600	5 400	275	15 000	15 800
17	30	0,3	8 600	5 400	275	12 000	–
19,2	30,8	0,6	11 800	7 100	360	19 000	17 100
19,2	30,8	0,6	11 800	7 100	360	14 000	17 100
19,2	30,8	0,6	11 800	7 100	360	12 000	–
20,6	36,4	1	16 300	10 000	460	16 000	11 000
19	24	0,3	2 480	2 080	107	19 000	13 200
19	24	0,3	2 480	2 080	107	14 000	13 200
19	24	0,3	2 480	2 080	107	12 000	–
19	33	0,3	9 200	6 200	315	18 000	15 400
19	33	0,3	9 200	6 200	315	13 000	15 400
19	33	0,3	9 200	6 200	315	11 000	–
21,2	35,8	0,6	14 600	9 000	420	17 000	15 500
21,2	35,8	0,6	14 600	9 000	420	12 000	15 500
21,2	35,8	0,6	14 600	9 000	420	10 000	–
22,6	41,4	1	20 800	12 500	570	15 000	11 500
22	30	0,3	5 800	4 850	245	17 000	11 900
22	30	0,3	5 800	4 850	245	12 000	11 900
22	30	0,3	5 800	4 850	245	10 000	–
23,2	38,8	0,6	14 500	9 600	485	16 000	13 300
23,2	38,8	0,6	14 500	9 600	485	11 000	13 300
23,2	38,8	0,6	14 500	9 600	485	9 000	–
25,6	41,4	1	19 600	12 500	610	15 000	13 600
25,6	41,4	1	19 600	12 500	610	10 000	13 600
25,6	41,4	1	19 600	12 500	610	8 500	–
27	45	1	23 200	15 000	690	13 000	9 500
27	45	1	23 200	15 000	690	9 000	9 500
27	45	1	23 200	15 000	690	8 000	–

Angular contact ball bearings

Double row
Open or sealed
Split inner ring

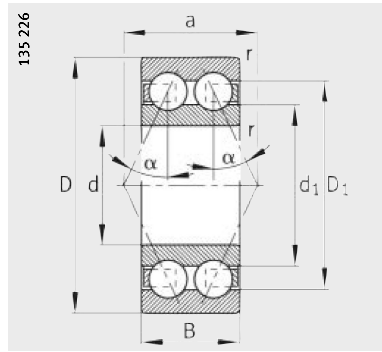

38..-B, 30..-B, 32..-B, 33..-B
 $\alpha = 25^\circ$

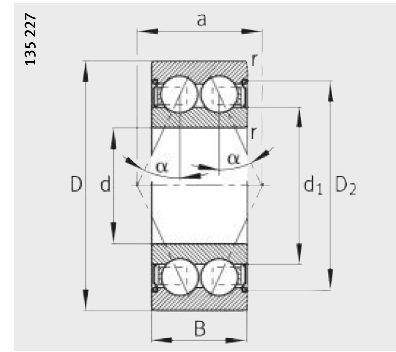

38..-B-2Z, 30..-B-2Z,
32..-B-2Z, 33..-B-2Z
 $\alpha = 25^\circ$

Dimension table (continued) · Dimensions in mm

Designation	Mass m ≈kg	Dimensions							
		d	D	B	r	D ₁	D ₂	d ₁	a
					min.	≈	≈	≈	≈
3805-B-TVH	0,025	25	37	10	0,3	–	–	28,3	15,9
3805-B-2Z-TVH	0,025	25	37	10	0,3	–	–	28,3	15,9
3805-B-2RSR-TVH	0,025	25	37	10	0,3	–	–	28,3	15,9
3005-B-TVH	0,1	25	47	16	0,6	–	–	29,8	21,2
3005-B-2Z-TVH	0,1	25	47	16	0,6	–	–	29,8	21,2
3005-B-2RSR-TVH	0,1	25	47	16	0,6	–	–	29,8	21,2
3205-B-TVH	0,178	25	52	20,6	1	43,7	–	33,9	26
3205-B-2Z-TVH	0,182	25	52	20,6	1	–	46,1	33,9	26
3205-B-2RSR-TVH	0,182	25	52	20,6	1	–	46,1	33,9	26
3305-B-TVH	0,353	25	62	25,4	1,1	50	–	37,2	31
3305-B-2Z-TVH	0,359	25	62	25,4	1,1	–	53,1	37,2	31
3305-B-2RSR-TVH	0,359	25	62	25,4	1,1	–	53,1	37,2	31
3305-DA-TVP	0,341	25	62	25,4	1,1	51,8	–	47,5	56
3806-B-TVH	0,03	30	42	10	0,3	–	–	32,8	18,1
3806-B-2Z-TVH	0,03	30	42	10	0,3	–	–	32,8	18,1
3806-B-2RSR-TVH	0,03	30	42	10	0,3	–	–	32,8	18,1
3006-B-TVH	0,16	30	55	19	1	–	–	35,6	24,8
3006-B-2Z-TVH	0,16	30	55	19	1	–	–	35,6	24,8
3006-B-2RSR-TVH	0,16	30	55	19	1	–	–	35,6	24,8
3206-B-TVH	0,289	30	62	23,8	1	52,1	–	40	31
3206-B-2Z-TVH	0,295	30	62	23,8	1	–	55,7	40	31
3206-B-2RSR-TVH	0,296	30	62	23,8	1	–	55,7	40	31
3306-B-TVH	0,548	30	72	30,2	1,1	58,9	–	44	36
3306-B-2Z-TVH	0,558	30	72	30,2	1,1	–	62,5	44	36
3306-B-2RSR-TVH	0,558	30	72	30,2	1,1	–	62,5	44	36
3306-DA	0,657	30	72	30,2	1,1	61,5	–	55,2	67

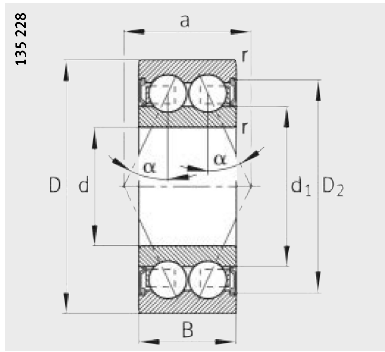

38..-B-2RSR, 30..-B-2RSR,
32..-B-2RSR, 33..-B-2RSR
 $\alpha = 25^\circ$

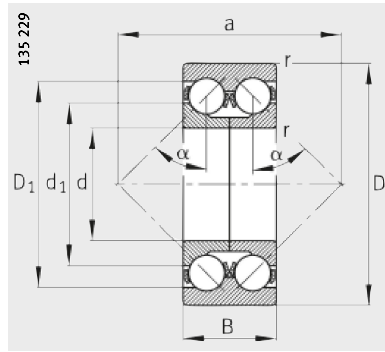

33..-DA
Split inner ring
 $\alpha = 45^\circ$

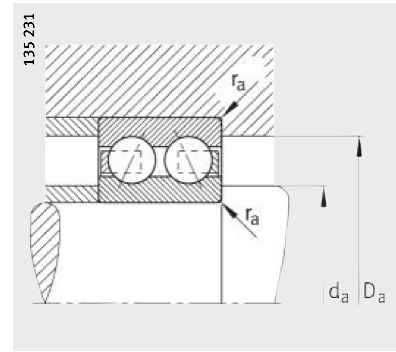

Mounting dimensions

Mounting dimensions			Basic load ratings		Fatigue limit load	Limiting speed	Reference speed
d_a	D_a	r_a	dyn. C_r	stat. C_{0r}	C_{ur}	n_G	n_B
min.	max.	max.	N	N	N	min^{-1}	min^{-1}
27	35	0,3	6 000	5 600	280	14 000	10 300
27	35	0,3	6 000	5 600	280	9 500	10 300
27	35	0,3	6 000	5 600	280	8 500	–
28,2	43,8	0,6	15 500	11 100	560	13 000	11 200
28,2	43,8	0,6	15 500	11 100	560	9 000	11 200
28,2	43,8	0,6	15 500	11 100	560	8 000	–
30,6	46,4	1	21 200	14 600	710	12 000	11 600
30,6	46,4	1	21 200	14 600	710	8 500	11 600
30,6	46,4	1	21 200	14 600	710	7 500	–
32	55	1	30 000	20 000	900	10 000	8 600
32	55	1	30 000	20 000	900	7 500	8 600
32	55	1	30 000	20 000	900	6 700	–
32	55	1	30 000	23 200	1 270	10 000	8 400
32	40	0,3	6 300	6 100	320	11 000	8 700
32	40	0,3	6 300	6 100	320	8 000	8 700
32	40	0,3	6 300	6 100	320	7 000	–
34,6	50,4	1	20 300	15 600	790	10 000	10 200
34,6	50,4	1	20 300	15 600	790	7 500	10 200
34,6	50,4	1	20 300	15 600	790	6 700	–
35,6	56,4	1	30 000	21 200	980	9 500	10 400
35,6	56,4	1	30 000	21 200	980	7 000	10 400
35,6	56,4	1	30 000	21 200	980	6 300	–
37	65	1	41 500	28 500	1 310	8 500	7 800
37	65	1	41 500	28 500	1 310	6 300	7 800
37	65	1	41 500	28 500	1 310	5 600	–
37	65	1	41 500	34 500	2 070	8 500	7 500

Angular contact ball bearings

Double row
Open or sealed
Split inner ring

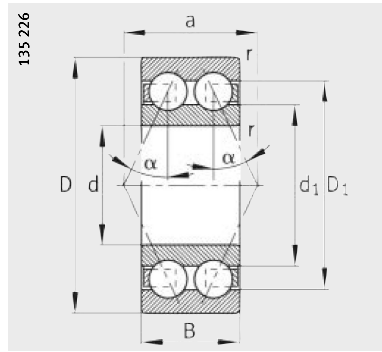

38..-B, 30..-B, 32..-B, 33..-B
 $\alpha = 25^\circ$

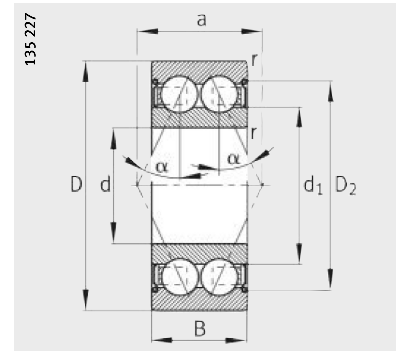

38..-B-2Z, 30..-B-2Z,
32..-B-2Z, 33..-B-2Z
 $\alpha = 25^\circ$

Dimension table (continued) · Dimensions in mm

Designation	Mass m ≈kg	Dimensions							
		d	D	B	r	D ₁	D ₂	d ₁	a
					min.	≈	≈	≈	≈
3807-B-TVH	0,035	35	47	10	0,3	–	–	38,5	20
3807-B-2Z-TVH	0,035	35	47	10	0,3	–	–	38,5	20
3807-B-2RSR-TVH	0,035	35	47	10	0,3	–	–	38,5	20
3007-B-TVH	0,2	35	62	20	1	–	–	41,7	27,8
3007-B-2Z-TVH	0,2	35	62	20	1	–	–	41,7	27,8
3007-B-2RSR-TVH	0,2	35	62	20	1	–	–	41,7	27,8
3207-B-TVH	0,446	35	72	27	1,1	60,6	–	47,2	36
3207-B-2Z-TVH	0,454	35	72	27	1,1	–	64,2	47,2	36
3207-B-2RSR-TVH	0,454	35	72	27	1,1	–	64,2	47,2	36
3307-B-TVH	0,657	35	80	34,9	1,5	65,5	–	49,3	41
3307-B-2Z-TVH	0,667	35	80	34,9	1,5	–	68,5	49,3	41
3307-B-2RSR-TVH	0,739	35	80	34,9	1,5	–	68,5	49,3	41
3307-DA	0,889	35	80	34,9	1,5	69,6	–	62	75
3808-B-TVH	0,04	40	52	10	0,3	–	–	43,4	22,4
3808-B-2Z-TVH	0,04	40	52	10	0,3	–	–	43,4	22,4
3808-B-2RSR-TVH	0,04	40	52	10	0,3	–	–	43,4	22,4
3008-B-TVH	0,25	40	68	21	1	–	–	46,7	30,8
3008-B-2Z-TVH	0,25	40	68	21	1	–	–	46,7	30,8
3008-B-2RSR-TVH	0,25	40	68	21	1	–	–	46,7	30,8
3208-B-TVH	0,594	40	80	30,2	1,1	67,9	–	53	41
3208-B-2Z-TVH	0,604	40	80	30,2	1,1	–	71,3	53	41
3208-B-2RSR-TVH	0,605	40	80	30,2	1,1	–	71,3	53	41
3308-B-TVH	0,984	40	90	36,5	1,5	74,6	–	55,6	46
3308-B-2Z-TVH	0,998	40	90	36,5	1,5	–	77,4	55,6	46
3308-B-2RSR-TVH	0,998	40	90	36,5	1,5	–	77,4	55,6	46
3308-DA-MA	1,19	40	90	36,5	1,5	79,4	–	72,5	85

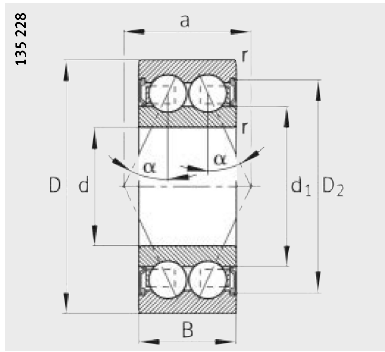

38..-B-2RSR, 30..-B-2RSR,
32..-B-2RSR, 33..-B-2RSR
 $\alpha = 25^\circ$

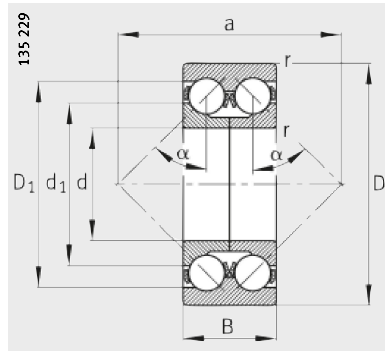

33..-DA
Split inner ring
 $\alpha = 45^\circ$

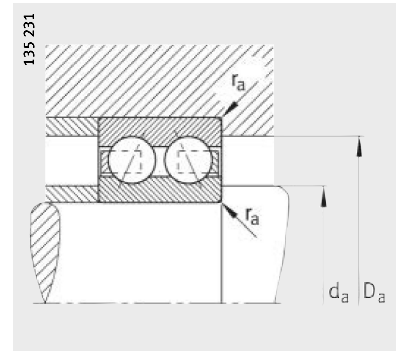

Mounting dimensions

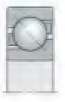

Mounting dimensions			Basic load ratings		Fatigue limit load C_{ur} N	Limiting speed n_G min^{-1}	Reference speed n_B min^{-1}
d_a min.	D_a max.	r_a max.	dyn. C_r N	stat. C_{or} N			
37	45	0,3	6 700	7 000	370	9 500	7 400
37	45	0,3	6 700	7 000	370	7 000	7 400
37	45	0,3	6 700	7 000	370	6 000	–
39,6	57,4	1	24 500	19 400	980	9 000	8 800
39,6	57,4	1	24 500	19 400	980	6 700	8 800
39,6	57,4	1	24 500	19 400	980	5 600	–
42	65	1	39 000	28 500	1 370	8 500	9 200
42	65	1	39 000	28 500	1 370	6 300	9 200
42	65	1	39 000	28 500	1 370	5 300	–
44	71	1,5	51 000	34 500	1 650	7 500	7 400
44	71	1,5	51 000	34 500	1 650	5 600	7 400
44	71	1,5	51 000	34 500	1 650	5 000	–
44	71	1,5	50 000	41 500	2 480	7 500	7 100
42	50	0,3	7 000	7 800	425	8 500	6 400
42	50	0,3	7 000	7 800	425	6 300	6 400
42	50	0,3	7 000	7 800	425	5 300	–
44,6	63,4	1	25 500	21 700	1 100	8 000	8 000
44,6	63,4	1	25 500	21 700	1 100	6 000	8 000
44,6	63,4	1	25 500	21 700	1 100	5 000	–
47	73	1	48 000	36 500	1 840	7 500	8 500
47	73	1	48 000	36 500	1 840	5 600	8 500
47	73	1	48 000	36 500	1 840	4 800	–
49	81	1,5	62 000	45 000	2 500	6 700	6 400
49	81	1,5	62 000	45 000	2 500	5 000	6 400
49	81	1,5	62 000	45 000	2 500	4 500	–
49	81	1,5	62 000	53 000	3 150	6 300	6 000

Angular contact ball bearings

Double row
Open or sealed
Split inner ring

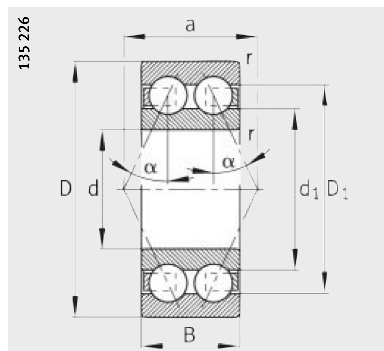

38..-B, 32..-B, 33..-B
 $\alpha = 25^\circ$

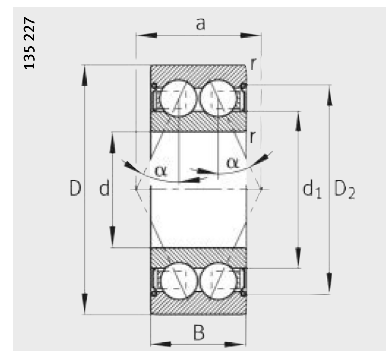

38..-B-2Z, 32..-B-2Z, 33..-B-2Z
 $\alpha = 25^\circ$

Dimension table (continued) · Dimensions in mm

Designation	Mass m ≈kg	Dimensions							
		d	D	B	r	D ₁	D ₂	d ₁	a
					min.	≈	≈	≈	≈
3809-B-TVH	0,053	45	58	10	0,3	–	–	48,6	24,2
3809-B-2Z-TVH	0,053	45	58	10	0,3	–	–	48,6	24,2
3809-B-2RSR-TVH	0,053	45	58	10	0,3	–	–	48,6	24,2
3209-B-TVH	0,628	45	85	30,2	1,1	72,9	–	57,2	43
3209-B-2Z-TVH	0,64	45	85	30,2	1,1	–	75,5	57,2	43
3209-B-2RSR-TVH	0,64	45	85	30,2	1,1	–	75,5	57,2	43
3309-B-TVH	1,34	45	100	39,7	1,5	81,5	–	62,3	50
3309-B-2Z-TVH	1,36	45	100	39,7	1,5	–	86,5	62	50
3309-B-2RSR-TVH	1,36	45	100	39,7	1,5	–	86,5	62	50
3309-DA	1,55	45	100	39,7	1,5	86,7	–	78,6	93
3810-B-TVH	0,07	50	65	12	0,3	–	–	55,1	27,1
3810-B-2Z-TVH	0,07	50	65	12	0,3	–	–	55,1	27,1
3810-B-2RSR-TVH	0,07	50	65	12	0,3	–	–	55,1	27,1
3210-B-TVH	0,68	50	90	30,2	1,1	77,9	–	62	45
3210-B-2Z-TVH	0,692	50	90	30,2	1,1	–	80,9	62	45
3210-B-2RSR-TVH	0,693	50	90	30,2	1,1	–	80,9	62	45
3310-B-TVH	1,8	50	110	44,4	2	89,5	–	68,3	55
3310-B-2Z-TVH	1,82	50	110	44,4	2	–	96	64	55
3310-B-2RSR-TVH	1,82	50	110	44,4	2	–	96	64	55
3310-DA-MA	2,24	50	110	44,4	2	96,9	–	87,6	104
3811-B-TVH	0,09	55	72	13	0,3	–	–	61,9	30,7
3811-B-2Z-TVH	0,09	55	72	13	0,3	–	–	61,9	30,7
3811-B-2RSR-TVH	0,09	55	72	13	0,3	–	–	61,9	30,7
3211-B-TVH	0,954	55	100	33,3	1,5	85,3	–	69	50
3211-B-2Z-TVH	0,969	55	100	33,3	1,5	–	89,1	68,7	50
3211-B-2RSR-TVH	0,969	55	100	33,3	1,5	–	89,1	68,7	50
3311-B-TVH	2,32	55	120	49,2	2	98,4	–	75,2	61
3311-B-2Z-TVH	2,36	55	120	49,2	2	–	105,2	75,2	61
3311-B-2RSR-TVH	2,35	55	120	49,2	2	–	105,2	75,2	61
3311-DA-MA	2,85	55	120	49,2	2	105,3	–	94,6	111

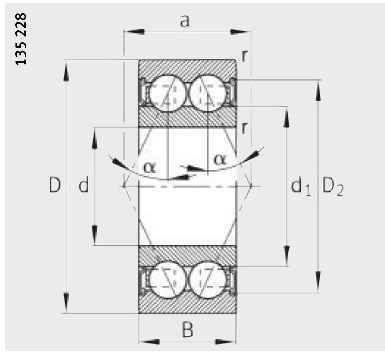

38..-B-2RSR, 32..-B-2RSR,
33..-B-2RSR
 $\alpha = 25^\circ$

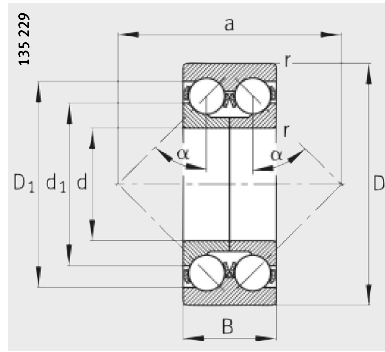

33..-DA
Split inner ring
 $\alpha = 45^\circ$

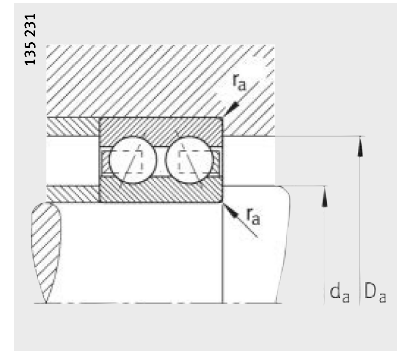

Mounting dimensions

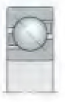

Mounting dimensions			Basic load ratings		Fatigue limit load	Limiting speed	Reference speed
d_a	D_a	r_a	dyn. C_r	stat. C_{0r}	C_{ur}	n_G	n_B
min.	max.	max.	N	N	N	min^{-1}	min^{-1}
47	56	0,3	7 200	8 300	465	7 500	5 700
47	56	0,3	7 200	8 300	465	5 600	5 700
47	56	0,3	7 200	8 300	465	5 000	–
52	78	1	48 000	37 500	1 800	6 700	7 800
52	78	1	48 000	37 500	1 800	5 000	7 800
52	78	1	48 000	37 500	1 800	4 500	–
54	91	1,5	68 000	51 000	2 750	6 000	6 100
54	91	1,5	68 000	51 000	2 750	4 500	6 100
54	91	1,5	68 000	51 000	2 750	4 000	–
54	91	1,5	75 000	64 000	3 400	6 000	5 800
52	63	0,3	8 700	10 400	580	7 000	5 400
52	63	0,3	8 700	10 400	580	5 300	5 400
52	63	0,3	8 700	10 400	580	4 500	–
57	83	1	51 000	42 500	2 120	6 300	7 100
57	83	1	51 000	42 500	2 120	4 800	7 100
57	83	1	51 000	42 500	2 120	4 000	–
61	99	2	81 500	62 000	3 450	5 300	5 800
61	99	2	81 500	62 000	3 450	4 000	5 800
61	99	2	81 500	62 000	3 450	3 600	–
61	99	2	90 000	85 000	5 200	5 300	5 300
57	70	0,3	12 100	15 700	880	6 300	5 100
57	70	0,3	12 100	15 700	880	4 500	5 100
57	70	0,3	12 100	15 700	880	4 300	–
64	91	1,5	58 500	49 000	2 390	5 600	6 800
64	91	1,5	58 500	49 000	2 390	4 300	6 800
64	91	1,5	58 500	49 000	2 390	3 800	–
66	109	2	102 000	78 000	4 250	5 000	5 400
66	109	2	102 000	78 000	4 250	3 800	5 400
66	109	2	102 000	78 000	4 250	3 400	–
66	109	2	110 000	100 000	5 400	5 000	5 200

Angular contact ball bearings

Double row
Open or sealed
Split inner ring

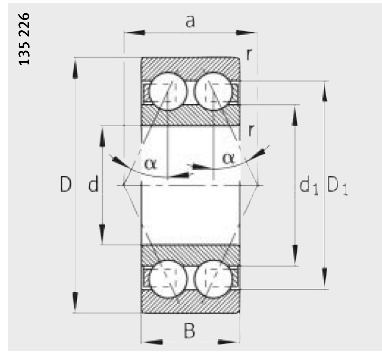

38..-B, 32..-B, 33..-B
 $\alpha = 25^\circ$

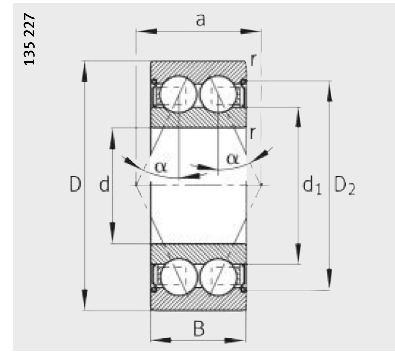

38..-B-2Z, 32..-B-2Z
 $\alpha = 25^\circ$

Dimension table (continued) · Dimensions in mm

Designation	Mass m ≈kg	Dimensions							
		d	D	B	r	D ₁	D ₂	d ₁	a
					min.	≈	≈	≈	≈
3812-B-TVH	0,14	60	78	14	0,3	–	–	65,9	33,2
3812-B-2Z-TVH	0,14	60	78	14	0,3	–	–	65,9	33,2
3812-B-2RSR-TVH	0,14	60	78	14	0,3	–	–	65,9	33,2
3212-B-TVH	1,27	60	110	36,5	1,5	94,5	–	75,8	55
3212-B-2Z-TVH	1,29	60	110	36,5	1,5	–	98,6	75,8	55
3212-B-2RSR-TVH	1,29	60	110	36,5	1,5	–	98,6	75,8	55
3312-B-TVH	2,92	60	130	54	2,1	108,7	–	81,6	67
3312-B-2RSR-TVH	2,92	60	130	54	2,1	–	113,1	81,6	67
3312-DA	3,39	60	130	54	2,1	115,8	–	101,7	122
3813-B-TVH	0,16	65	85	15	0,6	–	–	71,2	36,2
3813-B-2Z-TVH	0,16	65	85	15	0,6	–	–	71,2	36,2
3813-B-2RSR-TVH	0,16	65	85	15	0,6	–	–	71,2	36,2
3213-B-TVH	1,64	65	120	38,1	1,5	103,9	–	84,8	60
3213-B-2RSR-TVH	1,66	65	120	38,1	1,5	–	107,2	84,5	60
3313-B-TVH	3,63	65	140	58,7	2,1	117,6	–	88,6	71
3313-DA	4,38	65	140	58,7	2,1	124,3	–	110,2	131
3814-B-TVH	0,19	70	90	15	0,6	–	–	76,5	38,5
3814-B-2Z-TVH	0,19	70	90	15	0,6	–	–	76,5	38,5
3814-B-2RSR-TVH	0,19	70	90	15	0,6	–	–	76,5	38,5
3214-B-TVH	1,8	70	125	39,7	1,5	106,3	–	87	62
3214-B-2RSR-TVH	1,83	70	125	39,7	1,5	–	111,6	86,8	62
3314	5,03	70	150	63,5	2,1	131,9	–	98,5	109
3314-DA	5,36	70	150	63,5	2,1	132,4	–	118,2	141
3815-B-TVH	0,21	75	95	15	0,6	–	–	81,2	40,4
3815-B-2Z-TVH	0,21	75	95	15	0,6	–	–	81,2	40,4
3815-B-2RSR-TVH	0,21	75	95	15	0,6	–	–	81,2	40,4
3215-B-TVH	1,91	75	130	41,3	1,5	112,6	–	92,4	65
3215-B-2RSR-TVH	1,94	75	130	41,3	1,5	–	116,4	92,1	65
3315	6,07	75	160	68,3	2,1	141,2	–	105,5	117

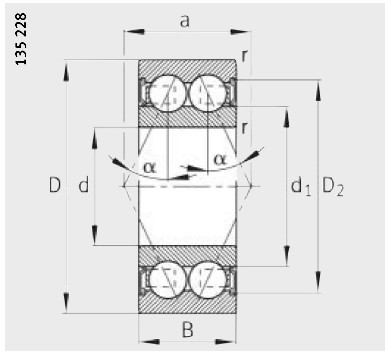

38..-B-2RSR, 32..-B-2RSR,
33..-B-2RSR
 $\alpha = 25^\circ$

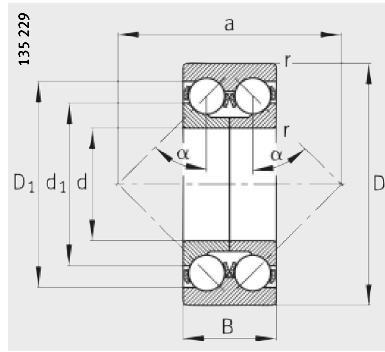

33..-DA
Split inner ring
 $\alpha = 45^\circ$

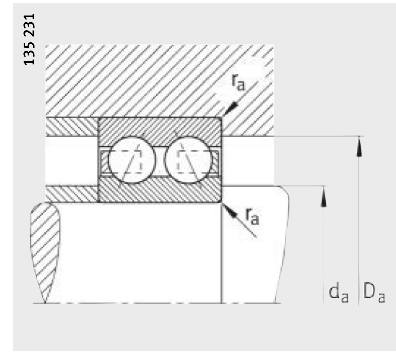

Mounting dimensions

Mounting dimensions			Basic load ratings		Fatigue limit load C_{ur} N	Limiting speed n_G min^{-1}	Reference speed n_B min^{-1}
d_a min.	D_a max.	r_a max.	dyn. C_r N	stat. C_{or} N			
62	76	0,3	14 500	17 500	960	5 600	4 700
62	76	0,3	14 500	17 500	960	4 300	4 700
62	76	0,3	14 500	17 500	960	3 800	–
69	101	1,5	72 000	61 000	3 450	5 000	6 200
69	101	1,5	72 000	61 000	3 450	3 800	6 200
69	101	1,5	72 000	61 000	3 450	3 400	–
72	118	2,1	125 000	98 000	5 400	4 500	5 100
72	118	2,1	125 000	98 000	5 400	3 000	–
72	118	2,1	127 000	118 000	6 500	4 500	4 850
68,2	81,8	0,6	17 700	21 400	1 120	5 000	4 500
68,2	81,8	0,6	17 700	21 400	1 120	4 000	4 500
68,2	81,8	0,6	17 700	21 400	1 120	3 600	–
74	111	1,5	80 000	73 500	3 700	4 500	5 600
74	111	1,5	80 000	73 500	3 700	3 000	–
77	128	2,1	143 000	112 000	6 100	4 300	4 850
77	128	2,1	143 000	137 000	7 200	4 300	4 650
73,2	86,8	0,6	19 200	23 800	1 300	5 000	4 100
73,2	86,8	0,6	19 200	23 800	1 300	3 800	4 100
73,2	86,8	0,6	19 200	23 800	1 300	3 400	–
79	116	1,5	83 000	76 500	4 000	4 500	5 600
79	116	1,5	83 000	76 500	4 000	3 400	–
82	138	2,1	143 000	166 000	8 500	4 000	4 500
82	138	2,1	163 000	156 000	8 200	4 000	4 550
78,2	91,8	0,6	19 400	24 400	1 370	4 800	3 950
78,2	91,8	0,6	19 400	24 400	1 370	3 600	3 950
78,2	91,8	0,6	19 400	24 400	1 370	3 200	–
84	121	1,5	91 500	85 000	4 250	4 300	5 300
84	121	1,5	91 500	85 000	4 250	2 800	–
87	148	2,1	163 000	193 000	9 700	3 800	4 350

Angular contact ball bearings

Double row
Open or sealed

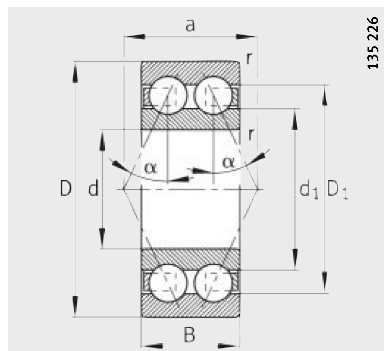

38..-B, 32..-B
 $\alpha = 25^\circ$

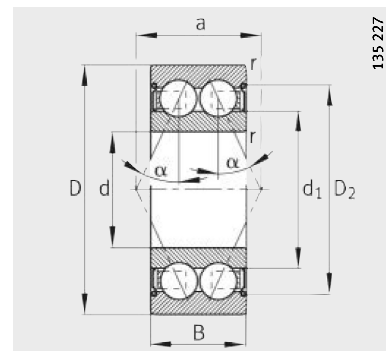

38..-B-2Z, 32..-B-2Z
 $\alpha = 25^\circ$

Dimension table (continued) · Dimensions in mm

Designation	Mass m ≈kg	Dimensions							
		d	D	B	r	D ₁	D ₂	d ₁	a
3816-B-TVH	0,23	80	100	15	0,6	–	–	85,5	42,2
3816-B-2Z-TVH	0,23	80	100	15	0,6	–	–	85,5	42,2
3816-B-2RSR-TVH	0,23	80	100	15	0,6	–	–	85,5	42,2
3216-B-TVH	2,45	80	140	44,4	2	120,3	–	98,5	69
3216-B-2Z-TVH	2,48	80	140	44,4	2	–	125,4	98,5	69
3316	7,26	80	170	68,3	2,1	149,7	–	111,8	123
3217	3,44	85	150	49,2	2	135,1	–	108,5	106
3317-M	8,78	85	180	73	3	160	–	119,6	131
3218	4,22	90	160	52,4	2	143,7	–	115,6	113
3318	9,23	90	190	73	3	168,2	–	126,1	136
3219-M	5,31	95	170	55,6	2,1	152,8	–	122,2	120
3319-M	11,4	95	200	77,8	3	177,3	–	133	143
3220	6,19	100	180	60,3	2,1	163,7	–	131	127
3320-M	14,6	100	215	82,6	3	188,7	–	142,5	153
3221-M	7,78	105	190	65,1	2,1	172,9	–	138	135
3222-M	9,23	110	200	69,8	2,1	180,1	–	143,3	144
3322-M	20	110	240	92,1	3	209,6	–	161,5	171