

BEARINGS

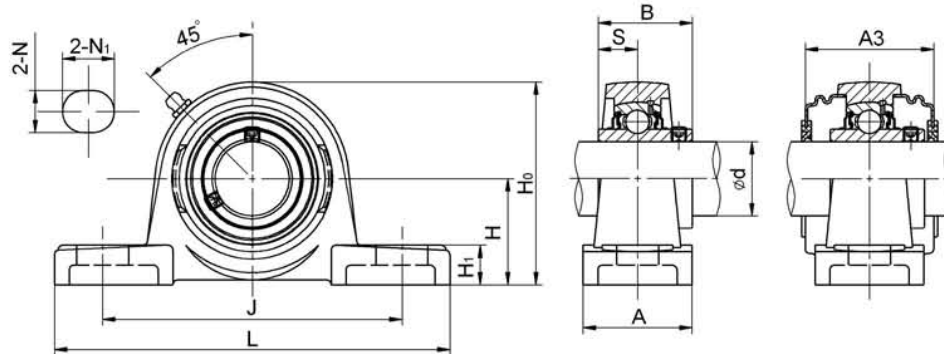

UCP200 Series

Unit No.	Shaft Dia		Dimensions(mm)										Bolt Size (mm)	Weight (kg)	
	d (in)	d (mm)	H	L	J	A	N	N ₁	H ₁	H ₀	B	S			A3
UCWP201 202 203		12 15 17	30.2	125	95	32	13	18	13	57	27.4	11.5		M10	0.72 0.66 0.66
UCP201 201-8	1/2	12	30.2	127	95	38	13	19	14	61	31	12.7		M10	0.76
UCP202 202-9 202-10	9/16 5/8	15	30.2	127	95	38	13	19	14	61	31	12.7		M10	0.74
UCP203 203-11	11/16	17	30.2	127	95	38	13	19	14	61	31	12.7		M10	0.72
UCP204 204-12	3/4	20	33.3	127	95	38	13	19	14	64	31	12.7	46.4	M10	0.70
UCP205 205-14 205-15 205-16	7/8 15/16 1	25	36.5	140	105	38	13	19	15	71	34.1	14.3	48	M10	0.76
UCP206 206-17 206-18 206-19 206-20	1-1/16 1-1/8 1-3/16 1-1/4	30	42.9	160	121	42	17	20	16	84	38.1	15.9	52	M14	1.25
UCP207 207-20 207-21 207-22 207-23	1-1/4 1-5/16 1-3/8 1-7/16	35	47.6	167	126	48	17	20	17	92	42.9	17.5	59	M14	1.55
UCP208 208-24 208-25	1-1/2 1-9/16	40	49.2	181	137	53	17	20	18	99	49.2	19	68.2	M14	1.90
UCP209 209-26 209-27 209-28	1-5/8 1-11/16 1-3/4	45	54	190	146	54	17	20	20	106	49.2	19	70	M14	2.20
UCP210 210-30 210-31 210-32	1-7/8 1-15/16 2	50	57.2	206	159	60	20	23	21	114	51.6	19	76	M16	2.75
UCP211 211-32 211-34 211-35	2 2-1/8 2-3/16	55	63.5	220	172	60	20	23	23	125	55.6	22.2	76	M16	3.30
UCP212 212-36 212-38 212-39	2-1/4 2-3/8 2-7/16	60	69.9	241	186	70	20	23	25	137	65.1	25.4	89	M16	4.70
UCP213 213-40	2-1/2	65	76.2	262	203	70	25	28	26	149	65.1	25.4	89	M20	5.60
UCP214 214-44	2-3/4	70	79.4	266	210	72	25	28	28	157	74.6	30.2	98	M20	6.60
UCP215 215-47 215-48	2-15/16 3	75	82.6	272	217	72	25	28	28	159	77.8	33.3	97	M20	7.30
UCP216		80	88.9	292	232	80	25	30	30	174	82.6	33.3	110	M20	9.00
UCP217 217-52	3-1/4	85	95.2	310	247	82	25	28	32	185	85.7	34.1	114.2	M20	10.80
UCP218 218-56	3-1/2	90	101.6	324	262	87	27	30	33	197	96	39.7	124	M22	13.00
UCP220		100	115	380	305	95	30	36	40	225	108	42		M24	16.00

NOTE: 1 Grease fittings available at 90° and 45° positions.
2 Open / Close (S/SM) covers are optional

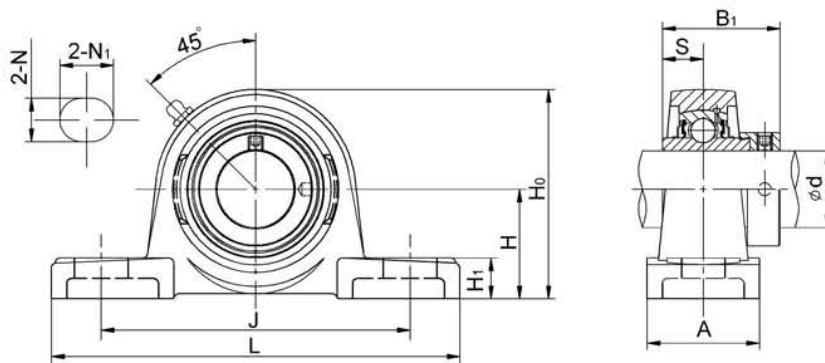

NAP200 Series

Unit No.	Shaft Dia		Dimensions (mm)										Bolt Size (mm)	Weight (kg)
	d (in)	d (mm)	H	L	J	A	N	N ₁	H ₁	H ₀	B ₁	S		
NAP 201 201-8	1/2	12	30.2	127	95	38	13	19	14	61	43.7	17.1	M10	0.72
202 202-9 202-10	9/16 5/8	15	30.2	127	95	38	13	19	14	61	43.7	17.1	M10	0.72
203 203-11	11/16	17	30.2	127	95	38	13	19	14	61	43.7	17.1	M10	0.72
NAP 204 204-12	3/4	20	33.3	127	95	38	13	19	14	64	43.7	17.1	M10	0.72
NAP 205 205-14 205-15 205-16	7/8 15/16 1	25	36.5	140	105	38	13	19	15	71	44.4	17.5	M10	0.8
NAP 206 206-18 206-19 206-20	1-1/16 1-1/8 1-3/16 1-1/4	30	42.9	160	121	42	17	20	16	84	48.4	18.3	M14	1.35
NAP 207 207-20 207-21 207-22 207-23	1-1/4 1-5/16 1-3/8 1-7/16	35	47.6	167	126	48	17	20	17	92	51.1	18.8	M14	1.7
NAP 208 208-24 208-25	1-1/2 1-9/16	40	49.2	181	137	53	17	20	18	99	56.3	21.4	M14	2
NAP 209 209-26 209-27 209-28	1-5/8 1-11/16 1-3/4	45	54	190	146	54	17	20	20	106	56.3	21.4	M14	2.42
NAP 210 210-30 210-31 210-32	1-7/8 1-15/16 2	50	57.2	206	159	60	20	23	21	114	62.7	24.6	M16	2.75
NAP 211 211-32 211-34 211-35	2 2-1/8 2-3/16	55	63.5	218	172	60	20	23	23	125	71.4	27.8	M16	3.56
NAP 212 212-36 212-38 212-39	2-1/4 2-3/8 2-7/16	60	69.9	241	186	70	20	23	25	137	77.8	31	M16	5.2
NAP 213 213-40	2-1/2	65	76.2	262	203	70	25	28	26	149	85.7	34.3	M20	6.3
NAP 214 214-44	2-3/4	70	79.4	266	210	72	25	28	28	157	85.7	34.3	M20	7
NAP 215 215-47 215-48	2-15/16 3	75	82.6	272	217	72	25	28	28	159	92.1	37.3	M20	7.8

NOTE: 1 Grease fittings available at 90° and 45° positions.

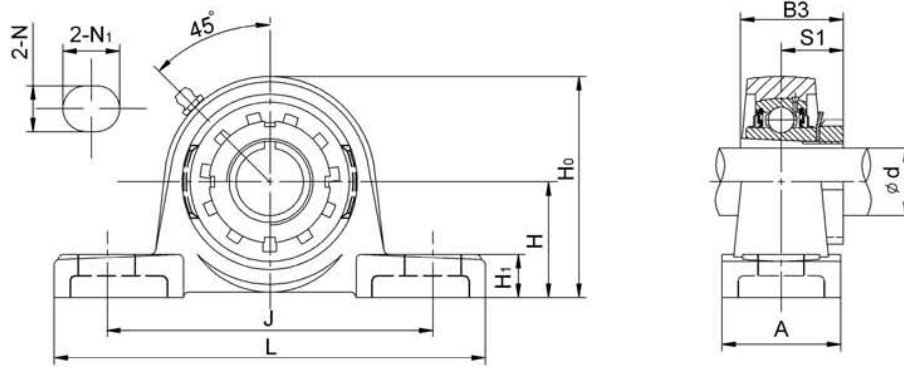

UKP200+H Series

Unit No.	Shaft Dia		Dimensions (mm)										Bolt Size (mm)	Weight (kg)
	d		H	L	J	A	N	N ₁	H ₁	H ₀	B ₃	S ₁		
	(in)	(mm)												
UKP205+H2305 205+HE2305	3/4	20	36.5	140	105	38	13	19	15	71	35	18.5	M10	0.83
UKP206+H2306 206+HS2306 206+HA2306 206+HE2306	7/8 15/16 1	25	42.9	160	121	42	17	20	16	84	38	20.5	M14	1.3
UKP207+H2307 207+HE2307 207+HS2307	1-1/8 1-3/16	30	47.6	167	126	48	17	20	17	92	43	22.5	M14	1.5
UKP208+H2308 208+HE2308 208+HS2308	1-1/4 1-3/8	35	49.2	181	137	53	17	20	18	99	46	24.5	M14	2.0
UKP209+H2309 209+HA2309 209+HE2309	1-7/16 1-1/2	40	54	190	146	54	17	20	20	106	50	26	M14	2.3
UKP210+H2310 210+HS2310 210+HA2310 210+HE2310	1-5/8 1-11/16 1-3/4	45	57.2	206	159	60	20	23	21	114	55	27.5	M16	3.0
UKP211+H2311 211+HS2311 211+HA2311 211+HE2311	1-7/8 1-15/16 2	50	63.5	218	172	60	20	23	23	125	59	28.5	M16	3.5
UKP212+H2312 212+HS2312	2-1/8	55	69.9	241	186	70	20	23	25	137	62	31	M16	4.7
UKP213+H2313 213+HA2313 213+HE2313 213+HS2313	2-3/16 2-1/4 2-3/8	60	76.2	262	203	70	25	28	26	149	65	32	M20	5.9
UKP215+H2315 215+HA2315 215+HE2315	2-7/16 2-1/2	65	82.6	272	217	72	25	28	28	159	73	35.5	M20	7.6
UKP216+H2316 216+HA2316 216+HE2316	2-11/16 2-3/4	70	88.9	292	232	80	25	30	30	174	78	39	M20	9.2
UKP217+H2317		75	95.2	310	247	84	25	28	32	185	82	40	M20	
UKP218+H2318		80	101.6	326	262	87	27	30	33	197	86	42	M22	

NOTE: 1 Grease fittings available at 90° and 45° positions.

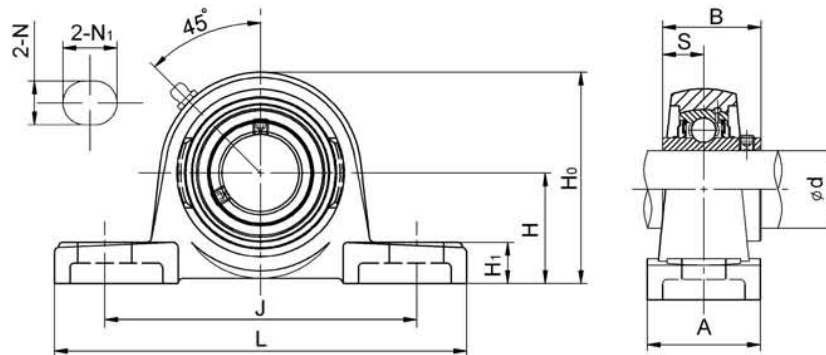

UCPX00 Series

Unit No.	Shaft Dia		Dimensions (mm)										Bolt Size (mm)	Weight (kg)	
	d		H	L	J	A	N	N ₁	H ₁	H ₀	B	S			
	(in)	(mm)													
UCPX05		25													
05-13	13/16														
05-14	7/8		44.4	159	119	51	17	20	18	85	38.1	15.9	M14	1.5	
05-15	15/16														
05-16	1														
UCPX06		30													
06-17	1-1/16														
06-18	1-1/8		47.6	175	127	57	17	20	20	93	42.9	17.5	M14	2.1	
06-19	1-3/16														
06-20	1-1/4														
UCPX07		35													
07-21	1-5/16														
07-22	1-3/8		54.0	203	144	57	17	20	21	105	49.2	19	M14	2.7	
07-23	1-7/16														
UCPX08		40													
08-24	1-1/2														
08-25	1-9/16		58.7	222	156	67	20	23	26	112	49.2	19	M16	3.3	
UCPX09		45													
09-26	1-5/8														
09-27	1-11/16		58.7	222	156	67	20	23	26	116	51.6	19	M16	3.3	
09-28	1-3/4														
09-29	1-13/16														
UCPX10		50													
10-30	1-7/8														
10-31	1-15/16		63.5	240	171	73	20	23	28	127	55.6	22.2	M16	4.3	
10-32	2														
UCPX11		55													
11-33	2-1/16														
11-34	2-1/8														
11-35	2-3/16		69.8	260	184	79	25	28	30	137	65.1	25.4	M20	5.7	
11-36	2-1/4														
11-37	2-5/16														
UCPX12		60													
12-38	2-3/8														
12-39	2-7/16		76.2	286	203	83	25	28	34	151	65.1	25.4	M20	7.3	
UCPX13		65													
13-40	2-1/2														
13-41	2-9/16		76.2	286	203	83	25	28	34	154	74.6	30.2	M20	7.6	
UCPX14		70													
14-42	2-5/8														
14-43	2-11/16		88.9	330	229	89	27	30	34	170	77.8	33.3	M22	9.9	
14-44	2-3/4														
UCPX15		75													
15-45	2-13/16														
15-46	2-7/8		88.9	330	229	89	27	30	35	176	82.6	33.3	M22	11	
15-47	2-15/16														
15-48	3														
UCPX16		80													
16-49	3-1/16														
16-50	3-1/8		101.6	378	283	102	27	30	40	194	85.7	34.1	M22	15	
16-51	3-3/16														
16-52	3-1/4														
UCPX17		85													
17-53	3-5/16														
17-55	3-7/16		101.6	384	283	102	27	30	40	202	96	39.7	M22	16	

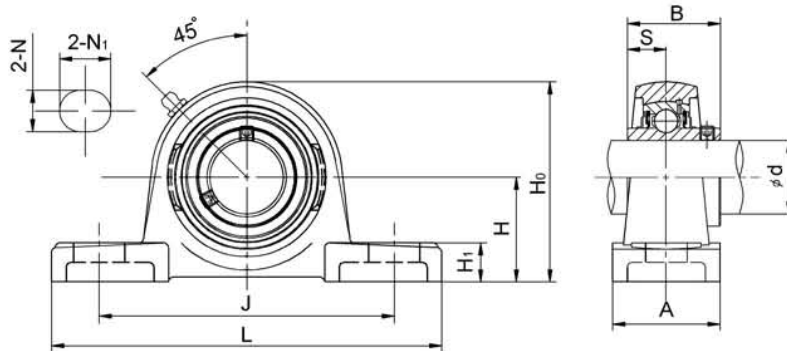

UCP300 Series

Unit No	Shaft d (mm)	Dimensions(mm)										Bolt size (mm)	Weight (kg)
		H	L	J	A	N	N ₁	H ₁	H ₀	B	S		
UCP305	25	45	175	132	45	17	20	16	85	38	15	M14	1.40
UCP306	30	50	180	140	50	17	20	18	95	43	17	M14	1.80
UCP307	35	56	210	160	56	17	25	20	106	48	19	M14	2.80
UCP308	40	60	220	170	60	17	25	24	116	52	19	M14	3.08
UCP309	45	67	245	190	67	20	30	25	129	57	22	M16	4.10
UCP310	50	75	275	212	75	20	35	27	143	61	22	M16	6.00
UCP311	55	80	310	236	80	20	38	30	154	66	25	M16	7.40
UCP312	60	85	330	250	85	25	38	32	165	71	26	M20	9.40
UCP313	65	90	340	260	90	25	38	33	178	75	30	M20	10.00
UCP314	70	95	360	280	90	27	40	35	187	78	33	M22	12.00
UCP315	75	100	377	290	100	27	40	35	198	82	32	M22	14.00
UCP316	80	106	398	300	110	27	40	40	210	86	34	M22	18.00
UCP317	85	112	420	320	110	33	45	40	222	96	40	M27	20.00
UCP318	90	118	430	330	110	33	46	45	235	96	40	M27	24.00
UCP319	95	125	470	360	120	36	50	46	250	103	41	M30	26.50
UCP320	100	140	490	380	120	36	50	50	275	108	42	M30	34.30
UCP321	105	140	490	380	120	36	50	50	280	112	44	M30	36.60
UCP322	110	150	520	400	140	40	55	55	300	117	46	M33	42.50
UCP324	120	160	570	450	140	40	55	65	320	126	51	M33	53.50
UCP326	130	180	600	480	140	40	55	75	355	135	54	M33	72.10
UCP328	140	200	620	500	140	40	55	75	390	145	59	M33	89.10

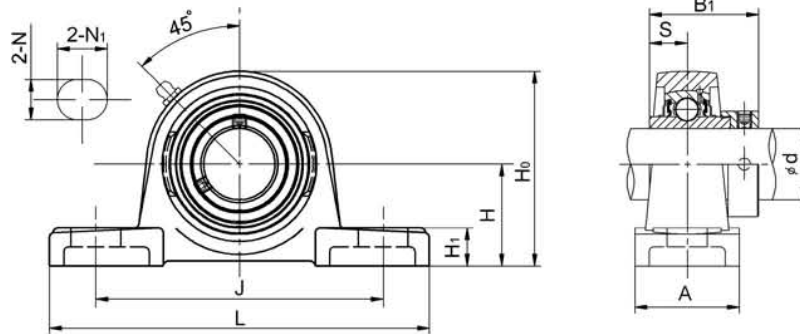

NAP300 Series

Unit No.	Shaft Dia		Dimensions (mm)										Bolt Size (mm)	Weight (kg)	
	d		H	L	J	A	N	N ₁	H ₁	H ₀	B ₁	S			
	(in)	(mm)													
NAP 305		25													
305-14	7/8		45	175	132	45	17	20	16	85	46.8	16.7	M14	1.4	
305-15	15/16														
305-16	1														
NAP 306		30													
306-18	1-1/8		50	180	140	50	17	20	18	95	50	17.5	M14	1.9	
306-19	1-3/16														
NAP 307		35													
307-20	1-1/4		56	210	160	56	17	25	20	106	51.6	18.3	M14	2.9	
307-21	1-5/16														
307-22	1-3/8														
NAP 308		40													
308-24	1-1/2		60	220	170	60	17	25	24	116	57.1	19.8	M14	3.1	
308-25	1-9/16														
NAP 309		45													
309-26	1-5/8		67	245	190	67	20	30	25	129	58.7	19.8	M16	4.3	
309-27	1-11/16														
309-28	1-3/4														
NAP 310		50													
310-30	1-7/8		75	275	212	75	20	35	27	143	66.6	24.6	M16	6.0	
310-31	1-15/16														
NAP 311		55													
311-32	2		80	310	236	80	20	38	30	154	73	27.8	M16	7.7	
311-34	2-1/8														
311-35	2-3/16														
NAP 312		60													
312-36	2-1/4		85	330	250	85	25	38	32	165	79.4	30.95	M20	9.7	
312-38	2-3/8														
312-39	2-7/16														
NAP 313		65													
313-40	2-1/2		90	340	260	90	25	38	33	178	85.2	32.55	M20	11	
NAP 314		70													
314-44	2-3/4		95	360	280	90	27	40	35	187	92.1	34.15	M22	12	
NAP 315		75													
315-48	3		100	377	290	100	27	40	35	198	100	37.3	M22	15	
NAP 316		80													
316-52	3-1/4		112	420	320	110	33	45	40	222	109.5	42.05	M27	21	
NAP 317		85													
317-52	3-1/4		112	420	320	110	33	45	40	222	109.5	42.05	M27	21	
NAP 318		90													
318-56	3-1/2		118	430	330	110	33	46	45	235	115.9	43.65	M27	25	
NAP 319		95													
319-60	3-3/4		125	470	360	120	36	50	46	250	122.3	38.9	M30	30	
NAP 320		100													
320-64	4		140	488	380	120	36	50	50	275	128.6	50	M30	37	

NOTE: 1 Grease fittings available at 90° and 45° positions.

BEARINGS

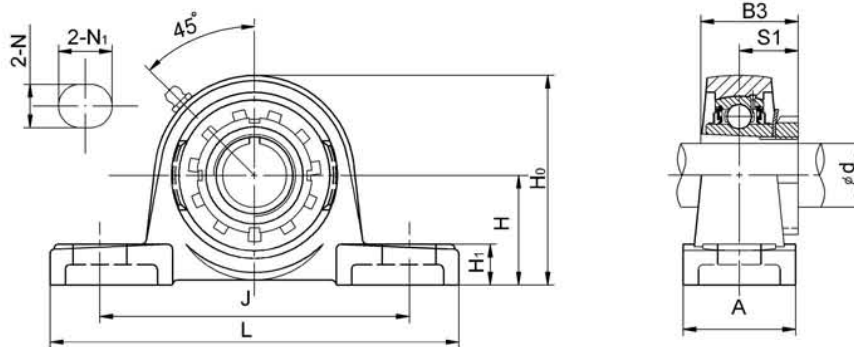

UKP300+H Series

Unit No.	Shaft Dia		Dimensions (mm)										Bolt Size (mm)	Weight (kg)
	d (in)	d (mm)	H	L	J	A	N	N ₁	H ₁	H ₀	B ₃	S ₁		
UKP305+H2305 305+HE2305	3/4	20	45	175	132	45	17	20	16	85	35	21.5	M14	1.4
UKP306+H2306 306+HS2306 306+HA2306 306+HE2306	7/8 15/16 1	25	50	180	140	50	17	20	18	95	38	23	M14	1.8
UKP307+H2307 307+HE2307 307+HS2307	1-1/8 1-3/16	30	56	210	160	56	17	25	20	106	43	25.5	M14	2.9
UKP308+H2308 308+HE2308 308+HS2308	1-1/4 1-3/8	35	60	220	170	60	17	25	24	116	46	27.5	M14	3.1
UKP309+H2309 309+HA2309 309+HE2309	1-7/16 1-1/2	40	67	245	190	67	20	30	25	129	50	30	M16	4.2
UKP310+H2310 310+HS2310 310+HA2310 310+HE2310	1-5/8 1-11/16 1-3/4	45	75	275	212	75	20	35	27	143	55	32	M16	5.8
UKP311+H2311 311+HA2311 311+HS2311 311+HE2311	1-11/16 1-7/8 2	50	80	310	236	80	20	38	30	154	59	33.5	M16	7.4
UKP312+H2312 312+HS2312	2-1/8	55	85	330	250	85	25	38	32	165	62	36.5	M20	9.3
UKP313+H2313 313+HA2313 313+HE2313 313+HS2313	2-3/16 2-1/4 2-3/8	60	90	340	260	90	25	38	33	178	65	38.5	M20	10
UKP315+H2315 315+HA2315 315+HE2315	2-7/16 2-1/2	65	95	360	280	90	27	40	35	187	73	42.5	M22	15
UKP316+H2316 316+HA2316 316+HE2316	2-11/16 2-3/4	70	100	377	290	100	33	40	35	198	78	44.5	M22	18
UKP317+H2317 317+HA2317 317+HE2317	2-15/16 3	75	106	398	300	110	33	40	40	210	82	48	M22	20
UKP318+H2318		80	112	420	320	110	33	45	40	222	86	48	M27	24
UKP319+H2319 319+HE2319	3-1/4	85	125	470	360	120	36	50	46	250	90	52	M30	29
UKP320+H2320 320+HE2320	3-1/2	90	140	488	380	120	36	50	50	275	97	51	M30	35

NOTE: 1 Grease fittings available at 90° and 45° positions.

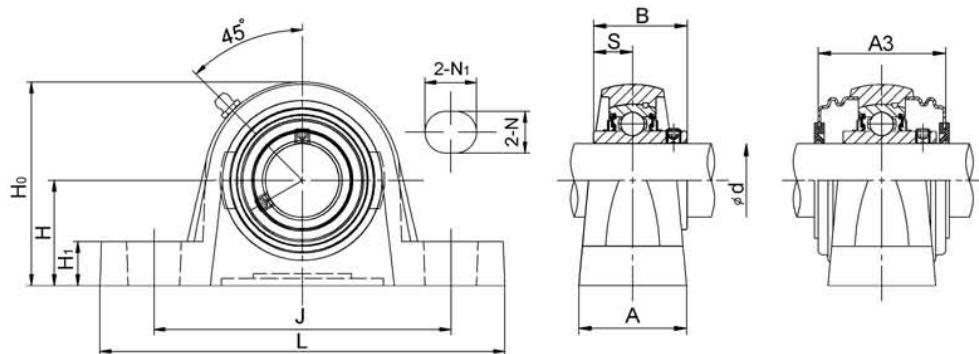

UCPE200 Series

Unit No.	Shaft Dia		Dimensions (mm)										Bolt Size		Weight (kg)	
	d		H	L	J	A	N	N1	H1	H0	B	S	A3	(mm)		(in)
	(in)	(mm)														
UCPE201		12														
201-8	1/2	15														
202			30.2	124	95	31	11	15	14	57.1	26	10		M8	5/16	0.57
202-9	9/16															
203-10	5/8	17														
203																
203-11	11/16															
UCPE204		20														
204-12	3/4		33.3	127	95	38	13	16	15	65	31	12.7	46.4	M10	3/8	0.82
UCPE205		25														
205-14	7/8		36.5	140	105	38	13	16	16	70	34.1	14.3	48	M10	3/8	0.94
205-15	15/16															
205-16	1															
UCPE206		30														
206-17	1-1/16		42.9	160	121	48	17	21	18	83	38.1	15.9	52	M14	1/2	1.46
206-18	1-1/8															
206-19	1-3/16															
206-20	1-1/4															
UCPE207		35														
207-20	1-1/4		47.6	167	127	48	17	21	19	94	42.9	17.5	59	M14	1/2	1.76
207-21	1-5/8															
207-22	1-3/8															
207-23	1-7/16															
UCPE208		40														
208-24	1-1/2		49.2	180	137	54	17	25	19	101	49.2	19.0	68.2	M14	1/2	2.13
208-25	1-9/16															
UCPE209		45														
209-26	1-5/8		54	190	146	54	17	25	20	108	49.2	19.0	70	M14	1/2	2.43
209-27	1-11/16															
209-28	1-3/4															
UCPE210		50														
210-30	1-7/8		57.2	206	159	60	20	25	22	114	51.6	19.0	76	M16	5/8	3.13
210-31	1-15/16															
210-32	2															
UCPE211		55														
211-32	2		63.5	219	171	60	20	25	22	126	55.6	22.2	76	M16	5/8	3.87
211-34	2-1/8															
211-35	2-3/16															
UCPE212		60														
212-36	2-1/4		69.9	241	184	70	20	25	25	138	65.1	25.4	89	M16	5/8	5.51
212-38	2-3/8															
212-39	2-7/16															
UCPE213		65														
213-40	2-1/2		76.2	265	203	70	25	29	27	150	65.1	25.4	89	M20	3/4	6.63
UCPE214		70														
214-44	2-3/4		79.4	266	210	72	25	31	27	156	74.6	30.2	98	M20	3/4	7.46
UCPE215		75														
215-47	2-15/16		82.6	275	217	74	25	31	28	163	77.8	33.3	97	M20	3/4	8.21
215-48	3															

NOTE: Open/close(s/sm) covers are optional

BEARINGS

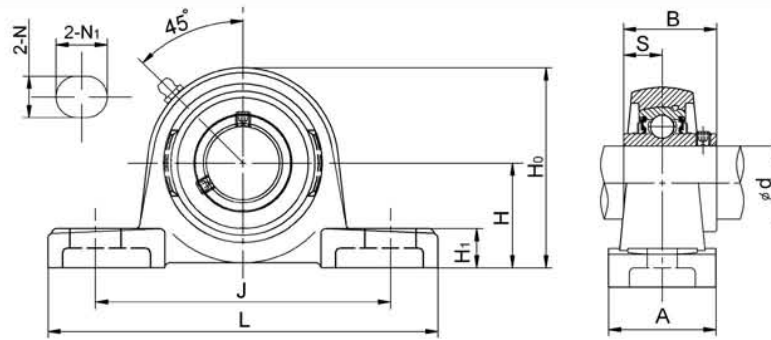

UCAK200 Series

Unit No.	Shaft Dia		Dimensions (mm)										Bolt Size (mm)	Weight (kg)	
	d		H	L	J	A	N	N ₁	H ₁	H ₀	B	S			
	(in)	(mm)													
UCAK201 201-8	1/2	12													
UCAK202 202-10	5/8	15	27	121	89	35	12	16	13	54	26	10	M10	0.74	
UCAK203 204-12	3/4	17													
UCAK204 204-12	3/4	20	31.8	133	98	41	12	16	14.3	64	31	12.7	M10	0.77	
UCAK205 205-13 205-14 205-15 205-16	13/16 7/8 15/16 1	25													
UCAK206 206-17 206-18 206-19 206-20	1-1/16 1-1/8 1-3/16 1-1/4	30													
UCAK207 207-20 207-21 207-22 207-23	1-1/4 1-5/16 1-3/8 1-7/16	35													
UCAK208 208-24 208-25	1-1/2 1-9/16	40													
UCAK209 209-26 209-27 209-28	1-5/8 1-11/16 1-3/4	45													
UCAK210 210-29 210-30 210-31 210-32	1-13/16 1-7/8 1-15/16 2	50													
UCAK211 211-32 211-33 211-34 211-35	2 2-1/16 2-1/8 2-3/16	55													
UCAK212 212-36 212-37 212-38 212-39	2-1/4 2-5/16 2-3/8 2-7/16	60													
UCAK213 213-40 213-41	2-1/2 2-9/16	65													
UCAK214 214-42 214-43 214-44	2-5/8 2-11/16 2-3/4	70													
UCAK215 215-45 215-46 215-47 215-48	2-13/16 2-7/8 2-15/16 3	75													

NOTE: 1 Grease fittings available at 90° and 45° positions.

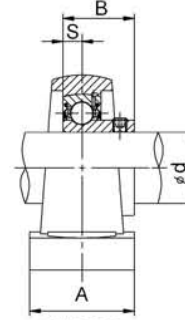
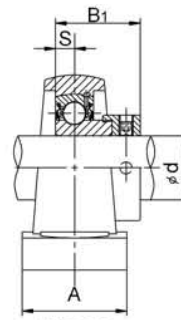
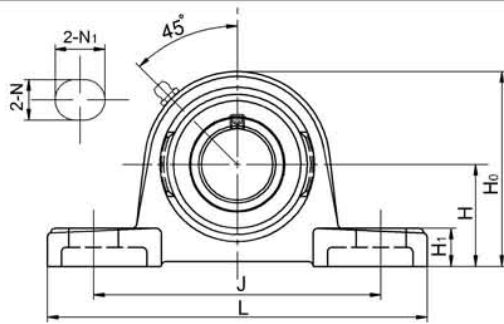

• SALP200

• SBLP200

SALP200 SBLP200 Series

Unit No.	Shaft Dia		Dimensions (mm)										Bolt Size (mm)	Weight (kg)	
	d		H	L	J	A	N	N ₁	H ₁	H ₀	B ₁	S			
	(in)	(mm)													
SALP201		12													
201-8	1/2	15	30.2	114	87	25	11	16	12	57	28.6	6.5	M10	0.4	
202															
202-9	9/16														
202-10	5/8														
203		17													
203-11	11/16														
SALP204		20	33.3	125	97	27	11.5	16	14	63.8	30.9	7.5	M10	0.52	
204-12	3/4														
SALP205		25	36.5	130	100	29	11.5	16	15	69.5	30.9	7.5	M10	0.61	
205-14	7/8														
205-15	15/16														
205-16	1														
SALP206		30	42.9	156	121	33	14	21	16	82	35.7	9	M12	0.73	
206-17	1-1/16														
206-18	1-1/8														
206-19	1-3/16														
206-20	1-1/4														
207		35	47.6	165	127	35	14	21	16	93	38.9	9.5	M12	1.0	
207-20	1-1/4														
207-21	1-5/16														
207-22	1-3/8														
207-23	1-7/16														

Unit No.	Shaft Dia		Dimensions (mm)										Bolt Size (mm)	Weight (kg)	
	d		H	L	J	A	N	N ₁	H ₁	H ₀	B	S			
	(in)	(mm)													
SBLP201		12													
201-8	1/2	15	30.2	114	87	25	11	16	12	57	22	6.5	M10	0.4	
202															
202-9	9/16														
202-10	5/8														
203		17													
203-11	11/16														
SBLP204		20	33.3	125	97	27	11.5	16	14	63.8	25	7.5	M10	0.52	
204-12	3/4														
SBLP205		25	36.5	130	100	29	11.5	16	15	69.5	27	7.5	M10	0.61	
205-14	7/8														
205-15	15/16														
205-16	1														
SBLP206		30	42.9	156	121	33	14	21	16	82	30	9	M12	0.73	
206-17	1-1/16														
206-18	1-1/8														
206-19	1-3/16														
206-20	1-1/4														
SBLP207		35	47.6	165	127	35	14	21	16	93	32	9.5	M12	1.0	
207-20	1-1/4														
207-21	1-5/16														
207-22	1-3/8														
207-23	1-7/16														

NOTE: Grease fittings available at 90° and 45° positions.

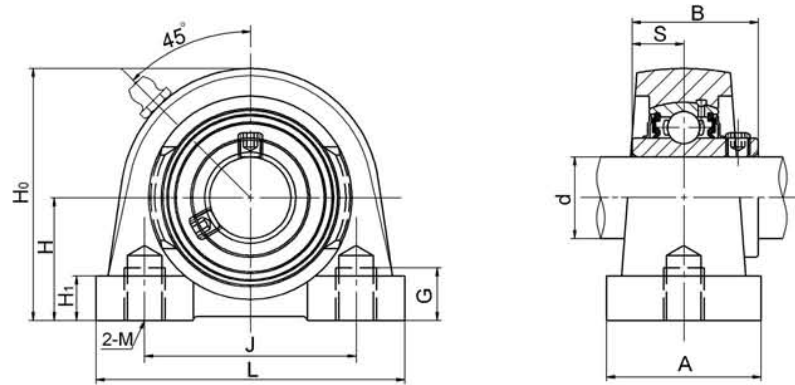

UCPA200 Series

Unit No.	Shaft Dia		Dimensions(mm)										Bolt Size (mm)	Weight (kg)
	d (in)	d (mm)	H	L	J	A	G	H ₁	H ₀	M	B	S		
UCWPA201 202 203		12 15 17	30.2	71	48	36	9	10	57	M10	27.4	11.5	M10	0.67 0.63 0.62
UCPA201 201-8	1/2	12	30.2	76	52	38	13	11	62	M10	31.0	12.7	M10	0.67
UCPA202 202-9 202-10	9/16 5/8	15	30.2	76	52	38	13	11	62	M10	31.0	12.7	M10	0.63
UCPA203 203-11	11/16	17	30.2	76	52	38	13	11	62	M10	31.0	12.7	M10	0.62
UCPA204 204-12	3/4	20	30.2	76	52	38	13	11	62	M10	31.0	12.7	M10	0.60
UCPA205 205-14 205-15 205-16	7/8 15/16 1	25	36.5	84	56	38	15	12	72	M10	34.1	14.3	M10	0.81
UCPA206 206-17 206-18 206-19 206-20	1-1/16 1-1/8 1-3/16 1-1/4	30	42.9	94	66	48	18	12	84	M14	38.1	15.9	M14	1.20
UCPA207 207-20 207-21 207-22 207-23	1-1/4 1-5/16 1-3/8 1-7/16	35	47.6	110	80	48	20	13	95	M14	42.9	17.5	M14	1.70
UCPA208 208-24 208-25	1-1/2 1-9/16	40	49.2	116	84	54	20	13	100	M14	49.2	19.0	M14	1.90
UCPA209 209-26 209-27 209-28	1-5/8 1-11/16 1-3/4	45	54.2	120	90	54	25	13	108	M14	49.2	19.0	M14	2.20
UCPA210 210-30 210-31 210-32	1-7/8 1-15/16 2	50	57.2	130	94	60	25	14	116	M16	51.6	19.0	M16	2.60
UCPA211 211-32 211-34 211-35	2 2-1/8 2-3/16	55	63.5	140	104	66	25	14	125	M16	55.6	22.2	M16	3.00
UCPA212 212-36 212-38 212-39	2-1/4 2-3/8 2-7/16	60	69.9	150	114	68	25	17	138	M16	65.1	25.4	M16	4.24

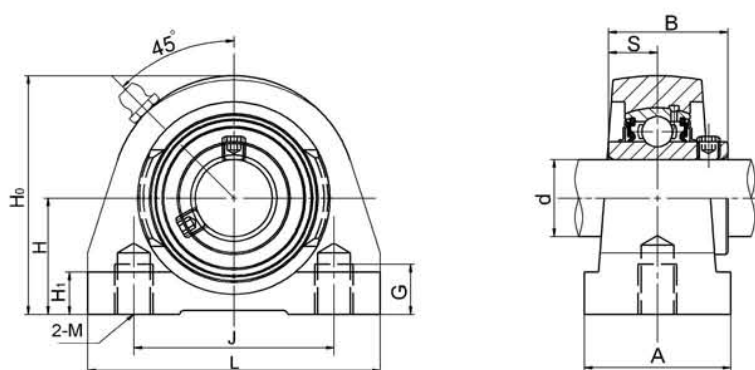

UCPW200 Series

Unit No.	Shaft Dia		Dimensions (mm)										Bolt Size (mm)	Weight (kg)	
	d		H	L	J	A	M	G	H ₀	B	S	H ₁			
	(in)	(mm)													
UCPW201 201-8		12	33.3	65	50.8	32	M8	13	64	31	12.7	13	M8	0.8	
UCPW202 202-9 202-10		15	33.3	65	50.8	32	M8	13	64	31	12.7	13	M8	0.79	
	9/16														5/8
UCPW203 203-11		17	33.3	65	50.8	32	M8	13	64	31	12.7	13	M8	0.77	
UCPW204 204-12		20	33.3	65	50.8	32	M8	13	64	31	12.7	13	M8	0.76	
UCPW205 205-14 205-15 205-16		25	36.5	70	50.8	36	M10	13	70	34.1	14.3	13	M10	0.91	
	7/8														15/16
	1														
UCPW206 206-17 206-18 206-19 206-20		30	42.9	98	76.2	38	M10	16	82	38.1	15.9	15	M10	1.42	
	1-1/16														
	1-1/8														
	1-3/16														1-1/4
UCPW207 207-20 207-21 207-22 207-23		35	47.6	103	82.6	45	M10	19	93	42.9	17.5	15	M10	1.91	
	1-1/4														
	1-5/16														
	1-3/8														1-7/16
UCPW208 208-24 208-25		40	49.2	116	88.9	48	M12	19	99	49.2	19	15	M12	2.28	
	1-1/2														1-9/16
UCPW209 209-26 209-27 209-28		45	53.9	120	95.3	48	M12	19	107	49.2	19	18	M12	2.61	
	1-5/8														
	1-11/16														1-3/4
UCPW210 210-30 210-31 210-32		50	57.2	135	101.6	54	M16	22	115	51.6	19	18	M16	3.28	
	1-7/8														
	1-15/16														2

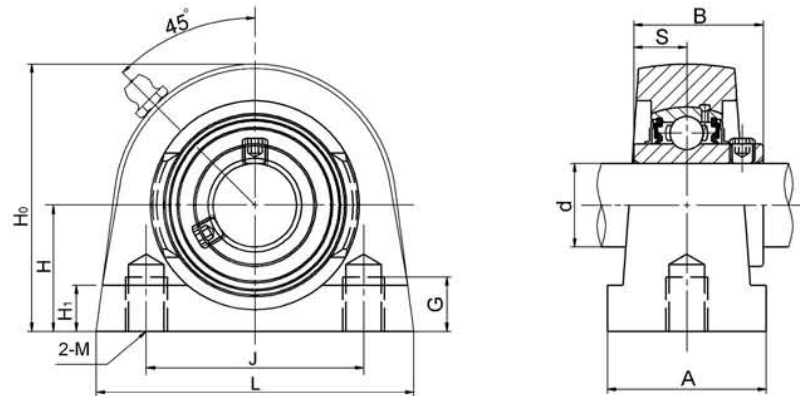

UCPG200 Series

Unit No.	Shaft Dia		Dimensions (mm)										Bolt Size (mm)	Weight (kg)
	d		H	L	J	A	M	G	H ₁	H ₀	B	S		
	(in)	(mm)												
UCPG201 201-8	1/2	12	33.3	70	49	38	M8	14	11	64	31	12.7	M8	0.8
UCPG202 UCPG202-9 UCPG202-10	9/16 5/8	15	33.3	70	49	38	M8	14	11	64	31	12.7	M8	0.79
UCPG203 UCPG203-11	11/16	17	33.3	70	49	38	M8	14	11	64	31	12.7	M8	0.77
UCPG204 UCPG204-12	3/4	20	33.3	70	49	38	M8	14	11	64	31	12.7	M8	0.76
UCPG205 UCPG205-14 UCPG205-15 UCPG205-16	7/8 15/16 1	25	36.5	75	50	38	M10	15	12	70	34.1	14.3	M10	0.91
UCPG206 UCPG206-17 UCPG206-18 UCPG206-19 UCPG206-20	1-1/16 1-1/8 1-3/16 1-1/4	30	42.9	85	60	48	M10	17	12	84	38.1	15.9	M10	1.42
UCPG207 UCPG207-20 UCPG207-21 UCPG207-22 UCPG207-23	1-1/4 1-5/16 1-3/8 1-7/16	35	47.6	100	68	48	M12	17	13	93	42.9	17.5	M12	1.91
UCPG208 UCPG208-24 UCPG208-25	1-1/2 1-9/16	40	49.2	110	78	54	M12	20	13	98	49.2	19	M12	2.28
UCPG209 UCPG209-26 UCPG209-27 UCPG209-28	1-5/8 1-11/16 1-3/4	45	53.9	120	85	54	M12	20	14	106	49.2	19	M12	2.61
UCPG210 UCPG210-30 UCPG210-31 UCPG210-32	1-7/8 1-15/16 2	50	57.2	135	95	60	M16	21	14	114	51.6	19	M16	3.28

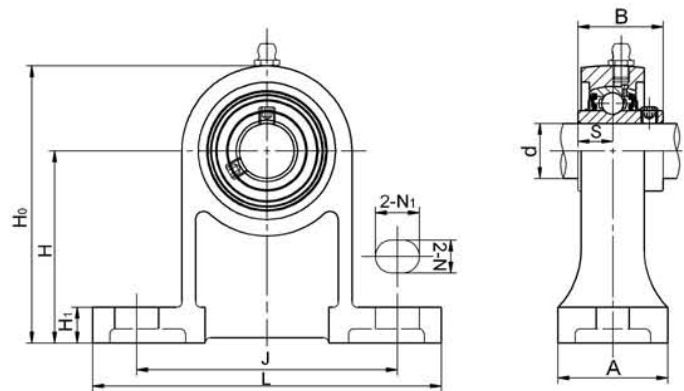

UCPH200 Series

Unit No.	Shaft Dia		Dimensions(mm)										Bolt Size (mm)	Weight (kg)
	d		H	L	J	A	N	N ₁	H ₁	H ₀	B	S		
	(in)	(mm)												
UCPH201 201-8	1/2	12	70	127	95	40	13	19	15	101	31	12.7	M10	0.96
UCPH202 UCPH202-9 UCPH202-10	9/16 5/8	15	70	127	95	40	13	19	15	101	31	12.7	M10	0.96
UCPH203 UCPH203-11	11/16	17	70	127	95	40	13	19	15	101	31	12.7	M10	0.96
UCPH204 UCPH204-12	3/4	20	70	127	95	40	13	19	15	101	31	12.7	M10	0.96
UCPH205 UCPH205-14 UCPH205-15 UCPH205-16	7/8 15/16 1	25	80	140	105	50	13	19	16	114	34.1	14.3	M10	1.20
UCPH206 UCPH206-17 UCPH206-18 UCPH206-19 UCPH206-20	1-1/16 1-1/8 1-3/16 1-1/4	30	90	161	121	50	17	21	18	130	38.1	15.9	M14	1.60
UCPH207 UCPH207-20 UCPH207-21 UCPH207-22 UCPH207-23	1-1/4 1-5/16 1-3/8 1-7/16	35	95	167	127	60	17	21	19	140	42.9	17.5	M14	2.10
UCPH208 UCPH208-24 UCPH208-25	1-1/2 1-9/16	40	100	178	137	70	17	21	20	150	49.2	19.0	M14	2.70
UCPH209 UCPH209-26 UCPH209-27 UCPH209-28	1-5/8 1-11/16 1-3/4	45	105	190	146	70	17	21	20	158	49.2	19.0	M14	3.10
UCPH210 UCPH210-30 UCPH210-31 UCPH210-32	1-7/8 1-15/16 2	50	110	206	159	70	20	23	22	165	51.6	19.0	M16	3.50
UCPH211 UCPH211-32 UCPH211-34 UCPH211-35	2 2-1/8 2-3/16	55	120	219	171	75	20	23	23	181	55.6	22.2	M16	4.07
UCPH212 UCPH212-36 UCPH212-38 UCPH212-39	2-1/4 2-3/8 2-7/16	60	130	243	184	85	20	23	24	197	65.1	25.4	M16	6.31

BEARINGS

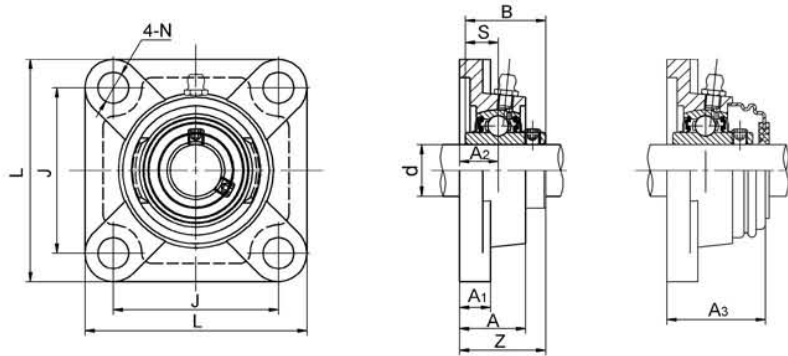

UCF200 Series

Unit No.	Shaft Dia		Dimensions(mm)										Bolt Size (mm)	Weight (kg)
	d (in)	d (mm)	L	J	A ₂	A ₁	A	N	B	S	Z	A ₃		
UCWF201 202 203		12 15 17	76	54	15	11	25.5	12	27.4	11.5	30.9		M10	0.72 0.62 0.61
UCF201 201-8	1/2	12	86	64	15	12	25.5	12	31	12.7	33.3		M10	0.61
UCF202 202-9 202-10	9/16 5/8	15	86	64	15	12	25.5	12	31	12.7	33.3		M10	0.61
UCF203 203-11	11/16	17	86	64	15	12	25.5	12	31	12.7	33.3		M10	0.61
UCF204 204-12	3/4	20	86	64	15	12	25.5	12	31	12.7	33.3	38.2	M10	0.61
UCF205 205-14 205-15 205-16	7/8 15/16 1	25	95	70	16	14	27	12	34.1	14.3	35.8	40	M10	0.80
UCF206 206-17 206-18 206-19 206-20	1-1/16 1-1/8 1-3/16 1-1/4	30	108	83	18	14	31	12	38.1	15.9	40.2	44	M10	1.00
UCF207 207-20 207-21 207-22 207-23	1-1/4 1-5/16 1-3/8 1-7/16	35	117	92	19	16	34	14	42.9	17.5	44.4	48.5	M12	1.40
UCF208 208-24 208-25	1-1/2 1-9/16	40	130	102	21	16	36	16	49.2	19	51.2	55.1	M14	1.80
UCF209 209-26 209-27 209-28	1-5/8 1-11/16 1-3/4	45	137	105	22	18	38	16	49.2	19	52.2	57	M14	2.20
UCF210 210-30 210-31 210-32	1-7/8 1-15/16 2	50	143	111	22	18	40	16	51.6	19	54.6	60	M14	2.40
UCF211 211-32 211-34 211-35	2 2-1/8 2-3/16	55	162	130	25	20	43	19	55.6	22.2	58.4	63	M16	3.50
UCF212 212-36 212-38 212-39	2-1/4 2-3/8 2-7/16	60	175	143	29	20	48	19	65.1	25.4	68.7	73.5	M16	4.20
UCF213 213-40	2-1/2	65	187	149	30	22	50	19	65.1	25.4	69.7	74.5	M16	5.30
UCF214 214-44	2-3/4	70	193	152	31	22	54	19	74.6	30.2	75.4	80	M16	5.90
UCF215 215-47 215-48	2-15/16 3	75	200	159	34	22	56	19	77.8	33.3	78.5	82.5	M16	6.30
UCF216 217-52		80	208	165	34	22	58	23	82.6	33.3	83.3	89	M20	7.30
UCF217 217-52	3-1/4	85	220	175	36	24	63	23	85.7	34.1	87.6	92.1	M20	8.90
UCF218 218-56	3-1/2	90	235	187	40	25	68	23	96	39.7	96.3	102	M20	11.60

NOTE: 1 Open / Close (S/SM) covers are optional

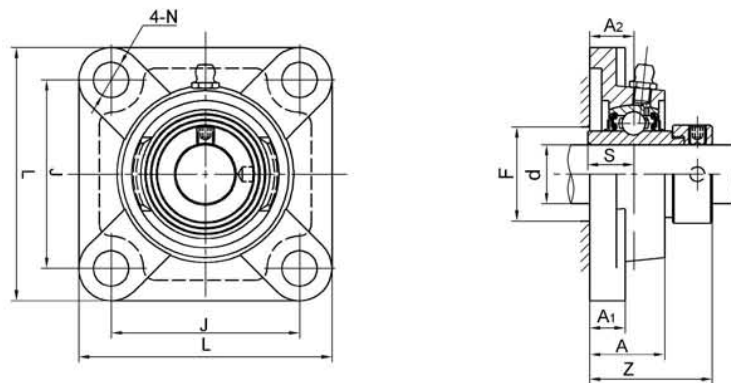

NAF200 Series

Unit No.	Shaft Dia		Dimensions (mm)									Bolt Size (mm)	Weight (kg)
	d		L	J	A ₂	A ₁	A	N	S	Z	F		
	(in)	(mm)											
NAF 201S		12											
201-8S	1/2	15											
202S		15	76	54	15	11	25.5	12	13.9	38.4	---	M10	0.5
202-10S	5/8	17											
203S		17											
203-11S	11/16												
NAF 201		12											
201-8	1/2	12	86	64	15	12	25.5	12	17.1	41.6	32	M10	0.66
202		15	86	64	15	12	25.5	12	17.1	41.6	32	M10	0.66
202-10	5/8												
203		17	86	64	15	12	25.5	12	17.1	41.6	32	M10	0.66
203-11	11/16												
204		20	86	64	15	12	25.5	12	17.1	41.6	32	M10	0.66
204-12	3/4												
NAF 205		25											
205-14	7/8		95	70	16	14	27	12	17.5	42.9	36	M10	0.80
205-15	15/16												
205-16	1												
NAF 206		30											
206-18	1-1/8		108	83	18	14	31	12	18.3	48.1	42	M10	1.2
206-19	1-3/16												
206-20	1-1/4												
NAF 207		35											
207-20	1-1/4		117	92	19	16	34	14	18.8	51.3	49	M12	1.6
207-21	1-5/16												
207-22	1-3/8												
207-23	1-7/16												
NAF 208		40											
208-24	1-1/2		130	102	21	16	36	16	21.4	55.9	55	M14	1.9
208-25	1-9/16												
NAF 209		45											
209-26	1-5/8		137	105	22	18	38	16	21.4	56.9	---	M14	2.30
209-27	1-11/16												
209-28	1-3/4												
NAF 210		50											
210-30	1-7/8		143	111	22	18	40	16	24.6	60.1	64	M14	2.60
210-31	1-15/16												
NAF 211		55											
211-32	2		162	130	25	20	43	19	27.8	68.6	71	M16	3.80
211-34	2-1/8												
211-35	2-3/16												
NAF 212		60											
212-36	2-1/4		175	143	29	20	48	19	31	75.8	78	M16	4.80
212-38	2-3/8												
212-39	2-7/16												
NAF 213		65											
213-40	2-1/2		187	149	30	22	50	19	34.3	81.4	85	M16	6
NAF 214		70											
214-44	2-3/4		193	152	31	22	54	19	34.3	82.4	91	M16	6.3
NAF 215		75											
215-48	3		200	159	34	22	56	19	37.3	88.8	96	M16	7.2

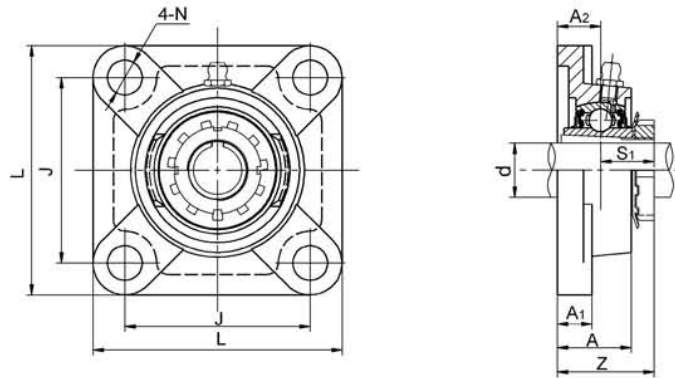

UKF200+H Series

Unit No.	Shaft Dia		Dimensions (mm)								Bolt Size (mm)	Weight (kg)
	d		L	J	A ₂	A ₁	A	N	S ₁	Z		
	(in)	(mm)										
UKF 205+H2305 205+HE2305	3/4	20	95	70	16	14	27	12	18.5	34.5	M10	0.84
UKF 206+H2306 206+HS2306 206+HA2306 206+HE2306	7/8 15/16 1	25	108	83	18	14	31	12	20.5	38.5	M10	1.1
UKF 207+H2307 207+HS2307 207+HA2307	1-1/8 1-3/16	30	117	92	19	16	34	14	22.5	41.5	M12	1.6
UKF 208+H2308 208+HE2308 208+HS2308	1-1/4 1-3/8	35	130	102	21	16	36	16	24.5	45.5	M14	1.9
UKF 209+H2309 209+HA2309 209+HE2309	1-7/16 1-1/2	40	137	105	22	18	38	16	26	48	M14	2.3
UKF 210+H2310 210+HS2310 210+HA2310 210+HE2310	1-5/8 1-11/16 1-3/4	45	143	111	22	18	40	16	27.5	49.5	M14	2.6
UKF 211+H2311 211+HS2311 211+HA2311 211+HE2311	1-7/8 1-15/16 2	50	162	130	25	20	43	19	28.5	53.5	M16	3.4
UKF 212+H2312 212+HS2312	2-1/8	55	175	143	29	20	48	19	31	60	M16	4.1
UKF 213+H2313 213+HA2313 213+HE2313 213+HS2313	2-3/16 2-1/4 2-3/8	60	187	149	30	22	50	19	32	62	M16	5.5
UKF 215+H2315 215+HA2315 215+HE2315	2-7/16 2-1/2	65	200	159	34	22	56	19	35.5	69.5	M16	6.7
UKF 216+H2316 216+HA2316 216+HE2316	2-11/16 2-3/4	70	208	165	34	22	58	23	39	73	M20	7.5
UKF 217+H2317 217+HA2317 217+HE2317	2-15/16 3	75	220	175	36	24	63	23	40	76	M20	9.1
UKF 218+H2318		80	235	187	40	25	68	23	42	82	M20	11.8

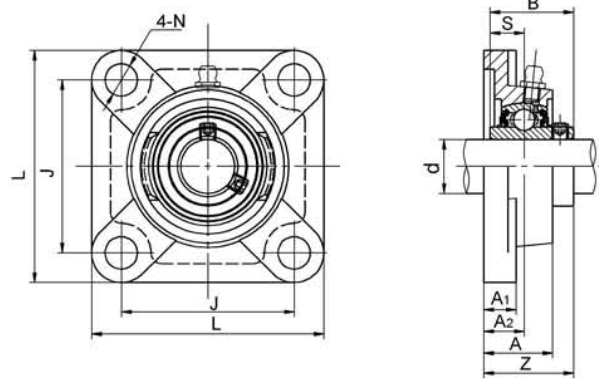

UCFX00 Series

Unit No.	Shaft Dia		Dimensions (mm)									Bolt Size (mm)	Weight (kg)
	d		L	J	A ₂	A ₁	A	N	B	S	Z		
	(in)	(mm)											
UCFX05		25											
05-13	13/16		108	83	18	13	30	12	38.1	15.9	40.2	M10	1.0
05-14	7/8												
05-15	15/16												
05-16	1												
UCFX06		30											
06-17	1-1/16		117	92	19	14	34	16	42.9	17.5	44.4	M14	1.7
06-18	1-1/8												
06-19	1-3/16												
06-20	1-1/4												
UCFX07		35											
07-21	1-5/16		130	101.5	21	14	38	16	49.2	19	51.2	M14	2.1
07-22	1-3/8												
07-23	1-7/16												
UCFX08		40											
08-24	1-1/2		137	105	22	14	40	19	49.2	19	52.2	M16	2.4
08-25	1-9/16												
UCFX09		45											
09-26	1-5/8		143	111	23	14	40	19	51.6	19	55.6	M16	2.5
09-27	1-11/16												
09-28	1-3/4												
09-29	1-13/16												
UCFX10		50											
10-30	1-7/8		162	130	26	20	44	19	55.6	22.2	59.4	M16	3.9
10-31	1-15/16												
10-32	2												
UCFX11		55											
11-33	2-1/16		175	143	29	20	49	19	65.1	25.4	68.7	M16	4.9
11-34	2-1/8												
11-35	2-3/16												
11-36	2-1/4												
11-37	2-5/16												
UCFX12		60											
12-38	2-3/8		187	149	34	21	57	19	65.1	25.4	73.7	M16	5.2
12-39	2-7/16												
UCFX13		65											
13-40	2-1/2		187	149	34	21	59	19	74.6	30.2	78.4	M16	5.3
13-41	2-9/16												
UCFX14		70											
14-42	2-5/8		197	152	37	24	60	23	77.8	33.3	81.5	M20	7.3
14-43	2-11/16												
14-44	2-3/4												
UCFX15		75											
15-45	2-13/16		197	152	40	24	68	23	82.6	33.3	89.3	M20	8.1
15-46	2-7/8												
15-47	2-15/16												
15-48	3												
UCFX16		80											
16-49	3-1/16		214	171	40	24	70	23	85.7	34.1	91.6	M20	9.9
16-50	3-1/8												
16-51	3-3/16												
16-52	3-1/4												
UCFX17		85											
17-53	3-5/16		214	171	40	24	70	23	96	39.7	96.3	M20	11
17-55	3-7/16												

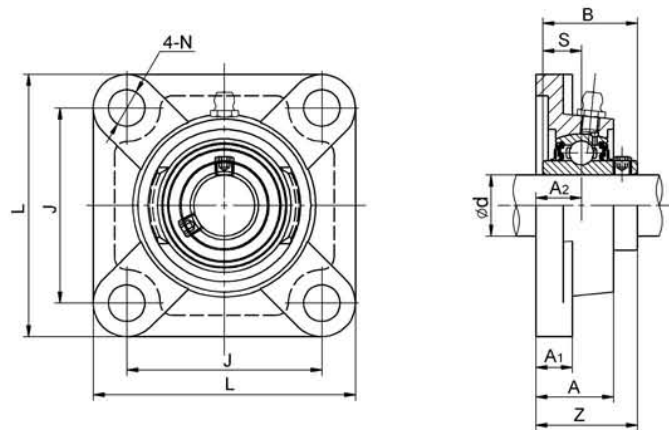

UCF300 Series

Unit No.	Shaft Dia d (mm)	Dimensions(mm)									Bolt size (mm)	Weight (kg)
		L	J	A ₂	A ₁	A	N	B	S	Z		
UCF305	25	110	80	16	13	29	16	38	15	39	M14	1.20
UCF306	30	125	95	18	15	32	16	43	17	44	M14	1.80
UCF307	35	135	100	20	16	36	19	48	19	49	M16	2.20
UCF308	40	150	112	23	17	40	19	52	19	56	M16	2.90
UCF309	45	160	125	25	18	44	19	57	22	61	M16	3.50
UCF310	50	175	132	28	19	48	23	61	22	67	M20	4.80
UCF311	55	185	140	30	20	52	23	66	25	71	M20	5.60
UCF312	60	193	150	33	22	56	23	71	26	78	M20	6.70
UCF313	65	208	166	33	22	58	23	75	30	78	M20	7.80
UCF314	70	224	178	36	25	61	25	78	33	81	M22	10.10
UCF315	75	236	184	39	25	66	25	82	32	89	M22	11.10
UCF316	80	250	196	38	27	68	31	86	34	90	M27	12.80
UCF317	85	260	204	44	27	74	31	96	40	100	M27	15.40
UCF318	90	280	216	44	30	76	35	96	40	100	M30	19.00
UCF319	95	290	228	59	30	94	35	103	41	121	M30	20.6
UCF320	100	310	242	59	32	94	38	108	42	125	M33	25.7
UCF321	105	310	242	59	32	94	38	112	44	128	M33	25.60
UCF322	110	340	266	60	35	96	41	117	46	131	M36	38
UCF324	120	370	290	65	40	110	41	126	51	140	M36	50
UCF326	130	410	320	65	45	115	41	135	54	146	M36	66
UCF328	140	450	350	75	55	125	41	145	59	141	M36	90

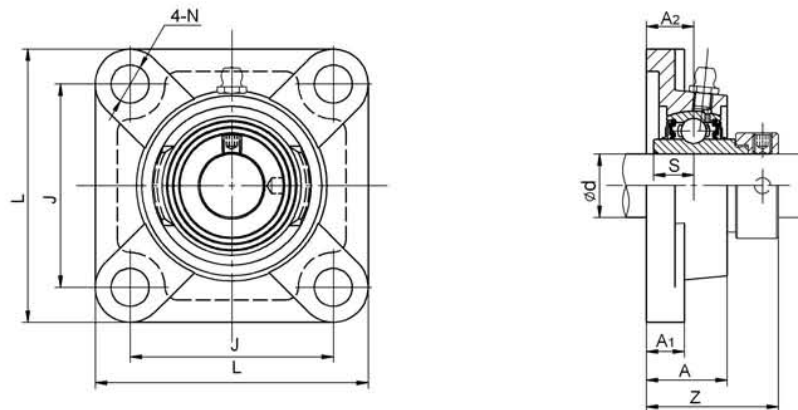

NAF300 Series

Unit No.	Shaft Dia		Dimensions (mm)								Bolt Size (mm)	Weight (kg)	
	d (in)	d (mm)	L	J	A ₂	A ₁	A	N	S	Z			
NAF 305		25											
305-14	7/8		110	80	16	13	29	16	16.7	46.1	M14	1.2	
305-15	15/16												
305-16	1												
NAF 306		30											
306-18	1-1/8		125	95	18	15	32	16	17.5	50.5	M14	1.7	
306-19	1-3/16												
NAF 307		35											
307-20	1-1/4		135	100	20	16	36	19	18.3	53.3	M16	2.0	
307-21	1-5/16												
307-22	1-3/8												
NAF 308		40											
308-24	1-1/2		150	112	23	17	40	19	19.8	60.3	M16	2.8	
308-25	1-9/16												
NAF 309		45											
309-26	1-5/8		160	125	25	18	44	19	19.8	63.9	M16	3.6	
309-27	1-11/16												
309-28	1-3/4												
NAF 310		50											
310-30	1-7/8		175	132	28	19	48	23	24.6	70	M20	4.7	
310-31	1-15/16												
NAF 311		55											
311-32	2		185	140	30	20	52	23	27.8	75.2	M20	5.7	
311-34	2-1/8												
311-35	2-3/16												
NAF 312		60											
312-36	2-1/4		193	150	33	22	56	23	30.95	81.45	M20	6.8	
312-38	2-3/8												
312-39	2-7/16												
NAF 313		65											
313-40	2-1/2		208	166	33	22	58	23	32.55	85.65	M20	8.3	
NAF 314		70											
314-44	2-3/4		224	178	36	25	61	25	34.15	93.95	M22	10.7	
NAF 315		75											
315-48	3		236	184	39	25	66	25	37.3	101.7	M22	12.24	
NAF 316		80											
316-52		80	250	196	38	27	68	31	40.5	103.9	M27	16	
NAF 317		85											
317-52	3-1/4		260	204	44	27	74	31	42.05	111.45	M27	17	
NAF 318		90											
318-56	3-1/2		280	216	44	30	76	35	43.65	116.25	M30	21	
NAF 319		95											
319-60	3-3/4		290	228	59	30	94	35	38.9	142.4	M30	23	
NAF 320		100											
320-64	4		310	242	59	32	94	38	50	137.6	M33	28	

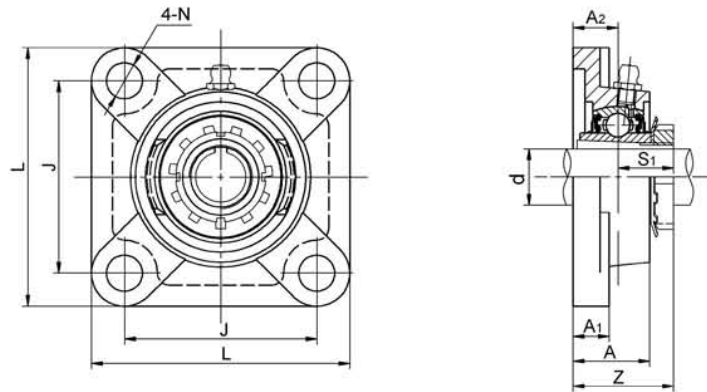

UKF300+H Series

Unit No.	Shaft Dia		Dimensions (mm)								Bolt Size (mm)	Weight (kg)
	d		L	J	A ₂	A ₁	A	N	S ₁	Z		
	(in)	(mm)										
UKF 305+H2305 305+HE2305	3/4	20	110	80	16	13	29	16	21.5	37.5	M14	1.2
UKF 306+H2306 306+HS2306 306+HA2306 306+HE2306	7/8 15/16 1	25	125	95	18	15	32	16	23	41	M14	1.8
UKF 307+H2307 307+HS2307 307+HA2307	1-1/8 1-3/16	30	135	100	20	16	36	19	25.5	45.5	M16	2.2
UKF 308+H2308 308+HE2308 308+HS2308	1-1/4 1-3/8	35	150	112	23	17	40	19	27.5	50.5	M16	2.9
UKF 309+H2309 309+HA2309 309+HE2309	1-7/16 1-1/2	40	160	125	25	18	44	19	30	55	M16	3.5
UKF 310+H2310 310+HS2310 310+HA2310 310+HE2310	1-5/8 1-11/16 1-3/4	45	175	132	28	19	48	23	32	60	M20	4.8
UKF 311+H2311 311+HS2311 311+HA2311 311+HE2311	1-7/8 1-15/16 2	50	185	140	30	20	52	23	33.5	63.5	M20	5.6
UKF 312+H2312 312+HS2312	2-1/8	55	193	150	33	22	56	23	36.5	69.5	M20	6.7
UKF 313+H2313 313+HA2313 313+HE2313 313+HS2313	2-7/16 3-1/4 2-3/8	60	208	166	33	22	58	23	38.5	71.5	M20	7.8
UKF 315+H2315 315+HA2315 315+HS2315	2-7/16 2-1/2	65	236	184	39	25	66	25	42.5	81.5	M22	12
UKF 316+H2316 316+HA2316 316+HE2316	2-11/16 2-3/4	70	250	196	38	27	68	31	44.5	82.5	M27	15
UKF 317+H2317 317+HA2317 317+HE2317	2-15/16 3	75	260	204	44	27	74	31	48	92	M27	16
UKF 318+H2318		80	280	216	44	30	76	35	48	92	M30	20
UKF 319+H2319 319+HE2319	3-1/4	85	290	228	59	30	94	35	52	111	M30	22
UKF 320+H2320 320+HE2320	3-1/2	90	310	242	59	32	94	38	54	113	M33	26

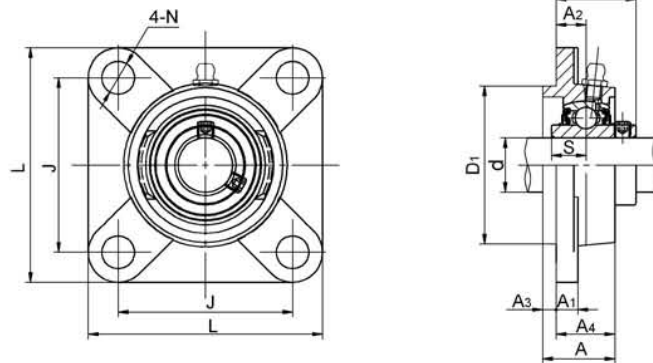

UCFS300 Series

Unit No.	Shaft Dia		Dimensions (mm)										Bolt Size (mm)	Weight (kg)		
	(in)	(mm)	L	J	A ₂	A ₄	A	A ₃	A ₁	N	D ₁	S			Z	
UCFS 305		25														
305-14	7/8		110	80	9	22	29	7	13	16	80	15	32	M14	1.3	
305-15	15/16															
305-16	1															
UCFS 306		30														
306-18	1-1/8		125	95	10	24	32	8	15	16	90	17	36	M14	1.9	
306-19	1-3/16															
UCFS 307		35														
307-20	1-1/4		135	100	11	27	36	9	16	19	100	19	40	M16	2.4	
307-21	1-5/16															
307-22	1-3/8															
UCFS 308		40														
308-24	1-7/8		150	112	13	30	40	10	17	19	115	19	46	M16	3.3	
308-25	1-15/16															
UCFS 309		45														
309-26	2		160	125	14	33	44	11	18	22	125	22	49	M16	4.0	
309-27	2-1/8															
309-28	2-3/16															
UCFS 310		50														
310-30	1-7/8		175	132	16	36	48	12	19	22	140	22	55	M20	5.3	
310-31	1-15/16															
UCFS 311		55														
311-32	2		185	140	17	39	52	13	20	25	150	25	58	M20	6.2	
311-34	2-1/8															
311-36	2-3/16															
UCFS 312		60														
312-36	2-1/4		195	150	19	42	56	14	22	6	160	26	64	M20	7.2	
312-38	2-3/8															
312-39	2-7/16															
UCFS 313		65														
313-40	2-1/2		208	166	15	40	58	18	22	30	175	30	60	M20	8.9	
UCFS 314		70														
314-44	2-3/4		226	178	18	43	61	18	25	31	185	31	65	M22	11	
UCFS 315		75														
315-48	3		236	184	21	48	66	18	25	32	200	32	71	M22	13	
UCFS 316		80														
316-52	3-1/4		260	204	24	54	74	20	27	40	220	40	80	M27	17	
UCFS 317		85														
317-52	3-1/4		260	204	24	54	74	20	27	40	220	40	80	M27	17	
UCFS 318		90														
318-56	3-1/2		280	216	24	56	76	20	30	40	240	40	80	M30	21	
UCFS 319		95														
319-60	3-3/4		290	228	39	74	94	20	30	41	250	101	101	M30	25	
UCFS 320		100														
320-64	4		310	242	39	74	94	20	32	42	260	105	105	M33	30	
UCFS 322		100														
322-64		100	340	266	35	71	96	25	35	46	300	106	106	M36	39	
UCFS 324		120														
324-64		120	370	290	35	80	110	30	40	51	330	110	110	M36	54	
UCFS 326		130														
326-64		130	410	320	35	85	115	30	45	54	360	116	116	M36	71	
UCFS 328		140														
328-64		140	450	350	45	95	125	30	55	59	400	131	131	M36	100	

BEARINGS

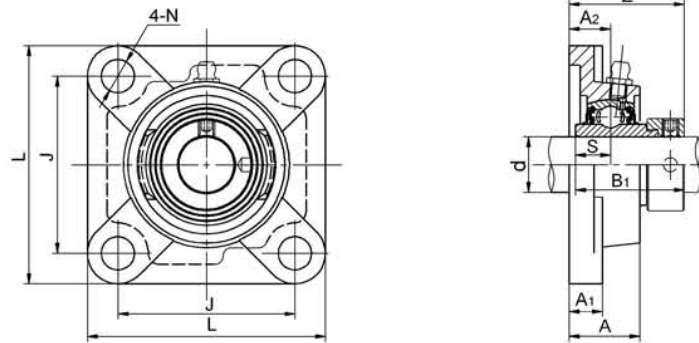

NAFU200 Series

Unit No.	Shaft Dia		Dimensions (mm)									Bolt Size (mm)	Weight (kg)
	d (in)	d (mm)	L	J	A ₂	A ₁	A	N	B ₁	S	Z		
NAFU 201S		12											
201-8S	1/2	15	76	54	15	11	24.5	11.5	37.3	13.9	38.4	M10	0.66
202S	5/8	17											
202-10S	5/8	17											
203S	11/16	17											
203-11S	11/16	17											
NAFU 201		12											
201-8	1/2	15	86	63.5	19	15	29.5	11.5	43.7	17	45.5	M10	0.8
202	5/8	17											
202-10	5/8	17											
203	11/16	20											
203-11	11/16	20											
204	3/4	25											
204-12	3/4	25											
NAFU 205		25											
205-11	7/8	93	70	19	15	30	11.5	44.4	17.4	45.9	M10	0.95	
205-15	15/16												
205-16	1												
NAFU 206		30											
206-18	1-1/8	106	82.5	20	16	32.5	11.5	48.4	18.2	50.1	M10	1.32	
206-19	1-3/16												
206-20	1-1/4												
NAFU 207		35											
207-20	1-1/4	116	92	21	17	35	14	51.1	18.8	53.3	M12	1.77	
207-21	1-5/16												
207-22	1-3/16												
207-23	1-7/16												
NAFU 208		40											
208-24	1-1/2	129	101.5	24	17	39	14	56.3	21.4	58.9	M12	2.22	
208-25	1-9/16												
NAFU 209		45											
209-26	1-5/8	135	105	24	18	40	16	56.3	21.4	58.9	M14	2.63	
209-27	1-11/16												
209-28	1-3/4												
NAFU 210		50											
210-30	1-7/8	143	111	28	20	45	18	62.7	24.6	66.1	M16	2.95	
210-31	1-15/16												
210-32	2												
NAFU 211		55											
211-32	2	162	130	31	21	49	18	71.4	27.7	74.6	M16	4.10	
211-34	2-1/8												
211-35	2-3/16												
NAFU 212		60											
212-36	2-1/4	175	143	34	22	53.5	18	77.8	30.9	80.8	M16	4.86	
212-38	2-3/8												
212-39	2-7/16												
NAFU 213		65											
213-40	2-1/2	184	149	38	22	58	18	85.7	34.1	89.6	M16	5.90	
NAFU 214		70											
214-44	2-3/4	188	152	38	23	60	18	85.7	34.1	89.6	M16	6.45	
NAFU 215		75											
215-47	2-15/16	200	159	41	24	62	18	92.1	37.3	95.8	M16	7.55	
215-48	3												
NAFU 216		80	207	165	42	25	63	22	95.2	37.3	99.9	M20	8.65

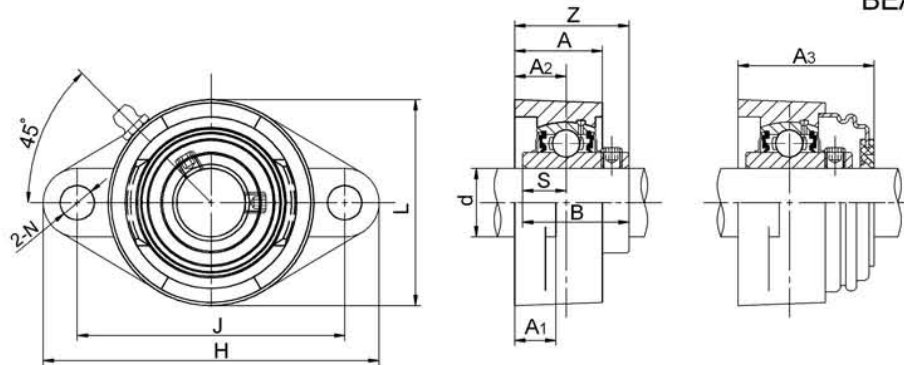

UCFL200 Series

Unit No.	Shaft Dia		Dimensions(mm)										Bolt Size (mm)	Weight (kg)	
	d		H	J	A ₂	A ₁	A	N	L	B	S	Z			A ₃
	(in)	(mm)													
UCWFL201 202 203		12 15 17	97	76.5	15	11	25.5	11.5	55	27.4	11.5	30.9		M10	0.52 0.48 0.37
UCFL201 201-8	1/2	12	113	90	15	11	25.5	12	60	31	12.7	33.3		M10	0.51
UCFL 202 202-9 202-10	9/16 5/8	15	113	90	15	11	25.5	12	60	31	12.7	33.3		M10	0.51
UCFL203 203-11	11/16	17	113	90	15	11	25.5	12	60	31	12.7	33.3		M10	0.51
UCFL204 204-12	3/4	20	113	90	15	11	25.5	12	60	31	12.7	33.3	38.2	M10	0.51
UCFL205 205-14 205-15 205-16	7/8 15/16 1	25	130	99	16	13	27	16	68	34.1	14.3	35.8	40	M14	0.6
UCFL206 206-17 206-18 206-19 206-20	1-1/16 1-1/8 1-3/16 1-1/4	30	148	117	18	13	31	16	80	38.1	15.9	40.2	44	M14	0.9
UCFL207 207-20 207-21 207-22 207-23	1-1/4 1-5/16 1-3/8 1-7/16	35	160	130	19	15	34	16	90	42.9	17.5	44.4	48.5	M14	1.2
UCFL208 208-24 208-25	1-1/2 1-9/16	40	175	144	21	15	36	16	100	49.2	19	51.2	55.1	M14	1.5
UCFL209 209-26 209-27 209-28	1-5/8 1-11/16 1-3/4	45	188	148	22	16	38	19	108	49.2	19	52.2	57	M16	1.9
UCFL210 210-30 210-31 210-32	1-7/8 1-15/16 2	50	197	157	22	16	40	19	115	51.6	19	54.6	60	M16	2.2
UCFL211 211-32 211-34 211-35	2 2-1/8 2-3/16	55	224	184	25	18	43	19	125	55.6	22.2	58.4	63	M16	3.0
UCFL212 212-36 212-38 212-39	2-1/4 2-3/8 2-7/16	60	250	202	29	18	48	23	140	65.1	25.4	68.7	73.5	M20	4.0
UCFL213 213-40	2-1/2	65	258	210	30	22	50	23	155	65.1	25.4	69.7	74.5	M20	5.0
UCFL214 214-44	2-3/4	70	265	216	31	22	54	23	160	74.6	30.2	75.4	80	M20	5.6
UCFL215 215-47 215-48	2-15/16 3	75	275	225	34	22	56	23	165	77.8	33.3	78.5	82.5	M20	6.2
UCFL216		80	290	233	34	22	58	25	180	82.6	33.3	83.3	89	M22	7.8
UCFL217 217-52	3-1/4	85	305	248	36	24	63	25	190	85.7	34.1	87.6	93.1	M22	9.8
UCFL218 218-56	3-1/2	90	320	265	40	24	68	25	205	96	39.7	96.3	102	M22	12.4

NOTE: 1 Open / Close (S/SM) covers are optional

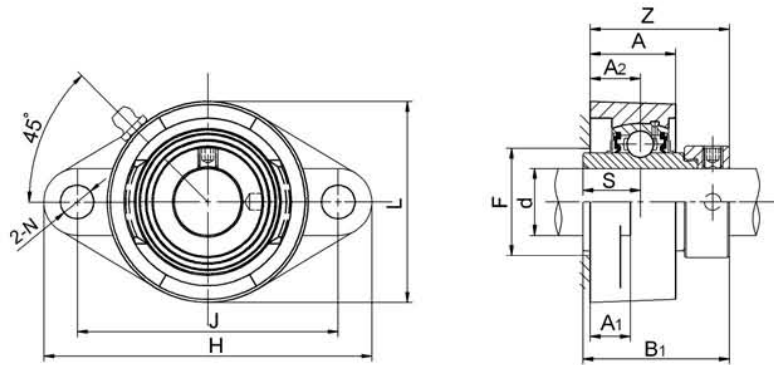

NAFL200 Series

Unit No.	Shaft Dia		Dimensions (mm)											Bolt Size (mm)	Weight (kg)
	d		H	J	A ₂	A ₁	A	N	L	B ₁	S	Z	F		
	(in)	(mm)													
NAFL201S		12													
201-8S	1/2	15													
202S		15	97	76.5	15	11	25.5	11.5	55	37.3	13.9	38.2	--	M10	0.48
202-10S	5/8	17													
203S		17													
203-11S	11/16														
NAFL201		12													
201-8	1/2	15													
202		15													
202-10	5/8	17	113	90	15	11	25.5	12	60	43.7	17.1	41.6	32	M10	0.73
203		17													
203-11	11/16	20													
204		20													
204-12	3/4														
NAFL205		25													
205-14	7/8														
205-15	15/16		130	99	16	13	27	16	68	44.4	17.5	42.9	36	M14	0.80
205-16	1														
NAFL206		30													
206-17	1-1/16														
206-18	1-1/8		148	117	18	13	31	16	80	48.4	18.3	48.1	42	M14	1.2
206-19	1-3/16														
206-20	1-1/4														
NAFL207		35													
207-20	1-1/4														
207-21	1-5/16		160	130	19	15	34	16	90	51.1	18.8	51.3	49	M14	1.6
207-22	1-3/8														
207-23	1-7/16														
NAFL208		40													
208-24	1-1/2		175	144	21	15	36	16	100	56.3	21.4	55.9	55	M14	1.9
208-25	1-9/16														
NAFL209		45													
209-26	1-5/8														
209-27	1-11/16		188	148	22	16	38	19	108	56.3	21.4	56.9	--	M16	2.30
209-28	1-3/4														
NAFL210		50													
210-30	1-7/8		197	157	22	16	40	19	115	62.7	24.6	60.1	64	M16	2.60
210-31	1-15/16														
NAFL211		55													
211-32	2														
211-34	2-1/8		224	184	25	18	43	19	125	71.4	27.8	68.6	71	M16	3.80
211-35	2-3/16														
NAFL212		60													
212-36	2-1/4														
212-38	2-3/8		250	202	29	18	48	23	140	77.8	31	75.8	78	M20	4.80
212-39	2-7/16														
NAFL213		65													
213-40	2-1/2		258	210	30	22	50	23	153	85.7	34.1	81.6	85	M20	6
NAFL214		70													
214-44	2-3/4		265	216	31	22	54	23	160	85.7	34.1	82.6	91	M20	6.3
NAFL215		75													
215-48	3		275	225	34	22	56	23	165	92.1	37.3	88.8	96	M20	7.2
NAFL216		80													
		80	290	233	34	22	58	25	180	95.2	37.3	91.9		M22	7.37

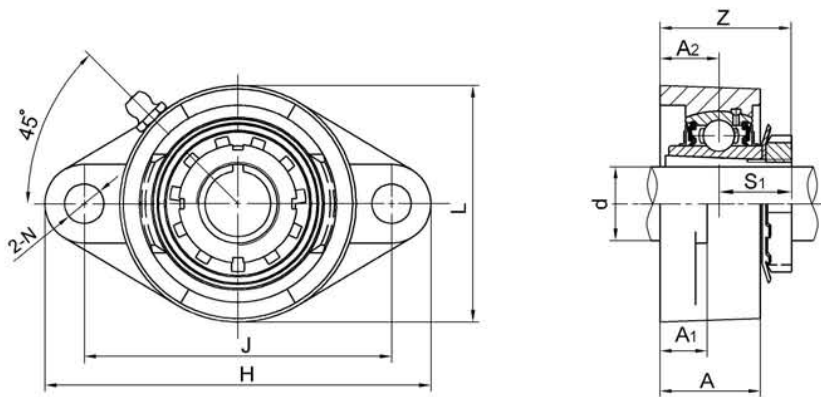

UKFL200+H Series

Unit No.	Shaft Dia		Dimensions (mm)									Bolt Size (mm)	Weight (kg)
	d (in)	d (mm)	H	J	A ₂	A ₁	A	N	L	S ₁	Z		
UKFL205+H2305 205+HE2305	3/4	20	130	99	16	13	27	16	68	18.5	34.5	M14	0.6
UKFL206+H2306 206+HS2306 206+HA2306 206+HE2306	7/8 15/16 1	25	148	117	18	13	31	16	80	20.5	38.5	M14	0.96
UKFL207+H2307 207+HS2307 207+HA2307	1-1/8 1-3/16	30	160	130	19	15	34	16	90	22.5	41.5	M14	1.3
UKFL208+H2308 208+HE2308 208+HS2308	1-1/4 1-3/8	35	175	144	21	15	36	16	100	24.5	45.5	M14	1.6
UKFL209+H2309 209+HA2309 209+HE2309	1-7/16 1-1/2	40	188	148	22	16	38	19	108	26	48	M16	2.0
UKFL210+H2310 210+HS2310 210+HA2310 210+HE2310	1-5/8 1-11/16 1-3/4	45	197	157	22	16	40	19	115	27.5	49.5	M16	2.3
UKFL211+H2311 211+HS2311 211+HA2311 211+HE2311	1-7/8 1-15/16 2	50	224	184	25	18	43	19	125	28.5	53.5	M16	3.3
UKFL212+H2312 212+HS2312	2-1/8	55	250	202	29	18	48	23	140	31	60	M20	4.0
UKFL213+H2313 213+HA2313 213+HE2313 213+HS2313	2-3/16 2-1/4 2-3/8	60	258	210	30	22	50	23	155	32	62	M20	5.1
UKFL215+H2315 215+HA2315 215+HE2315	2-7/16 2-1/2	65	275	225	34	22	56	23	165	35.5	69.5	M20	6.4
UKFL216+H2316 216+HA2316 216+HE2316	2-11/16 2-3/4	70	290	233	34	22	58	25	180	39	73	M22	8.0

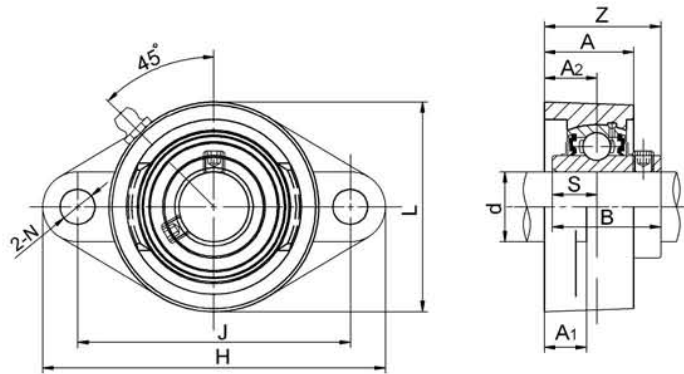

UCFLX00 Series

Unit No.	Shaft Dia		Dimensions (mm)										Bolt Size		Weight (kg)
	d		H	J	A ₂	A ₁	A	N	L	B	S	Z	(mm)	(in)	
	(in)	(mm)													
UCFLX05		25													
05-13	13/16		141	117	18	13	30	12	83	38.1	15.9	40.2	M14	3/8	1.0
05-14	7/8														
05-15	15/16														
05-16	1														
UCFLX06		30													
06-17	1-1/16		156	130	19	15	34	16	95	42.9	17.5	44.4	M14	1/2	1.5
06-18	1-1/8														
06-19	1-3/16														
06-20	1-1/4														
UCFLX07		35													
07-21	1-5/16		171	144	21	16	38	16	105	49.2	19	51.2	M14	1/2	2.0
07-22	1-3/8														
07-23	1-7/16														
UCFLX08		40													
08-24	1-1/2		179	148	22	16	40	16	111	49.2	19	52.2	M14	1/2	2.2
08-25	1-9/16														
UCFLX09		45													
09-26	1-5/8		189	157	23	16	40	16	116	51.6	19	55.6	M16	1/2	2.4
09-27	1-11/16														
09-28	1-3/4														
09-29	1-13/16														
UCFLX10		50													
10-30	1-7/8		216	184	26	18	44	19	133	55.6	22.2	59.4	M16	5/8	3.4
10-31	1-15/16														
10-32	2														

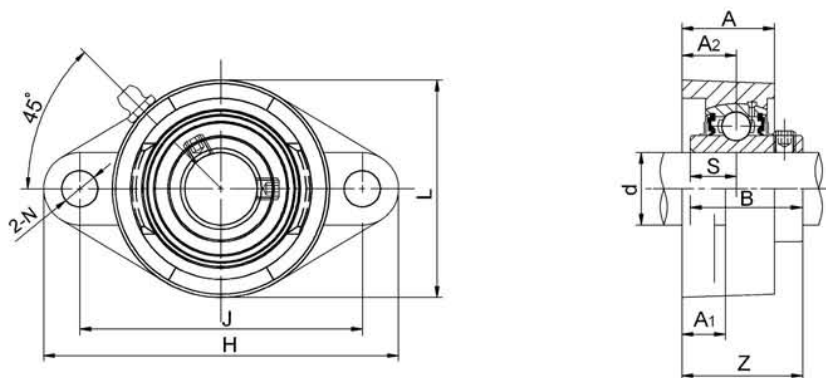

UCFL300 Series

Unit No.	Shaft Dia	Dimensions(mm)										Bolt Size (mm)	Weight (kg)
		H	J	A ₂	A ₁	A	N	L	B	S	Z		
UCFL305	25	150	113	16	13	29	19	80	38	15	39	M16	1.10
UCFL306	30	180	134	18	15	32	23	90	43	17	44	M20	1.60
UCFL307	35	185	141	20	16	36	23	100	48	19	49	M20	2.00
UCFL308	40	200	158	23	17	40	23	112	52	19	56	M20	2.60
UCFL309	45	230	177	25	18	44	25	125	57	22	60	M22	3.63
UCFL310	50	240	187	28	19	48	25	140	61	22	67	M22	4.60
UCFL311	55	250	198	30	20	52	25	150	66	25	71	M22	5.30
UCFL312	60	270	212	33	22	56	31	160	71	26	78	M27	6.40
UCFL313	65	295	240	33	25	58	31	175	75	30	78	M27	8.20
UCFL314	70	315	250	36	28	61	35	185	78	33	81	M30	10.00
UCFL315	75	320	260	39	30	66	35	195	82	32	89	M30	11.00
UCFL316	80	355	285	38	32	68	38	210	86	34	90	M33	14.30
UCFL317	85	370	300	44	32	74	38	220	96	40	100	M33	16.20
UCFL318	90	385	315	44	36	76	38	235	96	40	100	M33	19.20
UCFL319	95	405	330	59	40	94	41	250	103	41	121	M36	21.80
UCFL320	100	440	360	59	40	94	44	270	108	42	125	M39	26.50
UCFL321	105	440	360	59	40	94	44	270	112	44	127	M39	28.20
UCFL322	110	470	390	60	42	96	44	300	117	46	131	M39	33.10
UCFL324	120	520	430	65	48	110	47	330	126	51	140	M42	45.70
UCFL326	130	550	460	65	50	115	47	360	135	54	146	M42	57.50
UCFL328	140	600	500	75	60	125	51	400	145	59	161	M45	79.70

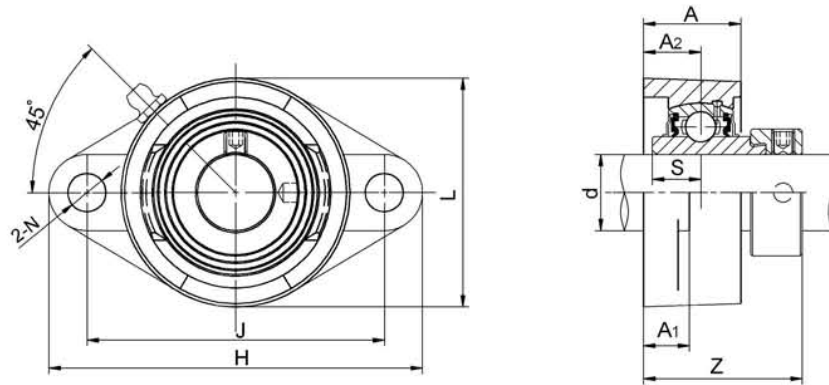

NAFL300 Series

Unit No.	Shaft Dia		Dimensions (mm)									Bolt Size (mm)	Weight (kg)
	d		H	J	A ₂	A ₁	A	N	L	S	Z		
	(in)	(mm)											
NAFL305		25											
305-14	7/8		150	113	16	13	29	19	80	16.7	46.1	M16	1.1
305-15	15/16												
305-16	1												
NAFL306		30											
306-18	1-1/8		180	134	18	15	32	23	90	17.5	50.5	M20	1.6
306-19	1-3/16												
NAFL307		35											
307-20	1-1/4												
307-21	1-5/16		185	141	20	16	36	23	100	18.3	53.3	M20	2.0
307-22	1-3/8												
307-23	1-7/16												
NAFL308		40											
308-24	1-1/2		200	158	23	17	40	23	112	19.8	60.3	M20	2.6
308-25	1-9/16												
NAFL309		45											
309-26	1-5/8		230	177	25	18	44	25	125	19.8	63.9	M22	3.6
309-27	1-11/16												
309-28	1-3/4												
NAFL310		50											
310-30	1-7/8		240	187	28	19	48	25	140	24.6	70	M22	4.6
310-31	1-15/16												
NAFL311		55											
311-32	2		250	198	30	20	52	25	150	27.8	75.2	M22	5.3
311-34	2-1/8												
311-35	2-3/16												
NAFL312		60											
312-36	2-1/4		270	212	33	22	56	31	160	29.5	80	M27	6.4
312-38	2-3/8												
312-39	2-7/16												
NAFL313		65											
313-40	2-1/2		295	240	33	25	58	31	175	32.55	86.2	M27	8.2
NAFL314		70											
314-44	2-3/4		315	250	36	28	61	35	185	34.15	93.95	M30	9.5
NAFL315		75											
315-48	3		320	260	39	30	66	35	195	37.3	101.7	M30	11
NAFL316		80											
			355	285	38	32	68	38	210	40.5	103.9	M33	14

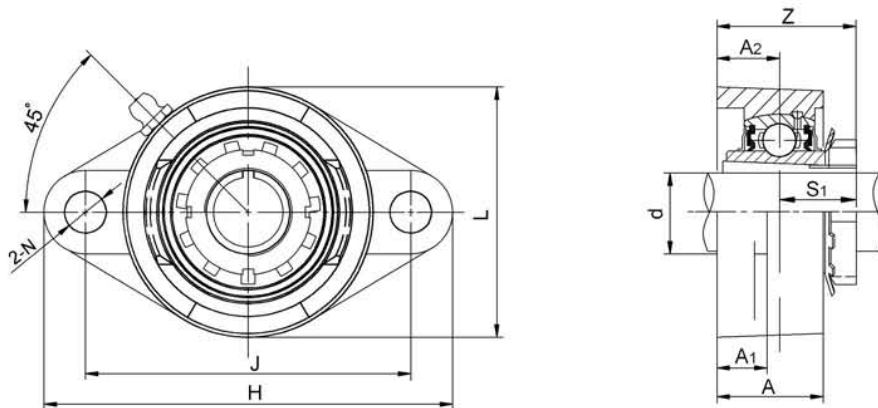

UKFL300+H Series

Unit No.	Shaft Dia		Dimensions (mm)									Bolt Size (mm)	Weight (kg)
	d		H	J	A ₂	A ₁	A	N	L	S ₁	Z		
	(in)	(mm)											
UKFL305+H2305 305+HE2305	3/4	20	150	113	16	13	29	19	80	21.5	37.5	M16	1.1
UKFL306+H2306 306+HS2306 306+HA2306 306+HE2306	7/8 15/16 1	25	180	134	18	15	32	23	90	23	41	M20	1.5
UKFL307+H2307 307+HS2307 307+HA2307	1-1/8 1-3/16	30	185	141	20	16	36	23	100	25.5	45.5	M20	1.8
UKFL308+H2308 308+HE2308 308+HS2308	1-1/4 1-3/8	35	200	158	23	17	40	23	112	27.5	50.5	M20	2.5
UKFL309+H2309 309+HA2309 309+HE2309	1-7/16 1-1/2	40	230	177	25	18	44	25	125	30	55	M22	3.5
UKFL310+H2310 310+HS2310 310+HA2310 310+HE2310	1-5/8 1-11/16 1-3/4	45	240	187	28	19	48	25	140	32	60	M22	4.4
UKFL311+H2311 311+HS2311 311+HA2311 311+HE2311	1-7/8 1-15/16 2	50	250	198	30	20	52	25	150	33.5	63.5	M22	5.1
UKFL312+H2312 312+HS2312	2-1/8	55	270	212	33	22	56	31	160	36.5	69.5	M27	6.0
UKFL313+H2313 313+HA2313 313+HE2313 313+HS2313	2-3/16 2-1/4 2-3/8	60	295	240	33	25	58	31	175	38.5	71.5	M27	7.6
UKFL315+H2315 315+HA2315 315+HE2315	2-7/16 2-1/2	65	320	260	39	30	66	35	195	42.5	81.5	M30	10
UKFL316+H2316 316+HA2316 316+HE2316	2-11/16 2-3/4	70	355	285	38	32	68	38	210	44.5	81.5	M33	13

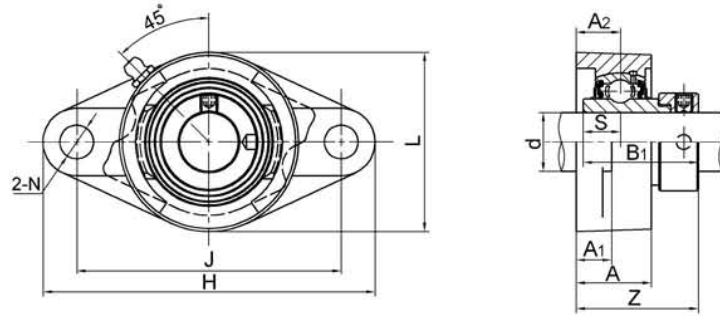

NAFLU200 Series

Unit No.	Shaft Dia		Dimensions (mm)										Bolt Size (mm)	Weight (kg)
	d		H	J	L	A ₂	A ₁	A	N	B ₁	S	Z		
	(in)	(mm)												
NAFLU 201S		12												
201-8S	1/2	15	99	76.5	57	15	11	24.5	11.5	37.3	13.9	38.4	M10	0.66
202S														
202-10S	5/8	17												
203S														
203-11S	11/16													
NAFLU 201		12												
201-8	1/2	15												
202														
202-10	5/8	17	112.5	90	61	19	15	29.5	11.5	43.7	17	45.5	M10	0.73
203														
203-11	11/16	20												
204														
204-12	3/4													
NAFLU 205		25												
205-14	7/8		123	99	70	19	15	30	11.5	44.4	17.4	45.9	M14	0.8
205-15	15/16													
205-16	1													
NAFLU 206		30												
206-18	1-1/8		142	116.5	80	20	13	32.5	11.5	48.4	18.2	50.1	M14	1.2
206-19	1-3/16													
206-20	1-1/4													
NAFLU 207		35												
207-20	1-1/4		158	130	94	21	17	36	14	51.1	18.8	53.3	M14	1.6
207-21	1-5/16													
207-22	1-3/16													
207-23	1-7/16													
NAFLU 208		40												
208-24	1-1/2		172	143.5	103	24	17	39	14	56.3	21.4	58.9	M14	1.9
208-25	1-9/16													
NAFLU 209		45												
209-26	1-5/8		180	148.5	108	24	18	40	16	56.3	21.4	58.9	M16	2.3
209-27	1-11/16													
209-28	1-3/4													
NAFLU 210		50												
210-30	1-7/8		190	157	114	28	20	45	18	62.7	24.6	66.1	M16	2.6
210-31	1-15/16													
210-32	2													
NAFLU 211		55												
211-32	2		217	184	128	31	21	48	18	71.4	27.7	74.6	M16	3.8
211-34	2-1/8													
211-35	2-3/16													
NAFLU 212		60												
212-36	2-1/4		237	202	138	34	21	53	18	77.8	30.9	80.8	M20	4.8
212-38	2-3/8													
212-39	2-7/16													
NAFLU 213		65												
213-40	2-1/2		256	210	152	38	22	56	21	85.7	34.1	89.6	M20	6.0
NAFLU 214		70												
214-44	2-3/4		264	216	157	38	23	58	21	85.7	34.1	89.6	M20	6.3
NAFLU 215		75												
215-47	2-15/16		275	225	164	41	24	62	21	92.1	37.3	95.8	M20	7.2
215-48	3													

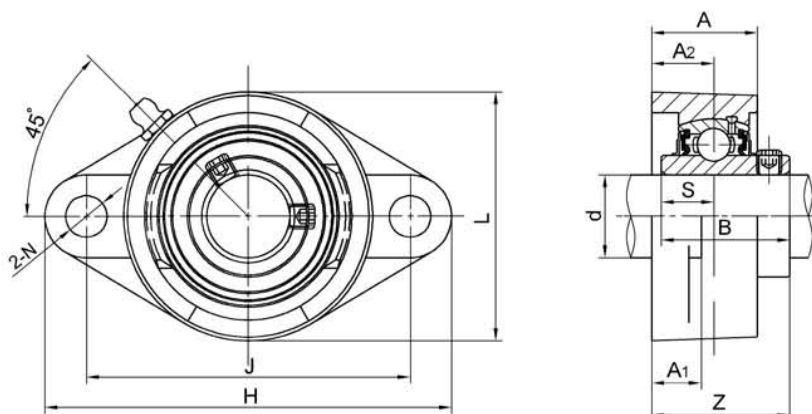

UCFT200 Series

Unit No.	Shaft Dia		Dimensions (mm)										Bolt Size (mm)	Weight (kg)
	d		H	J	A ₂	A ₁	A	N	L	B	S	Z		
	(in)	(mm)												
UCFT201		12												
201-8	1/2	12												
202		15												
202-9	9/16	15	112	76.2	17.1	11	25	10.5	60	26	10	33.1	M8	0.4
202-10	5/8	15												
203		17												
203-11	11/16	17												
UCFT204		20												
204-12	3/4	20		89.7	14.3	11	25	10.5	60	31	12.7	32.6	M8	0.45
UCFT205		25												
205-13	13/16	25												
205-14	7/8	25	124	98.8	15.9	13	27	12.5	70	34.1	14.3	35.6	M10	0.66
205-15	15/16	25												
205-16	1	25												
UCFT206		30												
206-17	1-1/16	30												
206-18	1-1/8	30	141	116.7	17.9	13	30	12.5	83	38.1	15.9	40.1	M10	0.86
206-19	1-3/16	30												
206-20	1-1/4	30												
UCFT207		35												
207-20	1-1/4	35												
207-21	1-5/8	35	156	130.2	19.1	14	34	14	95	42.9	17.5	44.5	M12	1.31
207-22	1-3/8	35												
207-23	1-7/16	35												
UCFT208		40												
208-24	1-1/2	40	171	143.7	21	14	38	14	105	49.2	19	51.2	M12	1.53
208-25	1-9/16	40												
UCFT209		45												
209-26	1-5/8	45	179	148.4	21.8	14	40	16	111	49.2	19	52	M14	1.73
209-27	1-11/16	45												
209-28	1-3/4	45												
UCFT210		50												
210-29	1-13/16	50	189	157.2	22.2	14	40	16	116	51.6	19	54.8	M14	2.28
210-30	1-7/8	50												
210-31	1-15/16	50												
210-32	2	50												
UCFT211		55												
211-32	2	55	216	184.2	25.4	21	44	18	133	55.6	22.2	58.8	M16	2.72
211-33	2-1/16	55												
211-34	2-1/8	55												
211-35	2-3/16	55												

BEARINGS

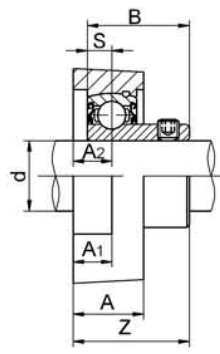
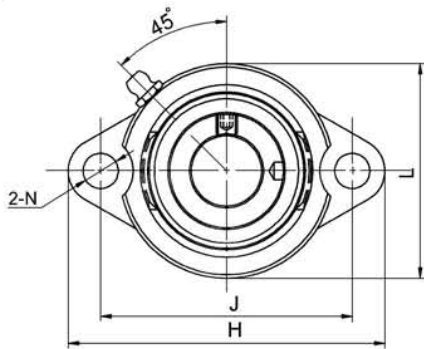

SBLF200

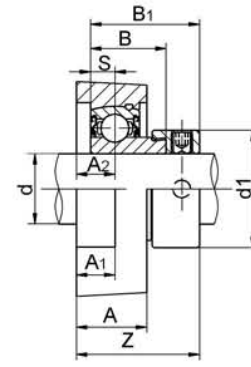

SALF200

SBLF200 Series

Unit No.	Shaft Dia		Dimensions(mm)										Bolt Size (mm)	Weight (kg)
	d		H	J	A ₂	A ₁	A	N	L	B	S	Z		
	(in)	(mm)												
SBLF201 201-8	1/2	12	81	63.5	9.5	9.5	18.0	8	56	22	6.0	25.5	M6	0.27
SBLF202 202-9 202-10	9/16 5/8	15	81	63.5	9.5	9.5	18.0	8	56	22	6.0	25.5	M6	0.25
SBLF203 203-11	11/16	17	81	63.5	9.5	9.5	18.0	8	56	22	6.0	25.5	M6	0.25
SBLF204 204-12	3/4	20	90	71.5	11.0	11.0	20.0	10	61	25	7.0	29.0	M8	0.33
SBLF205 205-14 205-15 205-16	7/8 15/16 1	25	95	76.0	11.0	11.0	20.0	10	64	27	7.5	30.5	M8	0.38
SBLF206 206-17 206-18 206-19 206-20	1-11/16 1-1/8 1-3/16 1-1/4	30	113	90.5	12.0	12.0	22.5	12	76	30	8.0	34.0	M10	0.56
SBLF207 207-20 207-21 207-22 207-23	1-1/4 1-5/16 1-3/8 1-7/16	35	122	100	13	13.0	24	12	89	32	8.5	36.5	M10	0.8
SBLF208 208-24 208-25	1-1/2 1-9/16	40	150	119	13.5	13.0	25	14	106	34	9	38.5	M12	

SALF200 Series

Unit No.	Shaft Dia		Dimensions(mm)											Bolt Size (mm)	Weight (kg)	
	d		H	J	A ₂	A ₁	A	N	L	B ₁	B	S	Z			d ₁
	(in)	(mm)														
SALF201 201-8	1/2	12	81	63.5	9.5	9.5	18.0	8	56	28.6	19.1	6.0	32.1	28.6	M6	0.28
SALF202 202-9 202-10	9/16 5/8	15	81	63.5	9.5	9.5	18.0	8	56	28.6	19.1	6.0	32.1	28.6	M6	0.28
SALF203 203-11	11/16	17	81	63.5	9.5	9.5	18.0	8	56	28.6	19.1	6.0	32.1	28.6	M6	0.28
SALF204 204-12	3/4	20	90	71.5	11.0	11.0	20.0	10	61	31	21.5	7.0	35	33.3	M8	0.33
SALF205 205-14 205-15 205-16	7/8 15/16 1	25	95	76.0	11.0	11.0	20.0	10	64	31.5	22	7.5	35	38.1	M8	0.42
SALF206 206-17 206-18 206-19 206-20	1-11/16 1-1/8 1-3/16 1-1/4	30	113	90.5	12.0	12.0	22.5	12	76	35.7	23.8	8.0	39.7	44.5	M10	0.6
SALF207 207-20 207-21 207-22 207-23	1-1/4 1-5/16 1-3/8 1-7/16	35	122	100	13.0	13.0	24.0	12	89	38.9	25.4	8.5	43.4	55.6	M10	0.85
SALF208 208-24 208-25	1-1/2 1-9/16	40	150	119	13.5	13	25	14	106	43.7	30.2	9	48.2	60.3	M12	

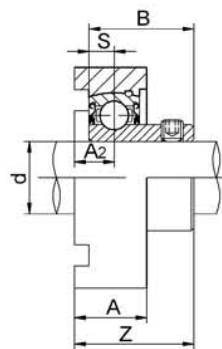
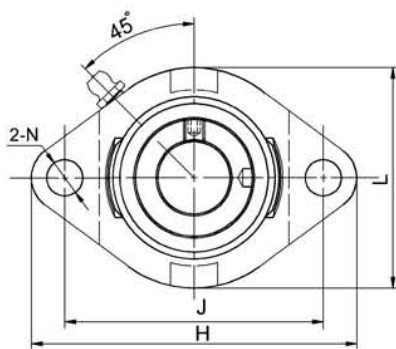

SBFW200

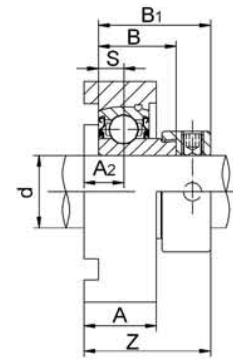

SAFW200

SBFW200 Series

Unit No.	Shaft Dia		Dimensions(mm)									Bolt Size (mm)	Weight (kg)
	d		H	J	A ₂	A	N	L	B	S	Z		
	(in)	(mm)											
SBFW 201 201-8	1/2	12	81	63.5	8.5	15	7	59	22	6	24.5	M6	0.28
SBFW 202 202-9 202-10	9/16 5/8	15	81	63.5	8.5	15	7	59	22	6	24.5	M6	0.27
SBFW 203 203-11	11/16	17	81	63.5	8.5	15	7	59	22	6	24.5	M6	0.26
SBFW 204 204-12	3/4	20	90	71	9.5	17	9	67	25	7	27.5	M8	0.37
SBFW 205 205-14 205-15 205-16	7/8 15/16 1	25	95	76	9.5	17.5	9	71	27	7.5	29	M8	0.44
SBFW 206 206-17 206-18 206-19 206-20	1-1/16 1-1/8 1-3/16 1-1/4	30	113	90	12	20.5	12	84	30	8	34	M10	0.7
SBFW 207 207-20 207-21 207-22 207-23	1-1/4 1-5/16 1-3/8 1-7/16	35	125	100	12.5	22	11.5	93	32	8.5	36	M10	0.91
SBFW 208 208-24 208-25	1-1/2 1-9/16	40	148	119	14.5	25	13.5	103	34	9	39.9	M12	1.2

SAFW200 Series

Unit No.	Shaft Dia		Dimensions(mm)									Bolt Size (mm)	Weight (kg)	
	d		H	J	A ₂	A	N	L	B ₁	B	S			Z
	(in)	(mm)												
SAFW 201 201-8	1/2	12	81	63.5	8.5	15	7	59	28.6	19.1	6	31.1	M6	0.28
SAFW 202 202-9 202-10	9/16 5/8	15	81	63.5	8.5	15	7	59	28.6	19.1	6	31.1	M6	0.27
SAFW 203 203-11	11/16	17	81	63.5	8.5	15	7	59	28.6	22	6	31.1	M6	0.26
SAFW 204 204-12	3/4	20	90	71	9.5	17	9	67	31	21.5	7	33.5	M8	0.37
SAFW 205 205-14 205-15 205-16	7/8 15/16 1	25	95	76	9.5	17.5	9	71	31.5	22	7.5	33.5	M8	0.44
SAFW 206 206-17 206-18 206-19 206-20	1-1/16 1-1/8 1-3/16 1-1/4	30	113	90	12	20.5	12	84	35.7	23.8	8.0	39.7	M10	0.7
SAFW 207 207-20 207-21 207-22 207-23	1-1/4 1-5/16 1-3/8 1-7/16	35	125	100	12.5	22	11.5	93	38.9	25.4	8.5	42.9	M10	0.91
SAFW 208 208-24 208-25	1-1/2 1-9/16	40	148	119	14.5	25	13.5	103	43.7	30.2	9	49.2	M12	1.2

BEARINGS

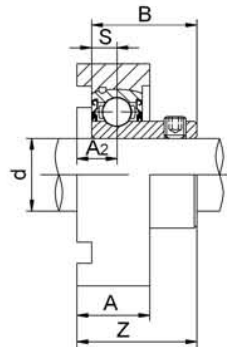
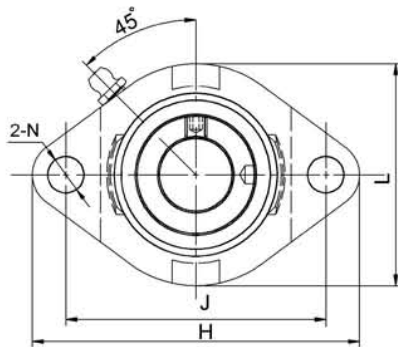

SBFD200

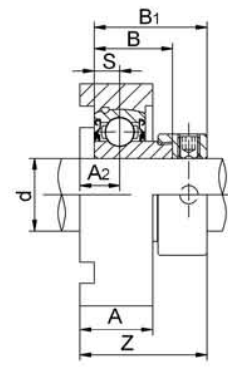

SAFD200

SBFD200 Series

Unit No.	Shaft Dia		Dimensions(mm)									Bolt Size (mm)	Weight (kg)
	d		H	J	A ₂	A	N	L	B	S	Z		
	(in)	(mm)											
SBFD 201 201-8	1/2	12	81	63.5	8.5	15	7	59	22	6	24.5	M6	0.28
SBFD 202 202-9 202-10	9/16 5/8	15	81	63.5	8.5	15	7	59	22	6	24.5	M6	0.27
SBFD 203 203-11	11/16	17	81	63.5	8.5	15	7	59	22	6	24.5	M6	0.26
SBFD 204 204-12	3/4	20	90	71	9.5	17	9	67	25	7	27.5	M8	0.37
SBFD 205 205-14 205-15 205-16	7/8 15/16 1	25	95	76	9.5	17.5	9	71	27	7.5	29	M8	0.44
SBFD 206 206-17 206-18 206-19 206-20	1-1/16 1-1/8 1-3/16 1-1/4	30	113	90	12	20.5	12	84	30	8	34	M10	0.7
SBFD 207 207-20 207-21 207-22 207-23	1-1/4 1-5/16 1-3/8 1-7/16	35	125	100	12.5	22	11.5	93	32	8.5	36	M10	0.91
SBFD 208 208-24 208-25	1-1/2 1-9/16	40	148	119	14.5	25	13.5	103	34	9	39.5	M12	1.2

SAFD200 Series

Unit No.	Shaft Dia		Dimensions(mm)										Bolt Size (mm)	Weight (kg)
	d		H	J	A ₂	A	N	L	B ₁	B	S	Z		
	(in)	(mm)												
SAFD 201 201-8	1/2	12	81	63.5	8.5	15	7	59	28.6	19.1	6	31.1	M6	0.28
SAFD 202 202-9 202-10	9/16 5/8	15	81	63.5	8.5	15	7	59	28.6	19.1	6	31.1	M6	0.27
SAFD 203 203-11	11/16	17	81	63.5	8.5	15	7	59	28.6	19.1	6	31.1	M6	0.26
SAFD 204 204-12	3/4	20	90	71	9.5	17	9	67	31	21.5	7	33.5	M8	0.37
SAFD 205 205-14 205-15 205-16	7/8 15/16 1	25	95	76	9.5	17.5	9	71	31.5	22	7.5	33.5	M8	0.44
SAFD 206 206-17 206-18 206-19 206-20	1-1/16 1-1/8 1-3/16 1-1/4	30	113	90	12	20.5	12	84	35.7	23.8	8	39.7	M10	0.7
SAFD 207 207-20 207-21 207-22 207-23	1-1/4 1-5/16 1-3/8 1-7/16	35	125	100	12.5	22	11.5	93	38.9	25.4	8.5	42.9	M10	0.91
SAFD 208 208-24 208-25	1-1/2 1-9/16	40	148	119	14.5	25	13.5	103	43.7	30.2	9	49.2	M12	1.2

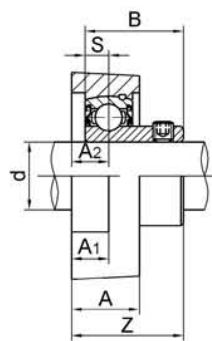
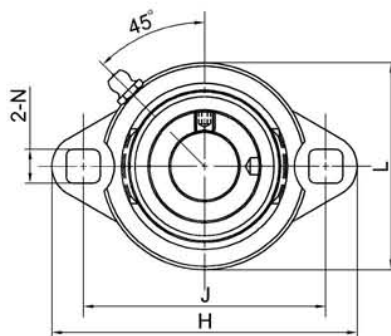

SBPFTD200

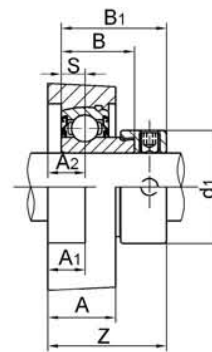

SAPFTD200

SBPFTD200 SAPFTD200 Series

Unit No.	Shaft Dia		Dimensions (mm)										Bolt Size		Weight (kg)	
	d		H	J	L	A ₂	A	A ₁	N	S	B	Z	(mm)	(in)		
	(in)	(mm)														
SBPFTD201		12														
201-8	1/2	12														
202		15	81	63.5	56	9	18	9	8.7	6	22	25	M8	5/16	0.23	
202-10	5/8	15														
203		17														
203-11	11/16	17														
SBPFTD204-12	3/4	20	91	71.5	63	10.2	20	10.2	8.7	7	25	28.2	M8	5/16	0.27	
204		20														
SBPFTD205-14	7/8	25	96	76.2	69	10.5	19	8.7	8.7	7.5	27	28.2	M8	5/16	0.38	
205-15	15/16	25														
205		25														
205-16	1	25														
SBPFTD206-18	1-1/8	30	113	90.5	79	11.5	22	11.5	10.3	8	30	33.5	M10	3/8	0.54	
206		30														
206-19	1-3/16	30														
206-20	1-1/4	30														
SBPFTD207-20	1-1/4	35	122.5	100	89	12.7	23.8	11.8	10.3	8.5	32	35.3	M10	3/8	0.71	
207-21	1-5/16	35														
207-22	1-3/8	35														
207		35														
207-23	1-7/16	35														

Unit No.	Shaft Dia		Dimensions (mm)										Bolt Size		Weight (kg)	
	d		H	J	L	A ₂	A	A ₁	N	S	B	B ₁	Z	(mm)		(in)
	(in)	(mm)														
SAPFTD201		12														
201-8	1/2	12														
202		15	81	63.5	56	9	18	9	8.7	6.5	19.1	28.6	31.1	M8	5/16	0.26
202-10	5/8	15														
203		17														
203-11	11/16	17														
SAPFTD204-12	3/4	20	91	71.5	63	10.2	20	10.2	8.7	7.5	21.5	31	33.6	M8	5/16	0.29
204		20														
SAPFTD205-14	7/8	25	96	76.2	69	10.5	19	8.7	8.7	7.5	22	31.5	32.1	M8	5/16	0.4
205-15	15/16	25														
205		25														
205-16	1	25														
SAPFTD206-18	1-1/8	30	113	90.5	79	11.5	22	11.5	10.3	9	23.8	35.7	38.2	M10	3/8	0.60
206		30														
206-19	1-3/16	30														
206-20	1-1/4	30														
SAPFTD207-20	1-1/4	35	122.5	100	89	12.7	23.8	11.8	10.3	9.5	25.4	38.9	41.2	M10	3/8	0.84
207-21	1-5/16	35														
207-22	1-3/8	35														
207		35														
207-23	1-7/16	35														

BEARINGS

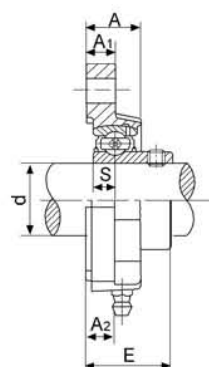
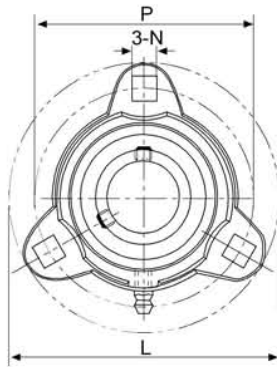

• SBFCT2

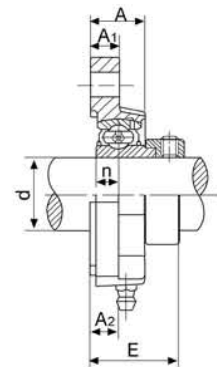

• SAFCT2

SBFCT200 Series

Unit No.	Shaft Dia		Dimensions (mm)								Bolt Size		Bearing NO	Housing NO.	Weight (kg)
	d		L	P	A ₁	A	A ₂	N	S	E					
	(in)	(mm)													
SBFCT201		12													
201-8	1/2	15	81	63.5	10.7	19.1	10.7	7.1	6	26.7	M6	1/4	SB201	FCT203	0.21
202	5/8	17											202-10		
203	11/16	17											203		
203-11	11/16	17											203-11		
SBFCT204-12	3/4	20	90.5	71.4	11.1	19.8	11.1	8.7	7	29.1	M8	5/16	SB204-12	FCT204	0.32
204	20												204		
SBFCT205-14	7/8		95.2	76.2	10.3	19.8	10.3	8.7	7.5	29.8	M8	5/16	SB205-14	FCT205	0.36
205-15	15/16	25											205-15		
205	1	25											205		
205-16	1	25											205-16		
SBFCT206-18	1-1/8		113	90.5	12	22	12	10.3	8	34	M10	3/8	SB206-18	FCT206	0.57
206	30	206													
206-19	1-3/16	30											206-19		
206-20	1-1/4	30											206-20		
SBFCT207-20	1-1/4		122.5	100	12.7	23.8	12.7	10.3	8.5	36.2	M10	3/8	SB207-20	FCT207	0.71
207-21	1-5/16	35											207-21		
207-22	1-3/8	35											207-22		
207	1-3/8	35											207		
207-23	1-7/16	35											207-23		

SAFCT200 Series

Unit No.	Shaft Dia		Dimensions (mm)								Bolt Size		Bearing NO	Housing NO.	Weight (kg)
	d		L	P	A ₁	A	A ₂	S	n	E					
	(in)	(mm)													
SAFCT201		12													
201-8	1/2	15	81	63.5	10.7	19.1	10.7	7.1	6.5	32.8	M6	1/4	SA201	FCT203	0.26
202	5/8	17											202-10		
203	11/16	17											203		
203-11	11/16	17											203-11		
SAFCT204-12	3/4	20	90.5	71.4	11.1	19.8	11.1	8.7	7.5	34.5	M8	5/16	SA204-12	FCT204	0.34
204	20												204		
SAFCT205-14	7/8		95.2	76.2	10.3	19.8	10.3	8.7	7.5	33.7	M8	5/16	SA205-14	FCT205	0.39
205-15	15/16	25											205-15		
205	1	25											205		
205-16	1	25											205-16		
SAFCT206-18	1-1/8		113	90.5	12	22	12	10.3	9	38.7	M10	3/8	SA206-18	FCT206	0.61
206	30	206													
206-19	1-3/16	30											206-19		
206-20	1-1/4	30											206-20		
SAFCT207-20	1-1/4		122.5	100	12.7	23.8	12.7	10.3	9.5	42.1	M10	3/8	SA207-20	FCT207	0.82
207-21	1-5/16	35											207-21		
207-22	1-3/8	35											207-22		
207	1-3/8	35											207		
207-23	1-7/16	35											207-23		

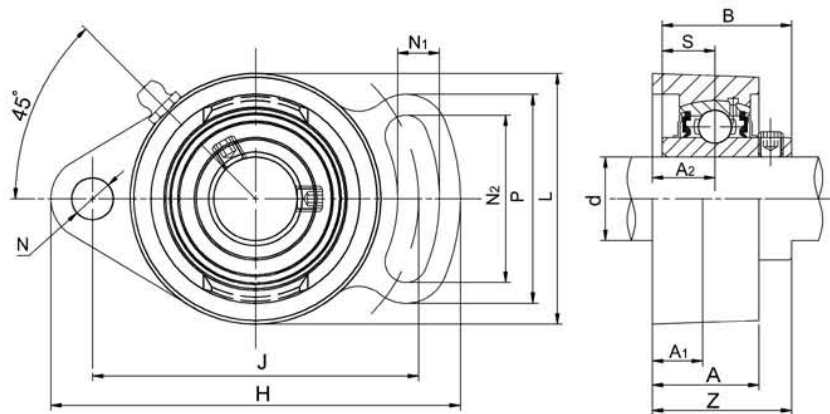

UCFA200 Series

Unit No.	Shaft Dia		Dimensions(mm)													Bolt Size (mm)	Weight (kg)
	d (in)	d (mm)	H	J	A ₂	A ₁	A	N	N ₁	N ₂	L	P	B	S	Z		
UCFA201 201-8	1/2	12	98	78	15	12	25.5	10	10	40	60	50	31	12.7	33.3	M8	0.53
UCFA202 202-9 202-10	9/16 5/8	15	98	78	15	12	25.5	10	10	40	60	50	31	12.7	33.3	M8	0.49
UCFA203 203-11	11/16	17	98	78	15	12	25.5	10	10	40	60	50	31	12.7	33.3	M8	0.48
UCFA204 204-12	3/4	20	98	78	15	12	25.5	10	10	40	60	50	31	12.7	33.3	M8	0.46
UCFA205 205-14 205-15 205-16	7/8 15/16 1	25	125	98	16	14	27	12	13	51	70	65	34.1	14.3	35.8	M10	0.69
UCFA206 206-17 206-18 206-19 206-20	1-1/16 1-1/8 1-3/16 1-1/4	30	142	117	18	14	31	12	13	58	83	72	38.1	15.9	40.2	M10	1.00
UCFA207 207-20 207-21 207-22 207-23	1-1/4 1-5/16 1-3/8 1-7/16	35	154	130	19	16	34	15	15	66	95	82	42.9	17.5	44.4	M12	1.50
UCFA208 208-24 208-25	1-1/2 1-9/16	40	172	144	21	16	38	15	15	71	105	87	49.2	19.0	51.2	M12	1.80
UCFA209 209-26 209-27 209-28	1-5/8 1-11/16 1-3/4	45	180	148	22	18	40	15	15	72	110	90	49.2	19.0	52.2	M14	2.10
UCFA210 210-30 210-31 210-32	1-7/8 1-15/16 2	50	190	157	22	18	40	15	15	76	115	94	51.6	19.0	54.6	M14	2.30
UCFA211 211-32 211-34 211-35	2 2-1/8 2-3/16	55	216	184	25	20	43	16	17	86	132	104	55.6	22.2	58.4	M14	3.60

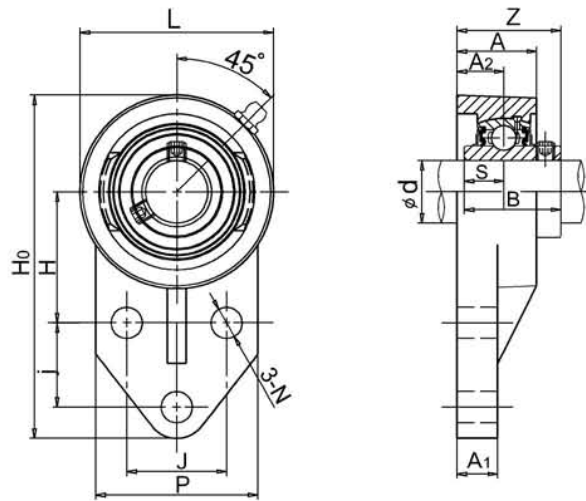

UCFB200 Series

Unit No.	Shaft Dia		Dimensions(mm)													Bolt Size (mm)	Weight (kg)
	d		H ₀	H	J	j	A ₂	A ₁	A	N	L	P	B	S	Z		
	(in)	(mm)															
UCFB201		12	110	42	32	27	15	13	25.5	10	62	52	31	12.7	33.3	M8	0.62
UCFB201-8	1/2																
UCFB202		15	110	42	32	27	15	13	25.5	10	62	52	31	12.7	33.3	M8	0.58
UCFB202-9	9/16																
UCFB202-10	5/8																
UCFB203		17	110	42	32	27	15	13	25.5	10	60	52	31	12.7	33.3	M8	0.57
UCFB203-11	11/16																
UCFB204		20	110	42	32	27	15	13	25.5	10	62	52	31	12.7	33.3	M8	0.62
UCFB204-12	3/4																
UCFB205		25	116	45	34	27	16	13	27	10	68	56	34.1	14.3	35.7	M8	0.69
UCFB205-14	7/8																
UCFB205-15	15/16																
UCFB205-16	1																
UCFB206		30	130	50	40	29	18	13	31	10	79	65	38.1	15.9	40.2	M8	0.93
UCFB206-17	1-1/16																
UCFB206-18	1-1/8																
UCFB206-19	1-3/16																
UCFB206-20	1-1/4																
UCFB207		35	144	55	46	32	19	15	34	10	90	70	42.9	17.5	44.4	M8	1.30
UCFB207-20	1-1/4																
UCFB207-21	1-5/16																
UCFB207-22	1-3/8																
UCFB207-23	1-7/16																
UCFB208		40	164	60	50	41	21	16	36	12	100	78	49.2	19.0	51.2	M10	1.80
UCFB208-24	1-1/2																
UCFB208-25	1-9/16																
UCFB209		45	174	65	54	43	22	18	38	12	106	80	49.2	19.0	52.2	M10	2.00
UCFB209-26	1-5/8																
UCFB209-27	1-11/16																
UCFB209-28	1-3/4																
UCFB210		50	184	68	58	46	22	18	40	12	112	86	51.6	19.0	54.6	M10	2.30
UCFB210-30	1-7/8																
UCFB210-31	1-15/16																
UCFB210-32	2																

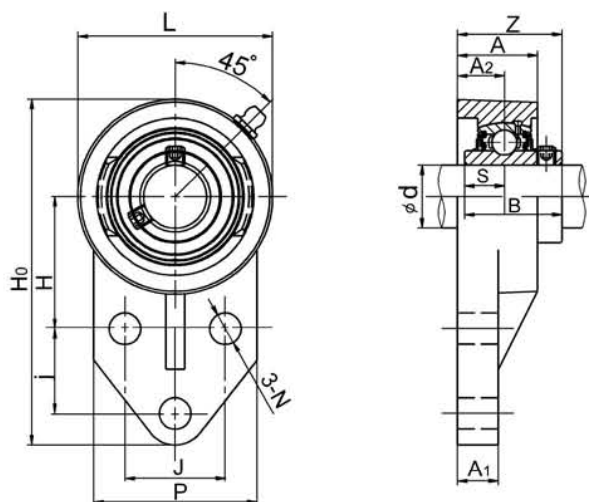

UCFB200A Series

Unit No.	Shaft Dia		Dimensions(mm)													Bolt Size (mm)	Weight (kg)	
	d		H ₀	H	J	j	A ₂	A ₁	A	N	L	P	B	S	Z			
	(in)	(mm)																
UCFB201A	1/2	12	107.95	42.86	38.1	22.22	15.88	7.94	25.4	9.92	63.5	60.33	31	12.7	34.18	M8	0.62	
UCFB201-8A																		
UCFB202A	9/16	15	107.95	42.86	38.1	22.22	15.88	7.94	25.4	9.92	63.5	60.33	31	12.7	34.18	M8	0.58	
UCFB202-9A																		
UCFB202-10A	5/8																	
UCFB203A	11/16	17	107.95	42.86	38.1	22.22	15.88	7.94	25.4	9.92	63.5	60.33	31	12.7	34.18	M8	0.57	
UCFB203-11A																		
UCFB204A	3/4	20	107.95	42.86	38.1	22.22	15.88	7.94	25.4	9.92	63.5	60.33	31	12.7	34.18	M8	0.62	
UCFB204-12A																		
UCFB205A	7/8	25	120.65	46.04	41.27	28.58	17.07	9.53	28.57	9.92	69.85	63.5	34.1	14.3	36.87	M8	0.69	
UCFB205-14A																		
UCFB205-15A		15/16																
UCFB205-16A		1																
UCFB206A	1-1/16	30	136.53	52.39	47.63	31.75	18.65	12.7	31.75	9.92	82.55	69.85	38.1	15.9	40.85	M8	0.93	
UCFB206-17A																		
UCFB206-18A		1-1/8																
UCFB206-19A		1-3/16																
UCFB206-20A	1-1/4																	
UCFB207A	1-1/4	35	155.58	60.33	50.8	31.75	21.03	12.7	36.51	13.1	95.25	82.55	42.9	17.5	46.43	M8	1.30	
UCFB207-20A																		
UCFB207-21A		1-5/16																
UCFB207-22A		1-3/8																
UCFB207-23A	1-7/16																	
UCFB208A	1-1/2	40	164.31	60.33	50.01	41.27	21.03	15.88	35.72	11.91	100.01	77.79	49.2	19	51.23	M10	1.80	
UCFB208-24A																		
UCFB208-25A		1-9/16																

BEARINGS

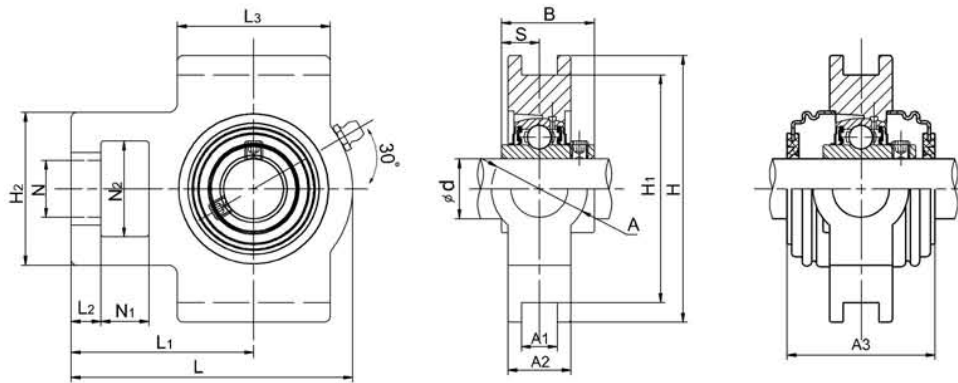

UCT200 Series

Unit No.	Shaft Dia		Dimensions(mm)														Weight (kg)		
	d		N ₁	L ₂	H ₂	N ₂	N	L ₃	A ₁	H ₁	H	L	A	A ₂	L ₁	B		S	A ₃
	(in)	(mm)																	
UCWT201 202 203		12 15 17	15	9	46	31	18	46	12	70	82	88	30	21	58	27.4	11.5		
UCT201 201-8	1/2	12	16	10	51	32	19	51	12	76	89	94	32	21	61	31	12.7	0.80	
UCT202 202-9 202-10	9/16 5/8	15	16	10	51	32	19	51	12	76	89	94	32	21	61	31	12.7	0.79	
UCT203 203-11	11/16	17	16	10	51	32	19	51	12	76	89	94	32	21	61	31	12.7	0.78	
UCT204 204-12	3/4	20	16	10	51	32	19	51	12	76	89	94	32	21	61	31	12.7	46.4	0.72
UCT205 205-14 205-15 205-16	7/8 15/16 1	25	16	10	51	32	19	51	12	76	89	97	32	24	62	34.1	14.3	48	0.8
UCT206 206-17 206-18 206-19 206-20	1-1/16 1-1/8 1-3/16 1-1/4	30	16	10	56	37	22	57	12	89	102	113	37	28	70	38.1	15.9	23	1.26
UCT207 207-20 207-21 207-22 207-23	1-1/4 1-5/16 1-3/8 1-7/16	35	16	13	64	37	22	64	12	89	102	129	37	30	78	42.9	17.5	59	1.68
UCT208 208-24 208-25	1-1/2 1-9/16	40	19	16	83	49	29	83	16	102	114	144	49	33	88	49.2	19	68.2	2.28
UCT209 209-26 209-27 209-28	1-5/8 1-11/16 1-3/4	45	19	16	83	49	29	83	16	102	117	144	49	35	87	49.2	19	70	2.52
UCT210 210-30 210-31 210-32	1-7/8 1-15/16 2	50	19	16	83	49	29	86	16	102	117	149	49	37	90	51.6	19	76	2.75
UCT211 211-32 211-34 211-35	2 2-1/8 2-3/16	55	25	19	102	64	35	95	22	130	146	171	64	38	106	55.6	22.2	76	4.1
UCT212 212-36 212-38 212-39	2-1/4 2-3/8 2-7/16	60	32	19	102	64	35	102	22	130	146	194	64	42	119	65.1	25.4	89	4.9
UCT213 213-40	2-1/2	65	32	21	111	70	41	121	26	151	167	224	70	44	137	65.1	25.4	89	6.7
UCT214 214-44	2-3/4	70	32	21	111	70	41	121	26	151	167	224	70	46	137	74.6	30.2	98	6.9
UCT215 215-47 215-48	2-15/16 3	75	32	21	111	70	41	121	26	151	167	232	70	48	140	77.8	33.3	97	7.4
UCT216		80	32	21	111	70	41	121	26	165	184	235	70	51	140	82.6	33.3	110	8.1
UCT217 217-52	3-1/4	85	38	29	124	73	48	157	30	173	198	260	73	54	162	85.7	34.1	114.2	11
UCT218 218-56	3-1/4	90	40	40	130	80	48	140	30	190	215	275	80	55	170	96	39.7		12.2

NOTE: 1 Open / Close (S/SM) covers are optional

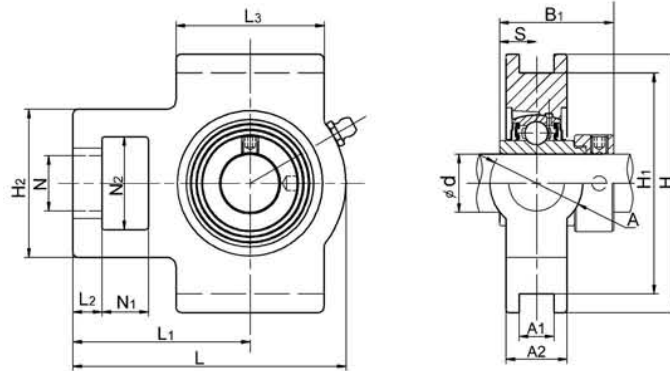

NAT200 Series

Unit No.	Shaft Dia		Dimensions (mm)														Weight (kg)	
	d		N1	L2	H2	N2	N	L3	A1	H1	H	L	A	A2	L1	B1		S
	(in)	(mm)																
NAT201S		12																
201-8S	1/2	12																
202S		15	15	9	46	31	18	46	12	70	82	88	30	21	58	37.3	13.9	0.78
202-10S	5/8	15																
203S		17																
203-11S	11/16	17																
NAT201		12																
201-8	1/2	12																
202		15																
202-10	5/8	15	16	10	51	32	19	51	12	76	89	94	32	21	61	43.5	17	0.87
203		17																
203-11	11/16	17																
204		20																
204-12	3/4	20																
NAT205		25																
205-14	7/8	25	16	10	51	32	19	51	12	76	89	97	32	24	62	44.3	17.4	0.92
205-15	15/16	25																
205-16	1	25																
NAT206		30																
206-18	1-1/8	30	16	10	56	37	22	57	12	89	102	113	37	28	70	48.3	18.2	1.39
206-19	1-3/16	30																
206-20	1-1/4	30																
NAT207		35																
207-20	1-1/4	35																
207-21	1-5/16	35	16	13	64	37	22	64	12	89	102	129	37	30	78	51.1	18.8	1.83
207-22	1-3/8	35																
207-23	1-7/16	35																
NAT208		40																
208-24	1-1/2	40	19	16	83	49	29	83	16	102	114	144	49	33	88	56.3	21.4	2.64
208-25	1-9/16	40																
NAT209		45																
209-26	1-5/8	45	19	16	83	49	29	83	16	102	117	144	49	35	87	56.3	21.4	2.67
209-27	1-1/16	45																
209-28	1-3/4	45																
NAT210		50																
210-30	1-7/8	50	19	16	83	49	29	86	16	102	117	149	49	37	90	62.7	24.6	2.81
210-31	1-15/16	50																
NAT211		55																
211-32	2	55	25	19	102	64	35	95	22	130	146	171	64	38	106	71.3	27.7	4.27
211-34	2-1/8	55																
211-35	2-3/16	55																
NAT212		60																
212-36	2-1/4	60	32	19	102	64	35	102	22	130	146	194	64	42	119	77.7	30.9	5.26
212-38	2-3/8	60																
212-39	2-7/16	60																
NAT213		65																
213-40	2-1/2	65	32	21	111	70	41	121	26	151	167	224	70	44	137	85.7	34.1	7.55
NAT214		70																
214-44	2-3/4	70	32	21	111	70	41	121	26	151	167	224	70	46	137	85.7	34.1	7.62
NAT215		75																
215-47	2-15/16	75	32	21	111	70	41	121	26	151	167	232	70	48	140	92.1	37.3	8.13
215-48	3	75																
NAT216		80																
216-52	3-1/4	80	38	29	124	73	48	157	30	173	198	260	73	54	162	73.2	23.4	8.53
NAT217		85																
217-52	3-1/4	85																

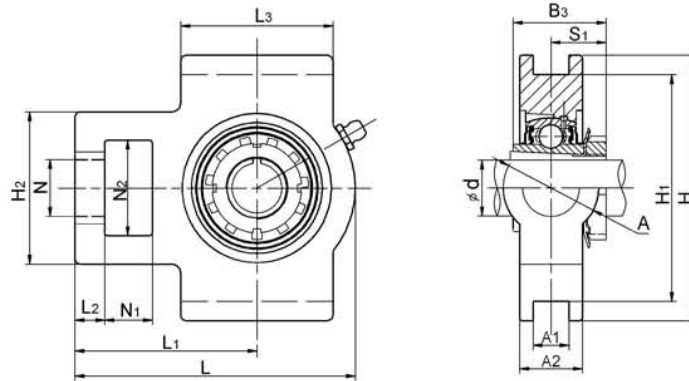

UKT200+H Series

Unit No.	Shaft Dia		Dimensions (mm)														Weight (kg)	
	d		N ₁	L ₂	H ₂	N ₂	N	L ₃	A ₁	H ₁	H	L	A	A ₂	L ₁	B ₃		S ₁
	(in)	(mm)																
UKT205+H2305 205+HE2305	3/4	20	16	10	51	32	19	51	12	76	89	97	32	24	62	35	18.5	0.8
UKT206+H2306 206+HS2306 206+HE2306	7/8 1	25	16	10	56	37	22	57	12	89	102	113	37	28	70	38	20.5	1.26
UKT207+H2307 207+HS2307	1-1/8	30	16	13	64	37	22	64	12	89	102	129	37	30	78	43	22.5	1.68
UKT208+H2308 208+HE2308 208+HS2308	1-1/4 1-3/8	35	19	16	83	49	29	83	16	102	114	144	49	33	88	46	24.5	2.28
UKT209+H2309 209+HA2309 209+HE2309 209+HS2309	1-7/16 1-1/2 1-5/8	40	19	16	83	49	29	83	16	102	117	144	49	35	87	50	26	2.52
UKT210+H2310 210+HS2310 210+HA2310 210+HE2310	1-5/8 1-11/16 1-3/4	45	19	16	83	49	29	86	16	102	117	149	49	37	90	55	27.5	2.75
UKT211+H2311 211+HS2311 211+HA2311 211+HE2311	1-7/8 1-15/16 2	50	25	19	102	64	35	95	22	130	146	171	64	38	106	59	28.5	4.1
UKT212+H2312 212+HS2312	2-1/8	55	32	19	102	64	35	102	22	130	146	194	64	42	119	62	31	4.9
UKT213+H2313 213+HA2313 213+HE2313 213+HS2313	2-3/16 2-1/4 2-3/8	60	32	21	111	70	41	121	26	151	167	224	70	44	137	65	32	6.7
UKT215+H2315 215+HA2315 215+HE2315	2-7/16 2-1/2	65	32	21	111	70	41	121	26	151	167	232	70	48	140	73	35.5	7.4
UKT216+H2316 216+HA2316 216+HE2316	2-11/16 2-3/4	70	32	21	111	70	41	121	26	165	184	235	70	51	140	78	39	8.1
UKT217+H2317 217+HA2317 217+HE2317	2-15/16 3	75	38	29	124	73	48	157	30	173	198	260	73	54	162	82	40	11

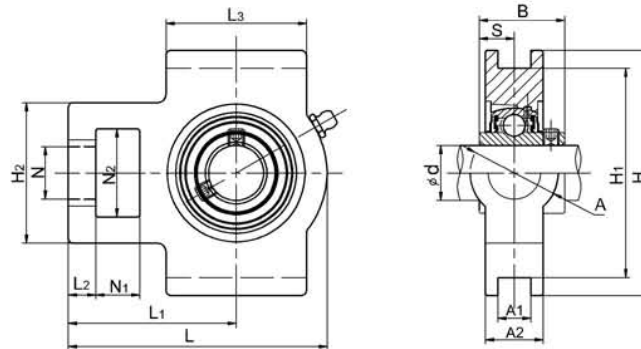

UCTX00 Series

Unit No.	Shaft Dia		Dimensions (mm)														Weight (kg)		
	d		N ₁	L ₂	H ₂	N ₂	N	L ₃	A ₁	H ₁	H	L	A	A ₂	L ₁	B		S	
	(in)	(mm)																	
UCTX05		25																	
05-13	13/16																		
05-14	7/8		16	12	56	37	22	57	12	89	102	113	37	28	70	38.1	15.9	1.4	
05-15	15/16																		
05-16	1																		
UCTX06		30																	
06-17	1-1/16																		
06-18	1-1/8		16	15	64	37	22	64	12	89	102	129	37	30	78	42.9	17.5	1.8	
06-19	1-3/16																		
06-20	1-1/4																		
UCTX07		35																	
07-21	1-5/16																		
07-22	1-3/8		19	17	83	49	29	83	16	102	114	144	49	36	88	49.2	19	2.6	
07-23	1-7/16																		
UCTX08		40																	
08-24	1-1/2																		
08-25	1-9/16		19	17	83	49	29	83	16	102	117	144	49	36	87	49.2	19	2.6	
UCTX09		45																	
09-26	1-5/8																		
09-27	1-11/16		19	18	83	49	29	86	16	102	117	151	49	38	92	51.6	19	2.8	
09-28	1-3/4																		
09-29	1-13/16																		
UCTX10		50																	
10-30	1-7/8																		
10-31	1-15/16		25	21	102	64	35	95	22	130	146	171	64	42	106	55.6	22.2	4.3	
10-32	2																		
UCTX11		55																	
11-33	2-1/16																		
11-34	2-1/8																		
11-35	2-3/16		32	21	102	64	35	102	22	130	146	194	64	44	119	65.1	25.4	5.2	
11-36	2-1/4																		
11-37	2-5/16																		
UCTX12		60																	
12-38	2-3/8																		
12-39	2-7/16		32	23	111	70	41	121	26	151	167	224	70	48	137	65	25.4	7.6	
UCTX13		65																	
13-40	2-1/2																		
13-41	2-9/16		32	23	111	70	41	121	26	151	167	224	70	48	137	74.6	30.2	7.6	
UCTX14		70																	
14-42	2-5/8																		
14-43	2-11/16		32	23	111	70	41	121	26	151	167	232	70	48	140	77.8	33.3	7.7	
14-44	2-3/4																		
UCTX15		75																	
15-45	2-13/16																		
15-46	2-7/8																		
15-47	2-15/16		32	23	111	70	41	121	28	165	184	235	70	48	140	82.6	33.3	7.55	
15-48	3																		
UCTX16		80																	
16-49	3-1/16																		
16-50	3-1/8																		
16-51	3-3/16		38	30	124	73	48	157	28	173	198	260	73	54	162	85.7	34.1	11	
16-52	3-1/4																		
UCTX17		85																	
17-53	3-5/16																		
17-55	3-7/16		38	30	124	73	48	157	28	173	198	260	73	54	162	96	39.7	12	

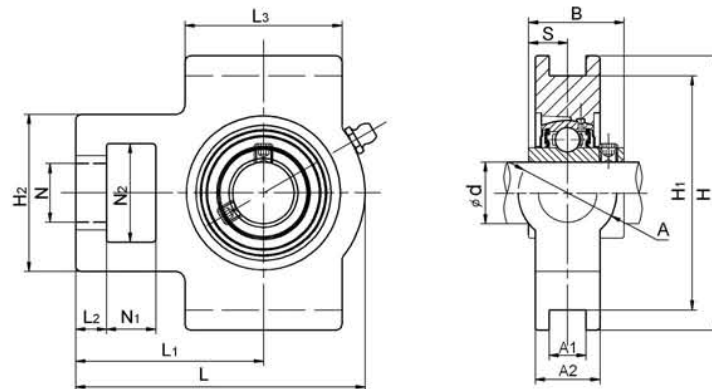

UCT300 Series

Unit No	Shaft Dia d(mm)	Dimensions(mm)															Weight (kg)
		N ₁	L ₂	H ₂	N ₂	N	L ₃	A ₁	H ₁	H	L	A	A ₂	L ₁	B	S	
UCT305	25	16	12	62	36	26	65	12	80	90	122	36	26	76	38	15	1.41
UCT306	30	18	14	70	41	28	74	16	90	100	137	41	28	85	43	17	1.85
UCT307	35	20	15	75	45	30	80	16	100	111	150	45	32	94	48	19	2.45
UCT308	40	22	17	83	50	32	89	18	112	124	162	50	34	100	52	19	3.09
UCT309	45	24	18	90	55	34	97	18	125	138	178	55	38	110	57	22	4.08
UCT310	50	27	20	98	61	37	106	20	140	151	191	61	40	117	61	22	5.25
UCT311	55	29	21	105	66	39	115	22	150	163	207	66	44	127	66	25	6.41
UCT312	60	31	23	115	71	41	123	22	160	179	220	72	46	135	71	26	7.61
UCT313	65	32	25	116	70	43	134	26	170	190	238	80	50	146	75	30	9.22
UCT314	70	36	25	130	85	46	140	26	180	202	252	90	52	155	78	33	11.4
UCT315	75	36	25	134	85	46	150	26	192	216	262	90	55	160	82	32	12.9
UCT316	80	42	28	150	98	53	160	30	204	230	282	102	60	174	86	34	15.65
UCT317	85	42	30	152	98	53	170	32	214	240	298	102	64	183	96	40	19.34
UCT318	90	46	30	160	106	57	175	32	228	255	312	110	66	192	96	40	21.25
UCT319	95	46	31	165	106	57	180	35	240	270	322	110	72	197	103	41	24.4
UCT320	100	48	32	175	115	59	200	35	260	290	345	120	75	210	108	42	30.6
UCT321	105	48	32	175	115	59	200	35	260	290	345	120	75	210	112	44	30.2
UCT322	110	52	38	185	125	65	215	38	285	320	385	130	80	235	117	46	38.8
UCT324	120	60	42	210	140	70	230	45	320	355	432	140	90	267	126	51	54.6
UCT326	130	65	45	220	150	75	240	50	350	385	465	150	100	285	135	54	68.4
UCT328	140	70	50	230	160	80	255	50	380	415	515	155	100	315	145	59	83.2

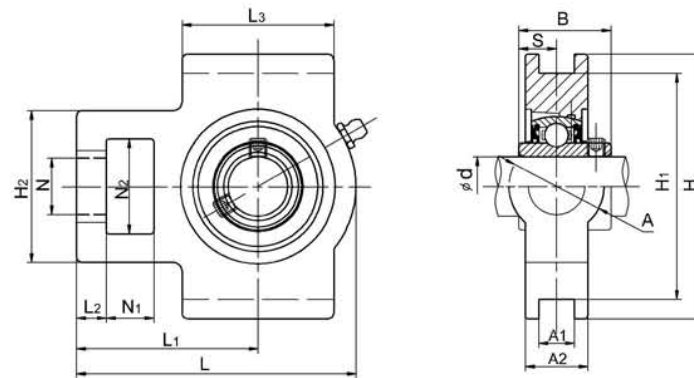

UCST200 Series

Unit No.	Shaft Dia		Dimensions (mm)														Weight (kg)	
	d		N1	L2	H2	N2	N	L3	A1	H1	H	L	A	A2	L1	B		S
	(in)	(mm)																
UCST201		12																
201-8	1/2																	
202		15																
202-10	5/8		16	10	51	32	19	51	13.5	76	89	94	32	21	61	31	12.7	0.8
203		17																
203-11	11/16																	
204		20																
204-12	3/4																	
UCST205		25																
205-14	7/8		16	10	51	32	19	51	13.5	76	89	97	32	24	62	34.1	14.3	0.8
205-15	15/16																	
205-16	1																	
UCST206		30																
206-17	1-1/16		16	10	56	37	22	57	13.5	89	102	113	37	28	70	38.1	15.9	1.26
206-18	1-1/8																	
206-19	1-3/16																	
206-20	1-1/4																	
UCST207		35																
207-20	1-1/4		16	13	64	37	22	64	13.5	89	102	129	37	30	78	42.9	17.5	1.68
207-21	1-5/16																	
207-22	1-3/8																	
207-23	1-7/16																	
UCST208		40																
208-24	1-1/2		19	16	83	49	29	83	17.5	102	114	144	49	33	88	49.2	19	2.28
208-25	1-9/16																	
UCST209		45																
209-26	1-5/8		19	16	83	49	29	83	17.5	102	117	144	49	35	87	49.2	19	2.52
209-27	1-11/16																	
209-28	1-3/4																	
UCST210		50																
210-30	1-7/8		19	16	83	49	29	86	17.5	102	117	149	49	37	90	51.6	19	2.75
210-31	1-15/16																	
210-32	2																	
UCST211		55																
211-32	2		25	19	102	64	35	95	27	130	146	171	64	38	106	55.6	22.2	4.1
211-34	2-1/8																	
211-35	2-3/16																	
UCST212		60																
212-36	2-1/4		32	19	102	64	35	102	27	130	146	194	64	42	119	65.1	25.4	4.9
212-38	2-3/8																	
212-39	2-7/16																	

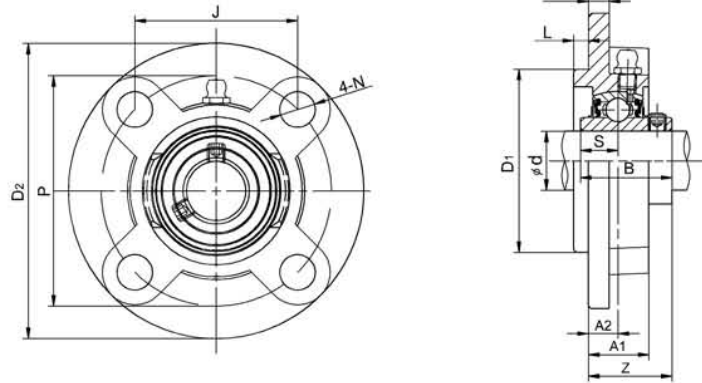

UCFC200 Series

Unit No.	Shaft Dia		Dimensions(mm)												Bolt Size (mm)	Weight (kg)
	d		D ₂	P	J	A ₂	N	L	H ₁	A ₁	D ₁	B	S	Z		
	(in)	(mm)														
UCWFC201 201-8	1/2	12	90	70	49.5	10	10	4	5	19	55	27.4	11.5	25.9	M8	0.64
UCWFC202 202-9 202-10	9/16 5/8	15	90	70	49.5	10	10	4	5	19	55	27.4	11.5	25.9	M8	0.60
UCWFC203 203-11	11/16	17	90	70	49.5	10	10	4	5	19	55	27.4	11.5	25.9	M8	0.58
UCFC204 204-12	3/4	20	100	78	55.1	10	12	5	7	20.5	62	31	12.7	28.3	M10	0.75
UCFC 205 205-14 205-15 205-16	7/8 15/16 1	25	115	90	63.6	10	12	6	7	21	70	34.1	14.3	29.8	M10	1.00
UCFC206 206-17 206-18 206-19 206-20	1-1/16 1-1/8 1-3/16 1-1/4	30	125	100	70.7	10	12	8	8	23	80	38.1	15.9	32.2	M10	1.30
UCFC207 207-20 207-21 207-22 207-23	1-1/4 1-5/16 1-3/8 1-7/16	35	135	110	77.8	11	14	8	9	26	90	42.9	17.5	36.4	M12	1.75
UCFC208 208-24 208-25	1-1/2 1-9/16	40	145	120	84.8	11	14	10	9	26	100	49.2	19	41.2	M12	2.00
UCFC209 209-26 209-27 209-28	1-5/8 1-11/16 1-3/4	45	160	132	93.3	10	16	12	14	26	105	49.2	19	40.2	M14	2.50
UCFC210 210-30 210-31 210-32	1-7/8 1-15/16 2	50	165	138	97.6	10	16	12	14	28	110	51.6	19	42.6	M14	2.95
UCFC211 211-32 211-34 211-35	2 2-1/8 2-3/16	55	185	150	106.1	13	19	12	15	30	125	55.6	22.2	46.4	M16	4.00
UCFC212 212-36 212-38 212-39	2-1/4 2-3/8 2-7/16	60	195	160	113.1	17	19	12	15	35	135	65.1	25.4	56.7	M16	4.90
UCFC213 213-40	2-1/2	65	205	170	120.2	16	19	14	15	36	145	65.1	25.4	55.7	M16	5.35
UCFC214 214-44	2-3/4	70	215	177	125.1	17	19	14	18	38	150	74.6	30.2	61.4	M16	6.90
UCFC215 215-47 215-48	2-15/16 3	75	220	184	130.1	18	19	16	18	39	160	77.8	33.3	62.5	M16	7.50
UCFC216		80	240	200	141.4	18	23	16	18	42	170	82.6	33.3	67.3	M20	8.70
UCFC217 217-52	3-1/4	85	250	208	147.1	18	23	18	20	45	180	85.7	34.1	69.6	M20	10.30
UCFC218 218-56	3-1/2	90	265	220	155.5	22	23	18	20	50	190	96	39.7	78.3	M20	13.50

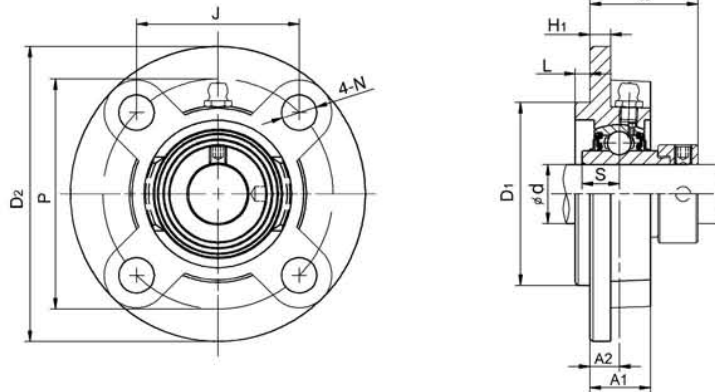

NAFC200 Series

Unit No.	Shaft Dia		Dimensions (mm)										Bolt Size (mm)	Weight (kg)	
	d		D ₂	P	J	A ₂	N	L	H ₁	A ₁	D ₁	S			Z
	(in)	(mm)													
NAFC201S		12													
201-8S	1/2	12													
202S		15	90	70	49.5	10	10	4	5	19	55	13.9	33.4	M8	0.6
202-10S	5/8	15													
203S		17													
203-11S	11/16	17													
NAFC 201		12													
201-8	1/2	12													
202		15													
202-10	5/8	15	100	78	55.1	10	12	5	7	20.5	62	17.1	36.5	M10	0.83
203		17													
203-11	11/16	17													
204		20													
204-12	3/4	20													
NAFC 205		25													
205-14	7/8	25	115	90	63.6	10	12	6	7	21	70	17.5	36.9	M10	1.0
205-15	15/16	25													
205-16	1	25													
NAFC 206		30													
206-18	1-1/8	30	125	100	70.7	10	12	8	8	23	80	18.3	40.1	M10	1.5
206-19	1-3/16	30													
206-20	1-1/4	30													
NAFC 207		35													
207-20	1-1/4	35	135	110	77.8	11	14	8	9	26	90	18.8	43.3	M12	1.8
207-21	1-5/16	35													
207-22	1-3/8	35													
207-23	1-7/16	35													
NAFC 208		40													
208-24	1-1/2	40	145	120	84.8	11	14	10	9	26	100	21.4	45.9	M12	2.2
208-25	1-9/16	40													
NAFC 209		45													
209-26	1-5/8	45	160	132	93.3	10	16	12	14	26	105	21.4	44.9	M14	2.8
209-27	1-11/16	45													
209-28	1-3/4	45													
NAFC 210		50													
210-30	1-7/8	50	165	138	97.6	10	16	12	14	28	110	24.6	48.1	M14	3.3
210-31	1-15/16	50													
NAFC 211		55													
211-32	2	55	185	150	106.1	13	19	12	15	30	125	27.8	56.6	M16	4.5
211-34	2-1/8	55													
211-35	2-3/16	55													
NAFC 212		60													
212-36	2-1/4	60	195	160	113.1	17	19	12	15	35	135	31	63.8	M16	5.7
212-38	2-3/8	60													
212-39	2-7/16	60													
NAFC 213		65													
213-40	2-1/2	65	205	170	120.2	16	19	14	15	36	145	34.3	67.6	M16	6.5
NAFC 214		70													
214-44	2-3/4	70	215	177	125.1	17	19	14	18	38	150	34.3	68.6	M16	7.2
NAFC 215		75													
215-48	3	75	220	184	130.1	18	19	16	18	39	160	37.3	72.8	M16	8

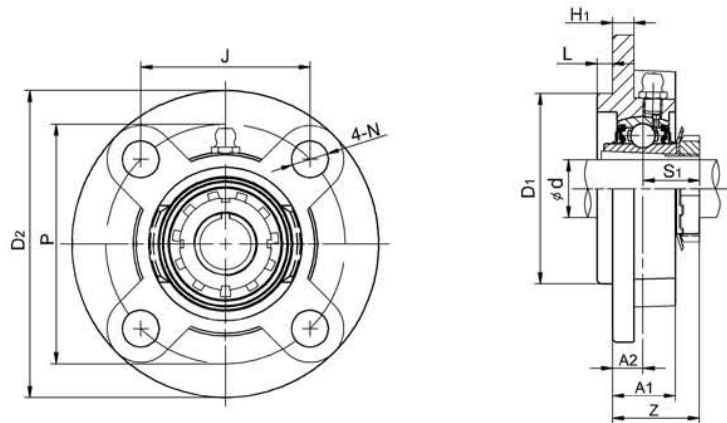

UKFC200+H Series

Unit No.	Shaft Dia		Dimensions (mm)											Bolt Size (mm)	Weight (kg)
	d		D2	P	J	A2	N	L	H1	A1	D1	S1	Z		
	(in)	(mm)													
UKFC205+H2305 205+HE2305	3/4	20	115	90	63.6	10	12	6	7	21	70	18.5	28.5	M10	0.98
UKFC206+H2306 206+HS2306 206+HA2306 206+HE2306	7/8 15/16 1	25	125	100	70.7	10	12	8	8	23	80	20.5	30.5	M10	1.2
UKFC207+H2307 207+HS2307 207+HA2307	1-1/8 1-3/16	30	135	110	77.8	11	14	8	9	26	90	22.5	33.5	M12	1.7
UKFC208+H2308 208+HE2308 208+HS2308	1-1/4 1-3/8	35	145	120	84.8	11	14	10	9	26	100	24.5	35.5	M12	2.0
UKFC209+H2309 209+HA2309 209+HE2309	1-7/16 1-1/2	40	160	132	93.3	10	16	12	10	26	105	26	36	M14	2.7
UKFC210+H2310 210+HS2310 210+HA2310 210+HE2310	1-5/8 1-11/16 1-3/4	45	165	138	97.6	10	16	12	14	28	110	27.5	37.5	M14	3.0
UKFC211+H2311 211+HS2311 211+HA2311 211+HE2311	1-7/8 1-15/16 2	50	185	150	106.1	13	19	12	15	30	125	28.5	41.5	M16	4.2
UKFC212+H2312 212+HS2312	2-1/8	55	195	160	113.1	17	19	12	15	35	135	31	48	M16	4.9
UKFC213+H2313 213+HA2313 213+HE2313 213+HS2313	2-3/16 2-1/4 2-3/8	60	205	170	120.2	16	19	14	15	36	145	32	48	M16	5.6
UKFC215+H2315 215+HA2315 215+HE2315	2-7/16 2-1/2	65	220	184	130.1	18	19	16	17	39	160	35.5	53.5	M16	7.5
UKFC216+H2316 216+HA2316 216+HE2316	2-11/16 2-3/4	70	240	200	141.4	18	23	16	18	42	170	39	57	M20	8.9
UKFC217+H2317 217+HA2317 217+HE2317	2-15/16 3	75	250	208	147.1	18	23	18	20	45	180	40	58	M20	10.4
UKFC218+H2318		80	265	220	155.5	22	23	18	20	50	190	42	64	M20	13.3

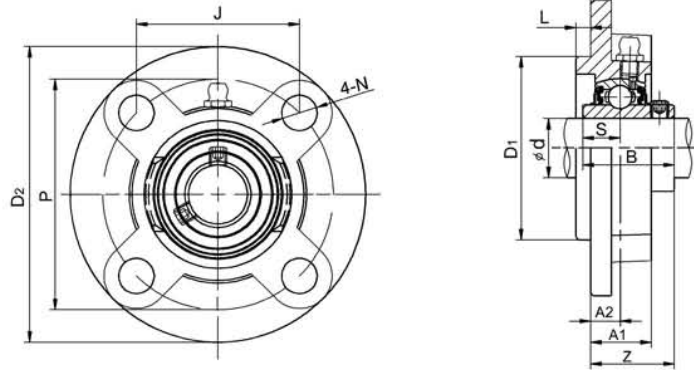

UCFCX00 Series

Unit No.	Shaft Dia		Dimensions (mm)											Bolt Size		Weight (kg)	
	d		D2	P	J	A2	N	L	H1	A1	D1	B	S	Z	(mm)		(in)
	(in)	(mm)															
UCFCX05	25		111	92	65	10	9.5	6	9.5	24	76	38.1	15.9	32.2	M8	5/16	1.2
05-13	13/16																
05-14	7/8																
05-15	15/16																
05-16	1																
UCFCX06	30		127	105	74.2	8	12	9.5	9.5	22.5	85	42.9	17.5	33.4	M10	3/8	1.5
06-17	1-1/16																
06-18	1-1/8																
06-19	1-3/16																
06-20	1-1/4																
UCFCX07	35		133	111	78.5	9	12	11	11	26	92	49.2	19	39.2	M10	3/8	1.9
07-21	1-5/16																
07-22	1-3/8																
07-23	1-7/16																
UCFCX08	40		133	111	78.5	9	12	11	11	26	92	49.2	19	39.2	M10	3/8	2.0
08-24	1-1/2																
08-25	1-9/16																
UCFCX09	45		155	130	91.9	8	14	12	11	25	108	51.6	19	40.6	M12	7/16	2.6
09-26	1-5/8																
09-27	1-11/16																
09-28	1-3/4																
09-29	1-13/16																
UCFCX10	50		162	136	96.2	7	14	16	11	25	118	55.6	22.2	40.4	M12	7/16	3.2
10-30	1-7/8																
10-31	1-15/16																
10-32	2																
UCFCX11	55		180	152	107.5	4	16	22	13	26	127	65.1	25.4	43.7	M14	1/2	4.3
11-33	2-1/16																
11-34	2-1/8																
11-35	2-3/16																
11-36	2-1/4																
11-37	2-5/16																
UCFCX12	60		194	165	116.7	11	16	20	14	33	140	65.1	25.4	50.7	M14	1/2	5.3
12-38	2-3/8																
12-39	2-7/16																
UCFCX13	65		194	165	116.7	11	16	20	14	33	140	74.6	30.2	55.4	M14	1/2	5.7
13-40	2-1/2																
13-41	2-9/16																
UCFCX14	70		222	190	134.3	14	19	20	14	36	164	77.8	33.3	58.5	M16	5/8	7.3
14-42	2-5/8																
14-43	2-1/16																
14-44	2-3/4																
UCFCX15	75		222	190	134.3	12	19	22	16	35	164	82.6	33.3	61.3	M16	5/8	8
15-45	2-13/16																
15-46	2-7/8																
15-47	2-15/16																
15-48	3																
UCFCX16	80		260	219	154.8	10	23	25	19	36	186	85.7	34.1	61.6	M20	5/8	11.3
16-49	3-1/16																
16-50	3-1/8																
16-51	3-3/16																
16-52	3-1/4																
UCFCX17	85		260	219	154.8	10	23	25	19	36	186	96	39.7	66.3	M20	3/4	12.9
17-53	3-5/16																
17-55	3-7/16																

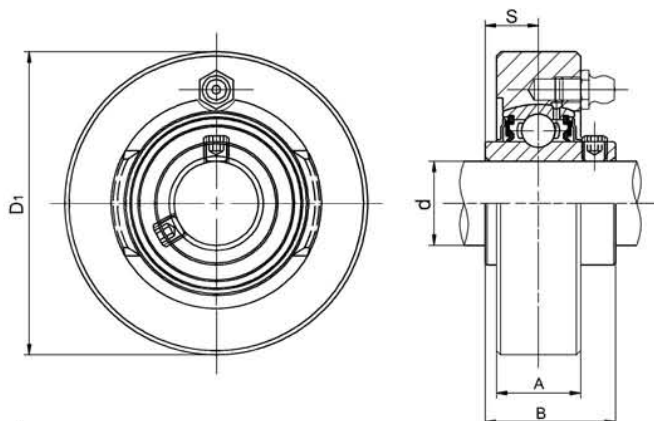

UCC200 Series

Unit No.	Shaft Dia		Dimensions(mm)				Weight (kg)
	d		D ₁	A	B	S	
	(in)	(mm)					
UCC201 201-8	1/2	12	67	20	27.4	11.5	0.56
UCC202 202-9 202-10	9/16 5/8	15	67	20	27.4	11.5	0.52
UCC203 203-11	11/16	17	67	20	27.4	11.5	0.51
UCC204 204-12	3/4	20	72	20	31.0	12.7	0.49
UCC205 205-14 205-15 205-16	7/8 15/16 1	25	80	22	34.1	14.3	0.65
UCC206 206-17 206-18 206-19 206-20	1-11/16 1-1/8 1-3/16 1-1/4	30	85	27	38.1	15.9	0.82
UCC207 207-20 207-21 207-22 207-23	1-1/4 1-5/16 1-3/8 1-7/16	35	90	28	42.9	17.5	0.93
UCC208 208-24 208-25	1-1/2 1-9/16	40	100	30	49.2	19.0	1.25
UCC209 209-26 209-27 209-28	1-5/8 1-11/16 1-3/4	45	110	31	49.2	19.0	1.53
UCC210 210-30 210-31 210-32	1-7/8 1-15/16 2	50	120	33	51.6	19.0	1.93
UCC211 211-32 211-34 211-35	2 2-1/8 2-3/16	55	125	35	55.6	22.2	2.14
UCC212 212-36 212-38 212-39	2-1/4 2-3/8 2-7/16	60	130	38	65.1	25.4	2.52
UCC213 213-40	2-1/2	65	140	40	65.1	25.4	2.97

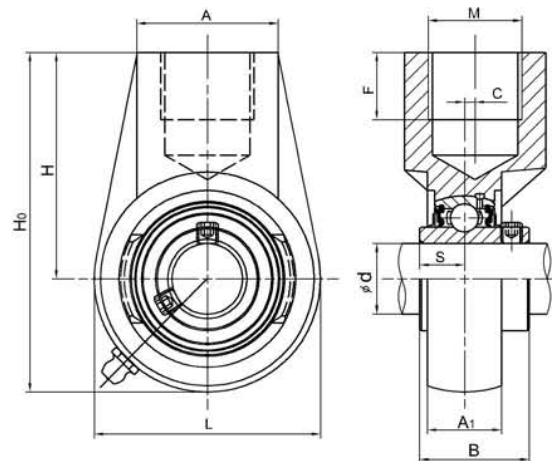

UCHA200 Series

Unit No.	Shaft Dia		Dimensions(mm)										Weight (kg)
	d		L	H ₀	H	A	M(in)	F	C	A ₁	B	S	
	(in)	(mm)											
UCHA204 204-12	3/4	20	64	96	64	40	G3/4	19	0	21	31	12.7	0.70
UCHA205 205-14 205-15 205-16	7/8 15/16 1	25	78	103	64	40	G3/4	19	0	24	34.1	14.3	0.74
UCHA206 206-17 206-18 206-19 206-20	1-1/16 1-1/8 1-3/16 1-1/4	30	78	103	64	40	G3/4	19	0	28	38.1	15.9	0.91
UCHA207 207-20 207-21 207-22 207-23	1-1/4 1-5/16 1-3/8 1-7/16	35	92	116	70	40	G3/4	19	0	30	42.9	17.5	1.19
UCHA208 208-24 208-25	1-1/2 1-9/16	40	100	123	73	40	G3/4	19	2	33	49.2	19.0	1.36
UCHA209 209-26 209-27 209-28	1-5/8 1-11/16 1-3/4	45	108	136	82	48	G1	21	5	35	49.2	19.0	1.78
UCHA210 210-30 210-31 210-32	1-7/8 1-15/16 2	50	119	142	83	48	G1	21	5	37	51.6	19.0	1.93
UCHA211 211-32 211-34 211-35	2 2-1/8 2-3/16	55	126	150	87	60	G5/4	25	7	38	55.6	22.2	3.50
UCHA212 212-36 212-38 212-39	2-1/4 2-3/8 2-7/16	60	142	173	102	60	G5/4	28	9	42	65.1	25.4	3.90
UCHA213 213-40	2-1/2	65	166	200	117	70	G1-1/2	32	9.5	44	65.1	25.4	

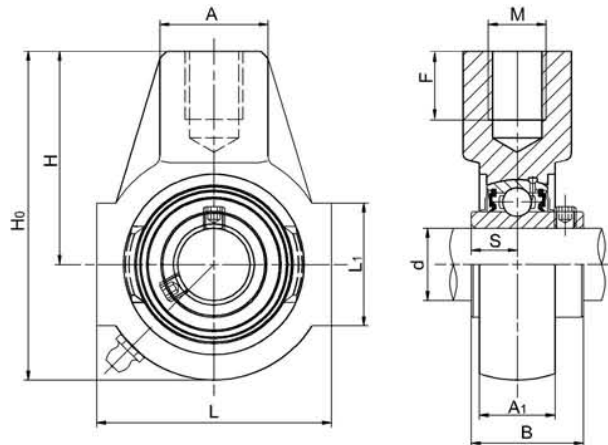

UCHE200 Series

Unit No.	Shaft Dia		Dimensions(mm)										Weight (kg)
	d		L	H ₀	H	A	M	F	L ₁	A ₁	B	S	
	(in)	(mm)											
UCHE201 201-8	1/2	12	65	91	58	30	M16	21	38	24	31	12.7	0.61
UCHE202 202-9 202-10	9/16 5/8	15	65	91	58	30	M16	21	38	24	31	12.7	0.61
UCHE203 203-11	11/16	17	65	91	58	30	M16	21	38	24	31	12.7	0.61
UCHE204 204-12	3/4	20	65	91	58	30	M16	21	38	24	31	12.7	0.61
UCHE205 205-14 205-15 205-16	7/8 15/16 1	25	70	99	64	35	M20	22	38	24	34.1	14.3	0.79
UCHE206 206-17 206-18 206-19 206-20	1-11/16 1-1/8 1-3/16 1-1/4	30	85	114	72	40	M24	24	40	32	38.1	15.9	1.23
UCHE207 207-20 207-21 207-22 207-23	1-1/4 1-5/16 1-3/8 1-7/16	35	90	122	76	40	M24	24	48	30	42.9	17.5	1.44
UCHE208 208-24 208-25	1-1/2 1-9/16	40	101	135	85	40	M24	24	45	33	49.2	19	1.82
UCHE209 209-26 209-27 209-28	1-5/8 1-11/16 1-3/4	45	110	145	90	40	M24	24	46	40	49.2	19	2.05
UCHE210 210-30 210-31 210-32	1-7/8 1-15/16 2	50	110	145	90	40	M24	24	46	40	51.6	19	2.13

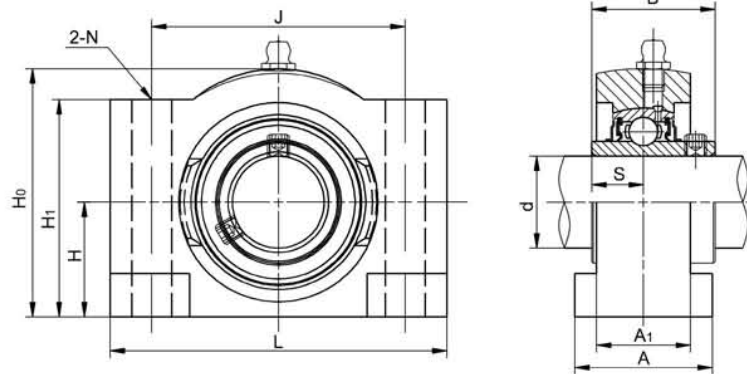

UCSB200 Series

Unit No.	Shaft Dia		Dimensions (mm)									Bolt Size		Weight (kg)	
	d		H	L	J	A	A ₁	H ₁	H ₀	N	B	S	(mm)		(in)
	(in)	(mm)													
UCSB205	25		31.7	92	70	38	25	58	67	11	34.1	14.3	M10	3/8	1.03
205-13	13/16														
205-14	7/8														
205-15	15/16														
205-16	1														
UCSB206	30		38.1	108	83	44	30	68	78	11	38.1	15.9	M10	3/8	1.63
206-17	1-1/16														
206-18	1-1/8														
206-19	1-3/16														
206-20	1-1/4														
UCSB207	35		44.4	133	102	48	33	76	94.5	14	42.9	17.5	M12	7/16	2.52
207-20	1-1/4														
207-21	1-5/16														
207-22	1-3/8														
207-23	1-7/16														
UCSB208	40		47.6	140	108	54	39	81	99.6	14	49.2	19	M12	7/16	3.12
208-24	1-1/2														
208-25	1-9/16														
UCSB209	45		50.8	146	111	54	39	86	104.8	14	49.2	19	M12	7/16	3.43
209-26	1-5/8														
209-27	1-11/16														
209-28	1-3/4														
UCSB210	50		54	152	118	60	41	90	110	14	51.6	19	M12	7/16	3.95
210-29	1-13/16														
210-30	1-7/8														
210-31	1-15/16														
210-32	2														
UCSB211	55		58.7	172	137	60	41	98	121.7	18	55.6	22.2	M16	5/8	4.92
211-32	2														
211-33	2-1/16														
211-34	2-1/8														
211-35	2-3/16														
UCSB212	60		69.9	197	162	65	48	111	146	17	65.1	25.4	M16	5/8	7.03
212-36	2-1/4														
212-37	2-5/16														
212-38	2-3/8														
212-39	2-7/16														
UCSB213	65		69.9	197	162	65	48	111	146	17	65.1	25.4	M16	5/8	7.62
213-40	2-1/2														
213-41	2-9/16														
UCSB214	70		76.2	206	172	73	60	117	155	17	74.6	30.2	M16	5/8	8.18
214-42	2-5/8														
214-43	2-11/16														
214-44	2-3/4														
UCSB215	75		76.2	206	172	73	55	117	155	17	77.8	33.3	M16	5/8	8.42
215-45	2-13/16														
215-46	2-7/8														
215-47	2-15/16														
215-48	3														
UCSB216	80		82.6	238	191	86	64	127	168	21	82.6	33.3	M20	3/4	10.55
216-50	3-1/8														
UCSB217	85		88.9	254	203	89	64	136	181	21	85.7	34.1	M20	3/4	13
217-52	3-1/4														
UCSB218	90		98.4	273	222	92	67	152	200	25	96	39.7	M24		16.29
218-56	3-1/2														
UCSBX20	100		108	298	241	108	70	178	221	26	108	49.2	M24		23.52
20-63	3-15/16														
20-64	4														