



Cam Followers

&

Roller Followers

NIPPON THOMPSON CO., LTD. (JAPAN)

Head Office : 19-13 Takanawa 2-chome Minato-ku
Tokyo 108-8586, Japan
Phone : +81 (0)3-3448-5850
Fax : +81 (0)3-3447-7637
E-mail : ntt@ikonet.co.jp
URL : http://www.ikont.co.jp/eg/
Plant : Gifu, Kamakura

IKO INTERNATIONAL, INC. (U.S.A.)

East Coast Operations (Sales Head Office)

91 Walsh Drive
Parsippany, NJ 07054
U.S.A.
Phone : +1 973-402-0254
Toll Free : 1-800-922-0337
Fax : +1 973-402-0441
E-mail : eco@ikonet.co.jp

Midwest Operations

101 Mark Street Unit G,
Wood Dale, IL 60191
U.S.A.
Phone : +1 630-766-6464
Toll Free : 1-800-323-6694
Fax : +1 630-766-6869
E-mail : mwo@ikonet.co.jp

Minnesota Sales Office

1500 McAndrews Road West, Suite 210
Burnsville, MN 55337
U.S.A.
Phone : +1 952-892-8415
Toll Free : 1-800-323-6694
Fax : +1 952-892-1722
E-mail : mwo@ikonet.co.jp

West Coast Operations

9830 Norwalk Boulevard, Suite 198
Santa Fe Springs, CA 90670
U.S.A.
Phone : +1 562-941-1019
Toll Free : 1-800-252-3665
Fax : +1 562-941-4027
E-mail : wco@ikonet.co.jp

Silicon Valley Sales Office

1500 Wyatt Drive, Suite 10
Santa Clara, CA 95054
U.S.A.
Phone : +1 408-492-0240
Toll Free : 1-800-252-3665
Fax : +1 408-492-0245
E-mail : wco@ikonet.co.jp

Southeast Operations

2150 Boggs Road, Suite 100
Duluth, GA 30096
U.S.A.
Phone : +1 770-418-1904
Toll Free : 1-800-874-6445
Fax : +1 770-418-9403
E-mail : seo@ikonet.co.jp

Southwest Operations

8105 N. Beltline Road, Suite 130
Irving, TX 75063
U.S.A.
Phone : +1 972-929-1515
Toll Free : 1-800-295-7886
Fax : +1 972-915-0060
E-mail : swo@ikonet.co.jp

IKO THOMPSON BEARINGS CANADA, INC.(CANADA)

731-2425 Matheson Boulevard East 7th floor
Mississauga, Ontario L4W 5K4, Canada
Phone : +1 905-361-2872
Fax : +1 905-361-6401
E-mail : itc@ikonet.co.jp

IKO THOMPSON BRAZIL SERVICE CO.,LTD. (BRAZIL)

Av.Paulista, 854 10th floor, Top Center,
01310-100, Sao Paulo, SP, Brazil
Phone : +55 (0)11-2186-0221
Fax : +55 (0)11-2186-0299
E-mail : itb@ikonet.co.jp

NIPPON THOMPSON EUROPE B.V. (EUROPE)

The Netherlands (Sales Head Office)

Sheffieldstraat 35-39
3047 AN Rotterdam
The Netherlands
Phone : +31 (0)10-462 68 68
Fax : +31 (0)10-462 60 99
E-mail : nte@ikonet.co.jp

Germany Branch

Mündelheimer Weg 54
40472 Düsseldorf
Germany
Phone : +49 (0)211-41 40 61
Fax : +49 (0)211-42 76 93
E-mail : ntd@ikonet.co.jp

Regensburg Sales Office

Im Gewerbepark D 30
93059 Regensburg
Germany
Phone : +49 (0)941-20 60 70
Fax : +49 (0)941-20 60 719
E-mail : ntdr@iko-nt.de

Neunkirchen Sales Office

Gruben Str. 95c
66540 Neunkirchen
Germany
Phone : +49 (0)6821-99 98 60
Fax : +49 (0)6821-99 98 626
E-mail : ntdn@iko-nt.de

U.K. Branch

2 Vincent Avenue, Crownhill
Milton Keynes, Bucks, MK8 0AB
United Kingdom
Phone : +44 (0)1908-566144
Fax : +44 (0)1908-565458
E-mail : sales@iko.co.uk

Spain Branch

Autovia Madrid-Barcelona, Km. 43,700
Polig. Ind. AIDA - Nove A-8, Ofic. 2-1ª
19200 Azuqueca de Henares
(Guadalajara) Spain
Phone : +34 949-26 33 90
Fax : +34 949-26 31 13
E-mail : nts@ikonet.co.jp

France Branch

Roissypole Le Dôme
2 rue de La Haye
BP 15950 Tremblay en France
95733 Roissy C. D. G. Cedex
France
Phone : +33 (0)1-48 16 57 39
Fax : +33 (0)1-48 16 57 46
E-mail : contact@iko-france.com

IKO THOMPSON ASIA CO., LTD. (THAILAND)

1-7 Zuellig House, 3rd Floor
Silom Road, Silom, Bangrak
Bangkok 10500, Thailand
Phone : +66 (0)2-637-5115
FAX : +66 (0)2-637-5116
E-mail : ita@ikonet.co.jp

See you again at **IKO Website**
<http://www.ikont.co.jp/eg/>

IKO THOMPSON KOREA CO.,LTD. (KOREA)

2F, 111, Yeouigongwon-ro,
Yeongdeungpo-gu, Seoul, Korea
Phone : +82 (0)2-6337-5851
Fax : +82 (0)2-6337-5852
E-mail : itk@ikonet.co.jp

IKO-THOMPSON (SHANGHAI) LTD. (CHINA)

Shanghai (Sales Head Office)
1608-10 MetroPlaza No.555 LouShanGuan Road
ChangNing District Shanghai
People's Republic of China 200051
Phone : +86 (0)21-3250-5525
Fax : +86 (0)21-3250-5526
E-mail : ntc@ikonet.co.jp

Beijing Branch

Room1506, Jingtai Tower,
NO.24, Jianguomenwai Avenue,
Chaoyang District, Beijing People's Republic of
China 100022
Phone : +86 (0)10-6515-7681
Fax : +86 (0)10-6515-7681*106
E-mail : ntc@ikonet.co.jp

Guangzhou Branch

Room 834, Garden Tower, Garden Hotel
368 Huanshi East Road, Yuexiu District, Guangzhou,
Guangdong
People's Republic of China 510064
Phone : +86 (0)20-8384-0797
Fax : +86 (0)20-8381-2863
E-mail : ntc@ikonet.co.jp

Wuhan Branch

Room 2300, Truroll Plaza No.72 Wusheng Road,
Qiao kou District, Wuhan, Hubei
People's Republic of China 430033
Phone : +86 (0)27-8556-1610
Fax : +86 (0)27-8556-1630
E-mail : ntc@ikonet.co.jp

Shenzhen Office

Room 420, Oriental Plaza,
1072 Jianshe Road, Luohu District,
Shenzhen, Guangdong
People's Republic of China 518001
Phone : +86 (0)755-2265-0553
Fax : +86 (0)755-2298-0665
E-mail : ntc@ikonet.co.jp

Ningbo Office

Room 3406, Zhongnongxin Building, No.181
Zhongshan East Road, Haishu Ward, Ningbo,
Zhejiang
People's Republic of China 315000
Phone : +86 (0)574-8718-9535
Fax : +86 (0)574-8718-9533
E-mail : ntc@ikonet.co.jp

Qingdao Office

2107 Block A, World Trade Center Building,
No.230
Changjiang Middle Road, Development Zone
Qingdao
People's Republic of China 266555
Phone : +86 (0)532-8670-2246
FAX : +86 (0)532-8670-2242
E-mail : ntc@ikonet.co.jp

Shenyang Office

2-1203 Tower I.City Plaza Shenyang, No.206
Nanjing North Street Heping District, Shenyang
People's Republic of China 110001
Phone : +86 (0)24-2334-2662
FAX : +86 (0)24-2334-2442
E-mail : ntc@ikonet.co.jp

Recognizing that conservation of the global environment is the top-priority challenge for the world's population, Nippon Thompson will conduct its activities with consideration of the environment as a corporate social responsibility, reduce its negative impact on the environment, and help foster a rich global environment.

**ISO 9001 & 14001 Quality system
registration certificate**



- The specifications and dimensions of products in this catalog are subject to change without prior notice.
- When these products are exported, the exporter should confirm a forwarding country and a use, and, in case of falling under the customer's requirements, take necessary procedures such as export permission application.
- Although all data in this catalog has been carefully compiled to make the information as complete as possible, NIPPON THOMPSON CO., LTD. shall not be liable for any damages whatsoever, direct or indirect, based upon any information in this catalog. NIPPON THOMPSON CO., LTD. makes no warranty, either express or implied, including the implied warranty of merchantability or fitness for a particular purpose.
- Reproduction and conversion without permission are prohibited.

Experts in Needle Roller Bearings.

IKD Cam Followers & Roller Followers

Cam Followers and Roller Followers are comprised of needle rollers surrounded by a thick outer ring. These bearings are designed for rotation of the outer ring, with a low coefficient of friction and excellent rotation performance.

These bearings are designed with a small radial clearance so as to effectively expand the loading zone. This ensures stable and long life by lessening the shock load as the outer ring rolls over the mating cam surface.

A wide variety of models are available in both Cam Followers with studs and Roller Followers with inner rings. Thus, an appropriate bearing can be selected for various operating conditions. They are often used for cam mechanisms or linear motion on conveying equipment.

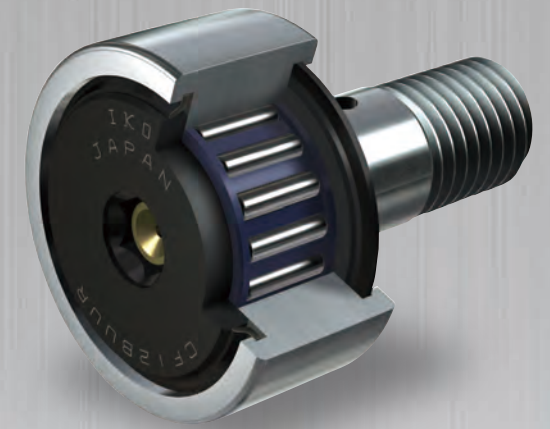

Cam Follower Series

General Explanation	5
Dimension Table	31
Introduction of Application Examples	101
Introduction of Customized Products	115
Model Comparison Table for Cam Followers	117



External Lubrication Parts for Cam Followers C-Lube Units

General Explanation	17
Dimension Table	20



Roller Follower Series

General Explanation	77
Dimension Table	85
Introduction of Application Examples	101
Model Comparison Table for Roller Followers	118

Cam Follower Series CAM FOLLOWER Series

Explanation			
Features	5	Allowable Rotational Speed	25
C-Lube Unit for Cam Followers	19	Lubrication	25
Identification Number	21	Oil Hole	26
Load Rating and Life	22	Accessories	27
Maximum Allowable Static Load	22	Special Specification	28
Accuracy	23	Operating Temperature Range	29
Radial Internal Clearance	24	Mounting	29
Fit	24	Precautions for Use	30
Track Capacity	25		

Dimension Table			
Miniature Type Cam Followers	CFS		31
Thrust Disk Type Miniature Cam Followers	CFS...W		33
Standard Type Cam Followers	CF...B		35
Double Hex Hole Cam Followers	CFKR		39
Cam Follower G	CF...G		43
Thrust Disk Type Cam Followers	CF...WB		45
C-Lube Cam Followers	CF...WB.../SG		47
Solid Eccentric Stud Type Cam Followers	CFES...B		49
Eccentric Type Cam Followers	CFE...B		51
Centralized Lubrication Type Cam Followers	CF-RU1, CF-FU1		55
Easy Mounting Type Cam Followers	CF-SFU...B		57
Cylindrical Roller Cam Followers	NUCF...B		59
Inch Series Cam Followers CR	CR...B, CR		61
Inch Series Cam Followers CRH	CRH...V, CRH...VB		69

Option Parts	
Way for Cam Follower	73

Roller Follower Series ROLLER FOLLOWER Series

Explanation			
Features	77	Track Capacity	83
Identification Number	79	Allowable Rotational Speed	83
Load Rating and Life	80	Lubrication	83
Maximum Allowable Static Load	80	Oil Hole	83
Accuracy	81	Operating Temperature Range	83
Radial Internal Clearance	82	Mounting	84
Fit	83		

Dimension Table			
Separable Roller Followers	RNAST, NAST		85
Non-separable Roller Followers	NART		89
C-Lube Roller Followers	NART.../SG		93
Cylindrical Roller Followers	NURT		95
Inch Series Non-separable Roller Followers	CRY		97

Customized Products / Model Comparison Table / Miscellaneous Tables			
Introduction of Customized Products	115	Model Comparison Table for Roller Followers	118
Model Comparison Table for Cam Followers	117	Miscellaneous Tables	119

Introduction of IKO Technical Service Site 127

Introduction of IKO Products 129



Cam Follower Series

Explanation	
Features	5
C-Lube Unit for Cam Followers	19
Identification Number	21
Load Rating and Life	22
Maximum Allowable Static Load	22
Accuracy	23
Radial Internal Clearance	24
Fit	24
Track Capacity	25
Allowable Rotational Speed	25
Lubrication	25
Oil Hole	26
Accessories	27
Special Specification	28
Operating Temperature Range	29
Mounting	29
Precautions for Use	30

Dimension Table	
Miniature Type Cam Followers	31
Thrust Disk Type Miniature Cam Followers	33
Standard Type Cam Followers	35
Double Hex Hole Cam Followers	39
Cam Follower G	43
Thrust Disk Type Cam Followers	45
C-Lube Cam Followers	47
Solid Eccentric Stud Type Cam Followers	49
Eccentric Type Cam Followers	51
Centralized Lubrication Type Cam Followers	55
Easy Mounting Type Cam Followers	57
Cylindrical Roller Cam Followers	59
Inch Series Cam Followers CR	61
Inch Series Cam Followers CRH	69

Option Parts	
Way for Cam Follower	73

IKO Cam Followers European RoHS Compliant Products

CF

IKO Cam Followers are bearings incorporating needle rollers with a stud enclosed in a thick outer ring. These Bearings are designed for outer ring rotation with superior rotational performance, a low coefficient of friction and high load capacity. Cam Followers have a high rigidity and accuracy making them well suited for various applications such as cam mechanisms and guide rollers for linear motion. They have a wide range of uses such as machine tools, industrial robots, electronic parts and office automation equipment. The hexagon socket on the stud head allows for secure tightening with a hexagon wrench as means for mounting. In addition, **IKO**'s original lubrication structure enables the Cam Follower to be lubricated from multiple locations including the stud head allowing for more freedom when designing equipment.

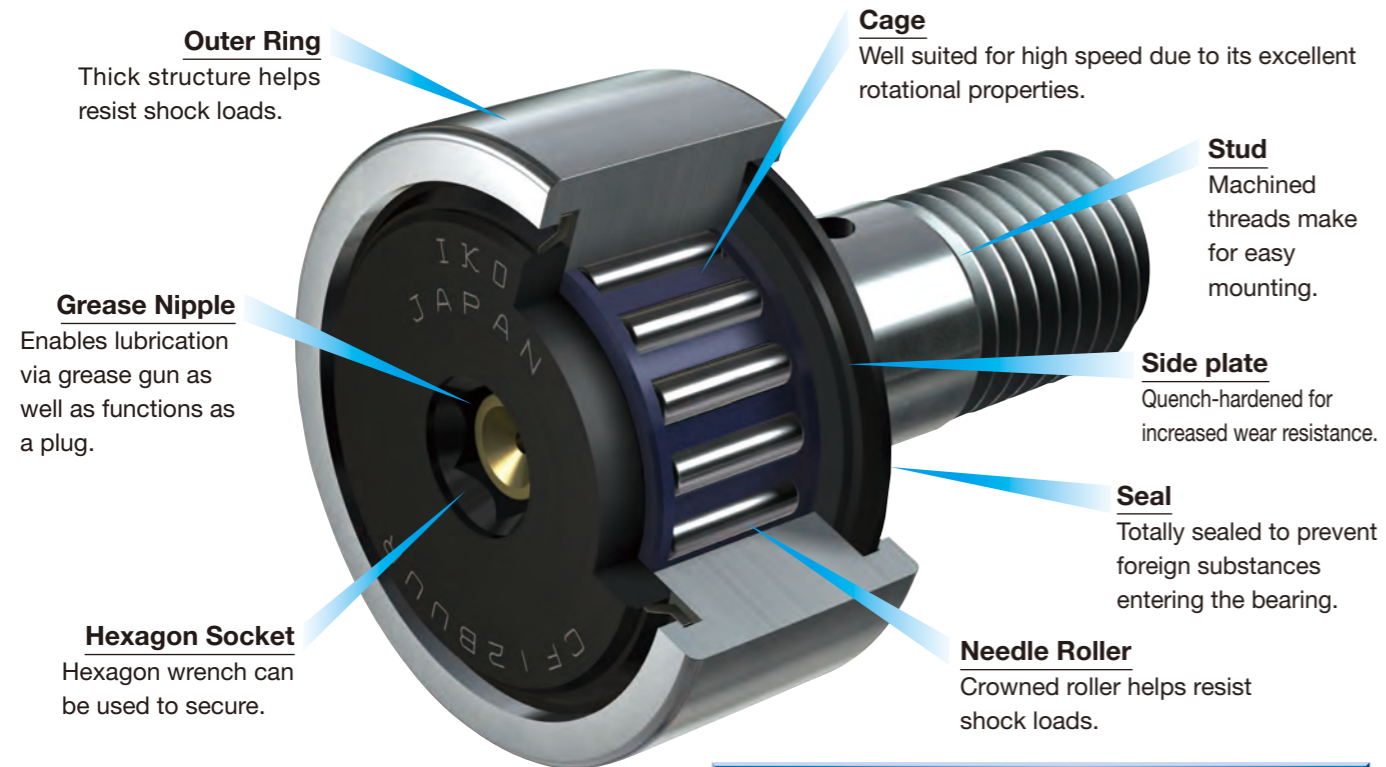

Standard Type Cam Followers



Miniature Type Cam Followers

Variety & Originality

Reliable and Proven Cam Follower Series!

Introducing the features of **IKO** Cam Follower excellence!

1 Substantial Product Lineup 7 page

Our substantial product lineup offers types such as extremely-small-sized miniature, built-in thrust disk good for mounting errors, maintenance free with pre-packed solid lubricant as well as other types.

2 Wide Selection of Product Specifications to match your needs 13 page

Options such as material type, roller guide method, seal structure and shape of the outer ring surface are available to meet the needs of your application.

3 Hexagon Socket for Easy Mounting 15 page

The hexagon socket on the stud head allows for easy means of mounting with hexagon wrench.

4 **IKO** Original Lubricating Structure which allows for lubrication from the stud head 16 page

The hexagon socket's unique design allows for grease to be administered from the stud head end.

5 New Innovation of C-Lube Unit for Cam Followers 17 page

The C-Lube unit supplies lubrication oil to the outside surface of the Cam Follower's outer ring and the track surface. Thus reducing friction and wear as well as eliminating the need to routinely grease these surfaces.

1 Substantial product lineup 1

Miniature Type Cam Followers

Stud diameter ϕ mm
2 to 6

CFS

Ultrafine needle roller is incorporated to the outer ring of bearing so the compact design is realized with outer ring outside diameter which is small relative to the stud diameter. They are used in electronic devices, OA equipment, small index devices, etc.

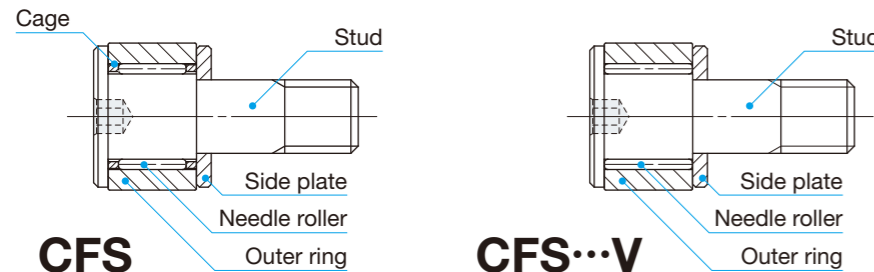

CFS

CFS...V



Selectable product specifications

Type of material	No symbol	High carbon steel
	F	Stainless steel
Roller guide method	No symbol	With cage
	V	Full complement
Seal structure	No symbol	Shield type
	UU	Sealed type
Shape of outer ring outside surface	No symbol	Cylindrical outer ring
	R	Crowned outer ring

31 page

Standard Type Cam Followers

Stud diameter ϕ mm
3 to 30

CF...B

These are the basic bearing models in the Cam Follower series. Size variations from 3 to 30 mm in stud diameter are available.

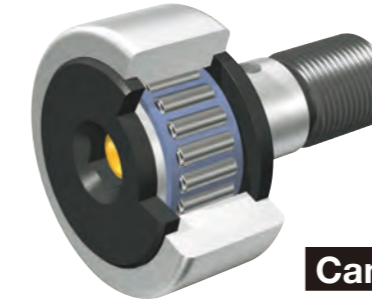

Selectable product specifications

Type of material	No symbol	High carbon steel
	F	Stainless steel
Roller guide method	No symbol	With cage
	V	Full complement
Seal structure	No symbol	Shield type
	UU	Sealed type
Shape of outer ring outside surface	No symbol	Cylindrical outer ring
	R	Crowned outer ring

Cam Follower G

CF...G

Cam Followers with pre-packed grease at reasonable price.

Can be used as-is when opened
Pre-packed grease

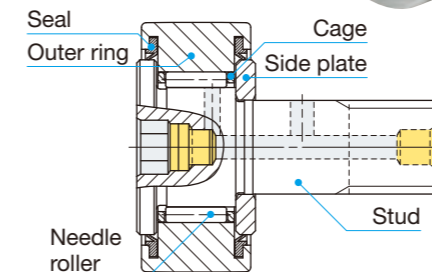

35 page

Selectable product specifications

Type of material	No symbol	High carbon steel
	F	Stainless steel
Roller guide method	No symbol	With cage
	V	Full complement
Seal structure	No symbol	Shield type
	UU	Sealed type
Shape of outer ring outside surface	No symbol	Cylindrical outer ring
	R	Crowned outer ring

Thrust Disk Type Miniature Cam Followers

Stud diameter ϕ mm
1.4 to 6

CFS...W

Miniature Type Cam Followers incorporated with special synthetic resin thrust washers excellent in wear and heat resistance. It receives axial load of outer ring generated due to installation errors to prevent friction and wear on the sliding surface.

World's smallest size!
A Cam Follower with stud diameter of just 1.4 mm!!

Ultra-compact CFS1.4WV with a stud diameter of 1.4 mm and outer ring diameter of just 4 mm. The built-in thrust disk receives the axial load of the outer ring generated due to mounting errors.

5 Features of CFS1.4WV

- 1 Stud diameter Just ϕ 1.4 mm
- 2 Outside dia. of outer ring Just ϕ 4 mm
- 3 Hexagon socket for easy mounting
- 4 Full complement type for large load capacity
- 5 Includes thrust disks to resist mounting errors

Selectable product specifications

Type of material	No symbol	High carbon steel
	F	Stainless steel
Roller guide method	No symbol	With cage
	V	Full complement
Seal structure	No symbol	Shield type
	UU	Sealed type
Shape of outer ring outside surface	No symbol	Cylindrical outer ring
	R	Crowned outer ring

33 page

Double Hex Hole Cam Followers

Stud diameter ϕ mm
10 to 30

CFKR

CFKR have a structure with hexagon sockets at each end of the stud and can be mounted using a hexagon wrench as baffle from either end, leaving the mounting location unrestricted.

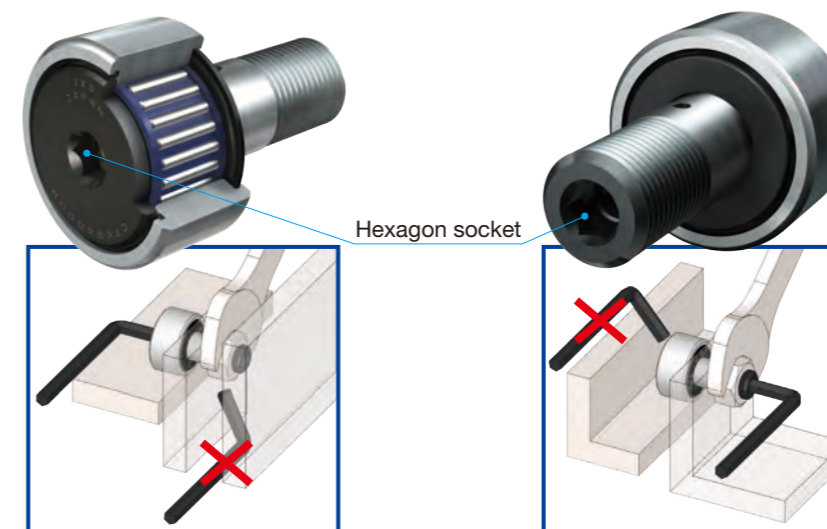

When the stud thread is interfering

When the stud head is interfering

Selectable product specifications

Type of material	No symbol	High carbon steel
	F	Stainless steel
Roller guide method	No symbol	With cage
	V	Full complement
Seal structure	No symbol	Shield type
	UU	Sealed type
Shape of outer ring outside surface	No symbol	Cylindrical outer ring
	R	Crowned outer ring

39 page

1 Substantial product lineup 2

Thrust Disk Type Cam Followers

Stud diameter ϕ mm
3 to 20

CF...WB

As it is incorporated with special synthetic resin thrust washers excellent in wear and heat resistance, it receives axial load of outer ring generated due to mounting errors to prevent friction and wear on the sliding surface.

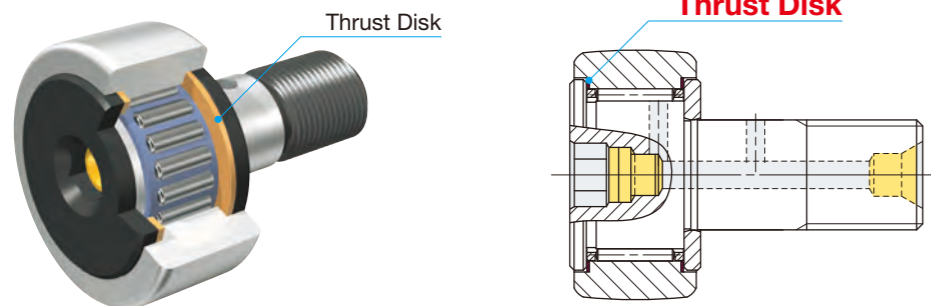

Selectable product specifications

Type of material	No symbol	High carbon steel
	F	Stainless steel
Roller guide method	No symbol	With cage
	V	Full complement
Seal structure	No symbol	Shield type
	UU	Sealed type
Shape of outer ring outside surface	No symbol	Cylindrical outer ring
	R	Crowned outer ring

45 page

C-Lube Cam Followers

Stud diameter ϕ mm
5 to 20

CF...WB.../SG

Maintenance free product with thermoset solid lubricant C-Lube pre-packed in the bearing space. C-Lube is heat-treated and solidified lubricant composed of an amount of lubrication oil and particulate ultra-high molecular polyethylene resin. As the bearing rotates, the lubricant oozes out of C-Lube onto the raceway in proper quantities, maintaining the lubrication performance for a long period of time.

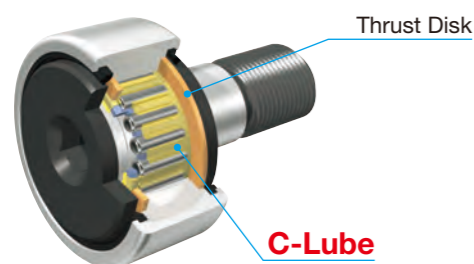

Selectable product specifications

Type of material	No symbol	High carbon steel
	F	Stainless steel
Roller guide method	No symbol	With cage
	V	Full complement
Seal structure	No symbol	Shield type
	UU	Sealed type
Shape of outer ring outside surface	No symbol	Cylindrical outer ring
	R	Crowned outer ring

<Durability Test>

Test conditions	
Test portion	CF10WBUUR/SG
Lubrication conditions	C-Lube only, no pre-packed grease
Rotational speed	1000 min ⁻¹
Ambient temperature	Room temperature

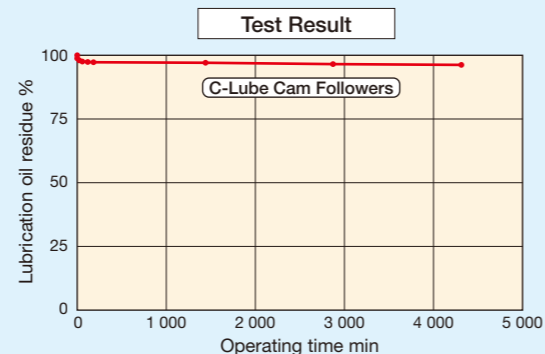

47 page

Ideal for combination with **IKO C-Lube Units for Cam Followers!!**

The combination with **IKO C-Lube Unit** for Cam Follower realizes maintenance-free of Cam Follower inside and cam guide surface.



17 page

Solid Eccentric Stud Type Cam Followers

Stud diameter ϕ mm
6 to 18

CFES...B

Rotation of eccentric stud can align height of outer ring outside diameter when multiple rings are used. Eccentricity is from 0.25 to 0.6 mm and it can be mounted to the same mounting hole as the Standard Type Cam Followers.

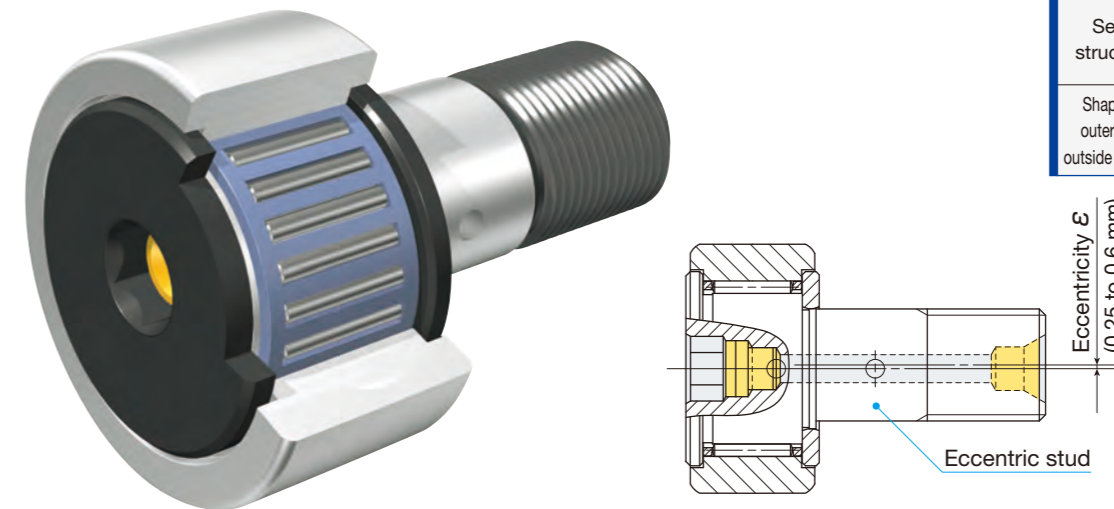

Selectable product specifications

Type of material	No symbol	High carbon steel
	F	Stainless steel
Roller guide method	No symbol	With cage
	V	Full complement
Seal structure	No symbol	Shield type
	UU	Sealed type
Shape of outer ring outside surface	No symbol	Cylindrical outer ring
	R	Crowned outer ring

49 page

Eccentric Type Cam Followers

Stud diameter ϕ mm
6 to 30

CFE...B

In these bearings, an eccentric collar is assembled with the Cam Follower stud, enabling the outer ring to be positioned easily in the radial direction against the mating cam guide surface. Eccentricity is from 0.4 to 1.5 mm.

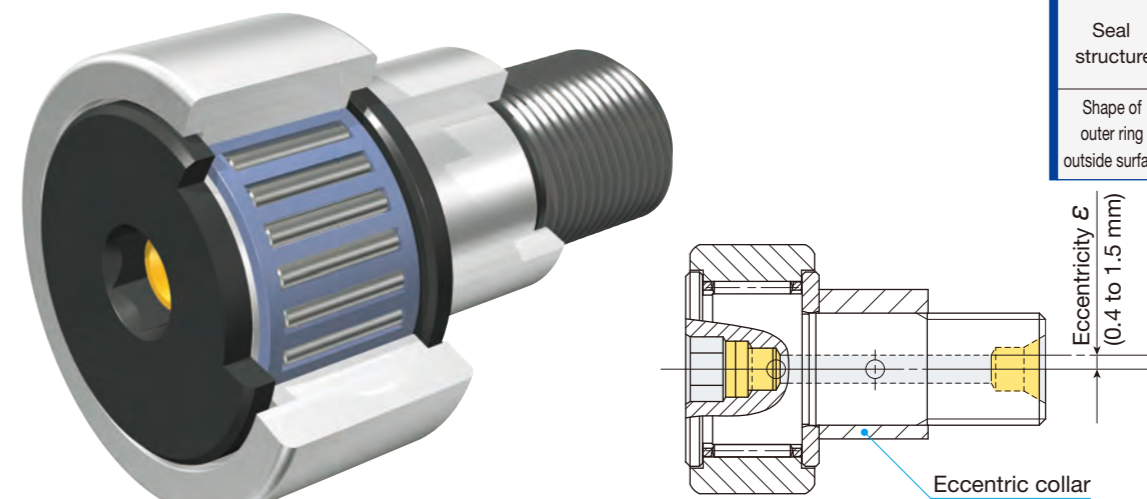

Selectable product specifications

Type of material	No symbol	High carbon steel
	F	Stainless steel
Roller guide method	No symbol	With cage
	V	Full complement
Seal structure	No symbol	Shield type
	UU	Sealed type
Shape of outer ring outside surface	No symbol	Cylindrical outer ring
	R	Crowned outer ring

51 page

1 Substantial product lineup 3

Centralized Lubrication Type Cam Followers

Stud diameter mm
6 to 30

CF-RU1, CF-FU1

As a tapped hole is prepared for the centralized piping on the stud head, this is optimal for applications where centralized oil piping is necessary.

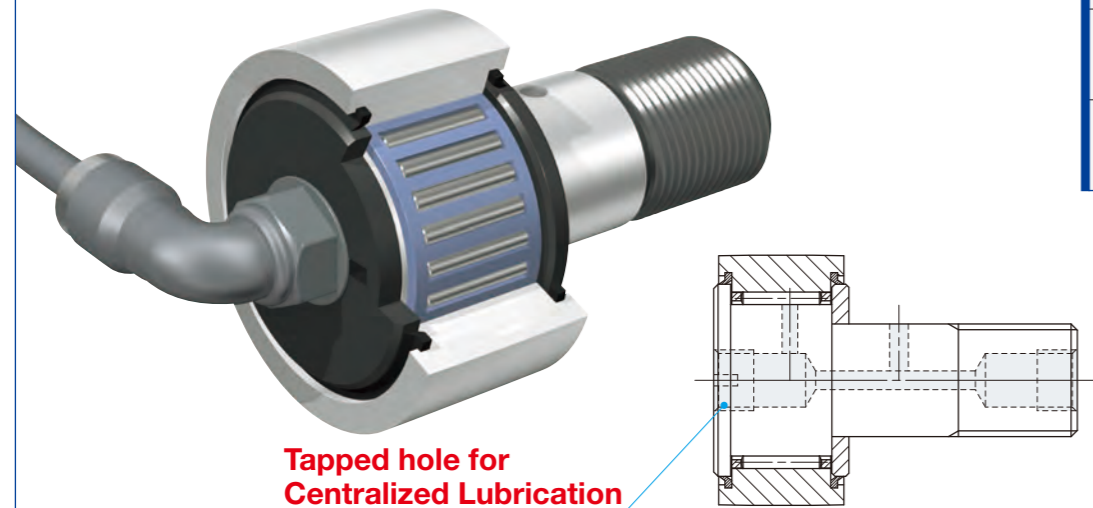

Selectable product specifications

Type of material	No symbol	High carbon steel
	F	Stainless steel
Roller guide method	No symbol	With cage
	V	Full complement
Seal structure	No symbol	Shield type
	No symbol	Sealed type
Shape of outer ring outside surface	FU1	Cylindrical outer ring
	RU1	Crowned outer ring

55 page

Cylindrical Roller Cam Followers

Stud diameter mm
10 to 30

NUCF...B

These bearings are full complement type bearings incorporating double rows of full complement cylindrical rollers in the outer ring, and can withstand large radial loads and some axial loads.

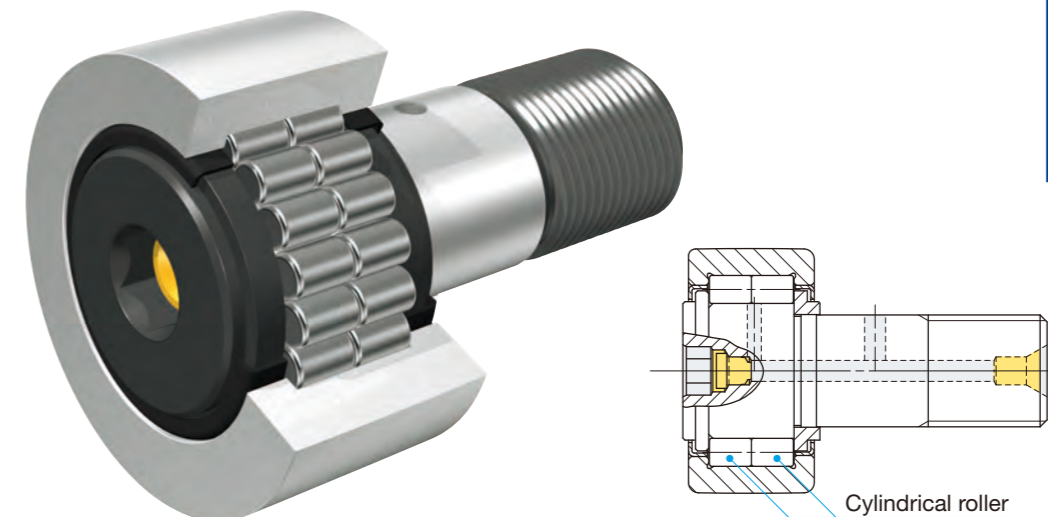

Selectable product specifications

Type of material	No symbol	High carbon steel
	F	Stainless steel
Roller guide method	No symbol	With cage
	No symbol	Full complement
Seal structure	No symbol	Shield type
	UU	Sealed type
Shape of outer ring outside surface	No symbol	Cylindrical outer ring
	R	Crowned outer ring

59 page

Easy Mounting Type Cam Followers

Stud diameter mm
6 to 20

CF-SFU...B

These bearings have a stepped tapered portion on the stud, making mounting easy by fixing a set screw to the stepped portion: thus they are optimal for applications such as pallet change.

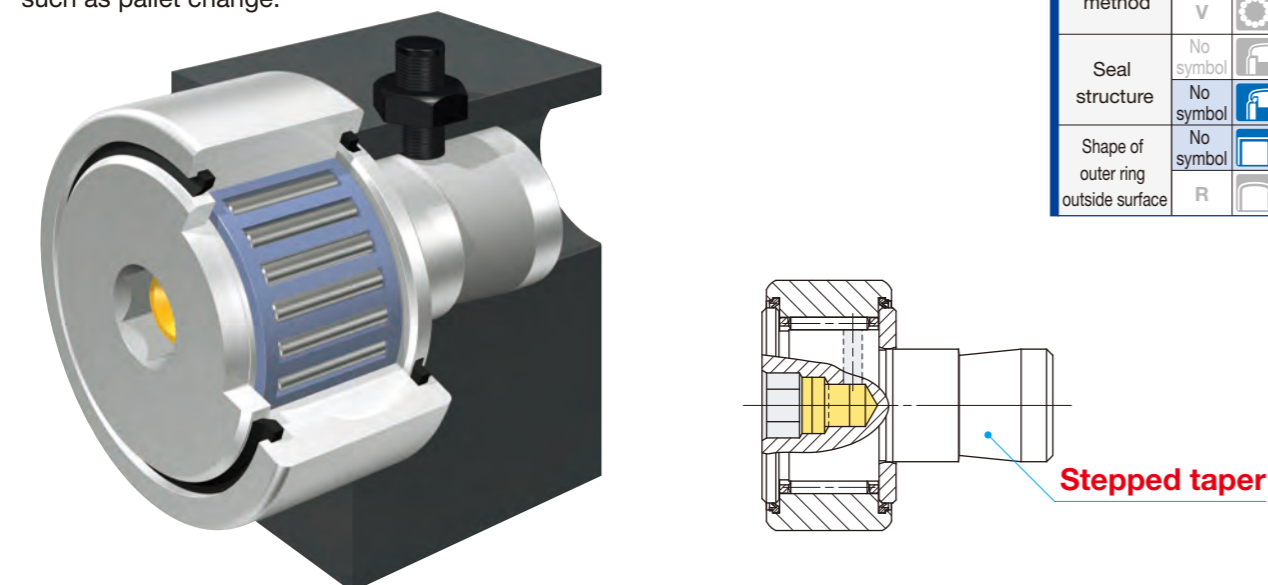

Selectable product specifications

Type of material	No symbol	High carbon steel
	F	Stainless steel
Roller guide method	No symbol	With cage
	V	Full complement
Seal structure	No symbol	Shield type
	No symbol	Sealed type
Shape of outer ring outside surface	No symbol	Cylindrical outer ring
	R	Crowned outer ring

57 page

Inch Series Cam Followers

Stud diameter mm
4.826 to 50.800

CR...B, CRH...B

2 types of Inch Series Cam Followers are available: CR and CRH. CRH has large load rating and is a heavy duty type with black oxide film treatment.

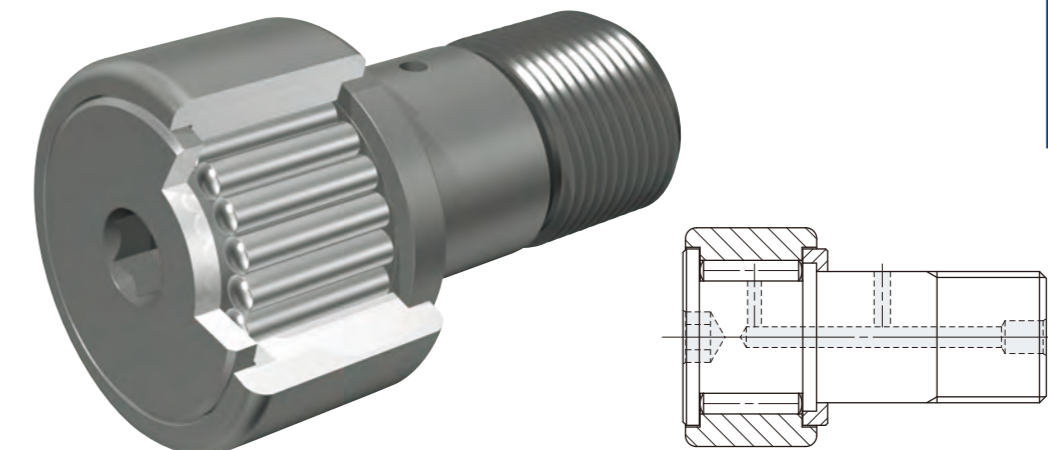

Selectable product specifications

Type of material	No symbol	High carbon steel
	F	Stainless steel
Roller guide method	No symbol	With cage
	V	Full complement
Seal structure	No symbol	Shield type
	UU	Sealed type
Shape of outer ring outside surface	No symbol	Cylindrical outer ring
	R	Crowned outer ring

61 page

2 Wide selection of product specifications for your use

IKO Cam Follower product series

Model of bearing	Type of material	Roller guide method	Seal structure	Shape of outer ring outside surface	Identification Number	Stud diameter (mm)	Dimension Table				
Miniature Type Cam Followers CFS	High carbon steel made	With cage	Shield type	Cylindrical outer ring	CFS	2 - 6	Page 31				
		Full complement	Shield type	Cylindrical outer ring	CFS...V	2 - 6	Page 31				
	Stainless steel made	With cage	Shield type	Cylindrical outer ring	CFS...F	2 - 6	Page 31				
		Full complement	Shield type	Cylindrical outer ring	CFS...FV	2 - 6	Page 31				
Thrust Disk Type Miniature Cam Followers CFS...W	High carbon steel made	With cage	Shield type	Cylindrical outer ring	CFS...W	2 - 6	Page 33				
		Full complement	Shield type	Cylindrical outer ring	CFS...WV	1.4	Page 33				
	Stainless steel made	With cage	Shield type	Cylindrical outer ring	CFS...FW	2 - 6	Page 33				
Standard Type Cam Followers CF...B	High carbon steel made	With cage	Shield type	Crowned outer ring	CF...BR	3 - 30	Page 35				
			Shield type	Cylindrical outer ring	CF...B	3 - 30	Page 35				
			Sealed type	Crowned outer ring	CF...BUUR	3 - 30	Page 35				
			Sealed type	Cylindrical outer ring	CF...BUU	3 - 30	Page 35				
		Full complement	Shield type	Crowned outer ring	CF...VBR	6 - 30	Page 37				
			Shield type	Cylindrical outer ring	CF...VB	6 - 30	Page 37				
			Sealed type	Crowned outer ring	CF...VBUUR	6 - 30	Page 37				
			Sealed type	Cylindrical outer ring	CF...VBUU	6 - 30	Page 37				
	Stainless steel made	With cage	Shield type	Crowned outer ring	CF...FBR	3 - 20	Page 35				
			Shield type	Cylindrical outer ring	CF...FB	3 - 20	Page 35				
			Sealed type	Crowned outer ring	CF...FBUUR	3 - 20	Page 35				
			Sealed type	Cylindrical outer ring	CF...FBUU	3 - 20	Page 35				
		Cam Follower G CF...G	High carbon steel made	With cage	Shield type	Cylindrical outer ring	CF...G	6 - 20	Page 43		
					High carbon steel made	With cage	Shield type	Crowned outer ring	CFKR...R	10 - 30	Page 39
							Shield type	Cylindrical outer ring	CFKR	10 - 30	Page 39
							Sealed type	Crowned outer ring	CFKR...UUR	10 - 30	Page 39
Sealed type	Cylindrical outer ring	CFKR...UU	10 - 30	Page 39							
Full complement	Shield type	Crowned outer ring	CFKR...VR	10 - 30		Page 41					
	Shield type	Cylindrical outer ring	CFKR...V	10 - 30		Page 41					
	Sealed type	Crowned outer ring	CFKR...VUUR	10 - 30		Page 41					
	Sealed type	Cylindrical outer ring	CFKR...VUU	10 - 30		Page 41					
Thrust Disk Type Cam Followers CF...WB	High carbon steel made	With cage	Shield type	Crowned outer ring	CF...WBR	3 - 20	Page 45				
			Sealed type	Crowned outer ring	CF...WBUUR	3 - 20	Page 45				
	Stainless steel made	With cage	Shield type	Crowned outer ring	CF...FWBR	3 - 5	Page 45				
			Sealed type	Crowned outer ring	CF...FWBUUR	3 - 5	Page 45				
C-Lube Cam Followers CF...WB.../SG	High carbon steel made	With cage	Sealed type	Crowned outer ring	CF...WBUUR/SG	5 - 20	Page 47				
Solid Eccentric Stud Type Cam Followers CFES...B	High carbon steel made	With cage	Shield type	Crowned outer ring	CFES...BR	6 - 18	Page 49				
			Shield type	Cylindrical outer ring	CFES...B	6 - 18	Page 49				
			Sealed type	Crowned outer ring	CFES...BUUR	6 - 18	Page 49				
			Sealed type	Cylindrical outer ring	CFES...BUU	6 - 18	Page 49				
Eccentric Type Cam Followers CFE...B	High carbon steel made	With cage	Shield type	Crowned outer ring	CFE...BR	6 - 30	Page 51				
			Shield type	Cylindrical outer ring	CFE...B	6 - 30	Page 51				
			Sealed type	Crowned outer ring	CFE...BUUR	6 - 30	Page 51				
			Sealed type	Cylindrical outer ring	CFE...BUU	6 - 30	Page 51				
		Full complement	Shield type	Crowned outer ring	CFE...VBR	6 - 30	Page 53				
			Shield type	Cylindrical outer ring	CFE...VB	6 - 30	Page 53				
			Sealed type	Crowned outer ring	CFE...VBUUR	6 - 30	Page 53				
			Sealed type	Cylindrical outer ring	CFE...VBUU	6 - 30	Page 53				
Centralized Lubrication Type Cam Followers CF-RU1 CF-FU1	High carbon steel made	With cage	Sealed type	Crowned outer ring	CF-RU1	6 - 30	Page 55				
			Sealed type	Cylindrical outer ring	CF-FU1	6 - 30	Page 55				
Easy Mounting Type Cam Followers CF-SFU...B	High carbon steel made	With cage	Sealed type	Cylindrical outer ring	CF-SFU...B	6 - 20	Page 57				
Cylindrical Roller Cam Followers NUCF...B	High carbon steel made	Full complement	Shield type	Crowned outer ring	NUCF...BR	10 - 30	Page 59				

* The product series of Inch Series Cam Followers can be found on the tables from page 61 to page 72.

Type of material

In addition to high carbon steel products, stainless steel products are also available. Stainless steel products are suited for applications where oil should be avoided, water is spattering, or it is used in a clean room.



Roller guide method

As caged type has smaller friction coefficient, it is suited for high-speed rotation. Full complement type is suited for sections where low-speed rotation, oscillatory movement or heavy load exists.

For sections with high-speed rotation...

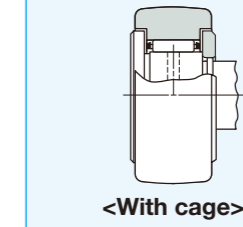

For sections with low-speed rotation or heavy load...

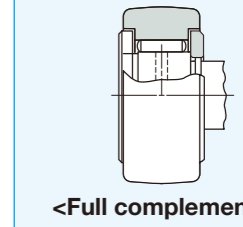

Maximum revolution comparison

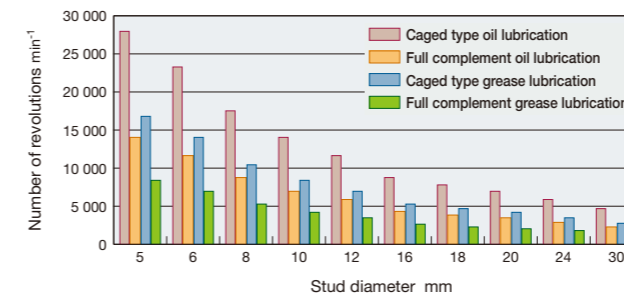

Dynamic load rating comparison

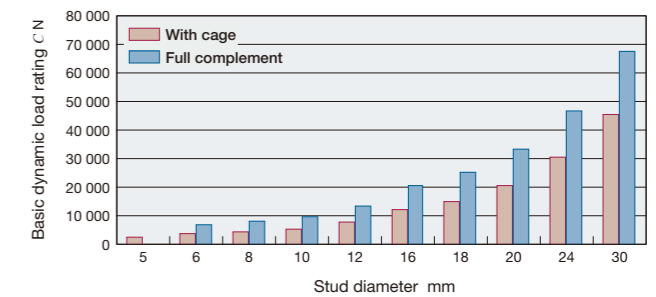

Seal structure

Shield type is shaped so that clearance between the outer ring and stud flange and between the outer ring and side plate become smaller and labyrinth is formed. Sealed type incorporates the seal structure, which can prevent foreign substances from entering.

For general use...

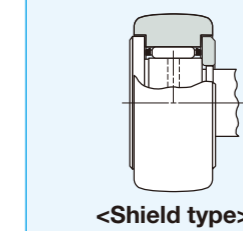

For dust prevention and grease leak prevention...

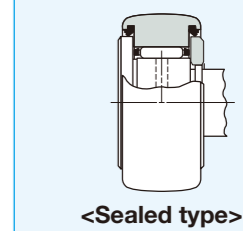

Shape of outer ring outside surface

Crowned outer ring is effective for mitigation of edge load generated due to mounting errors. Cylindrical outer ring is suited if the applied load is large or hardness of cam guide surface is low.

For reducing mounting errors...

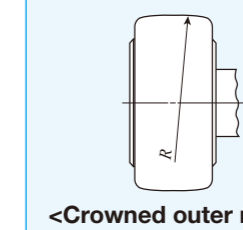

For sections with high applied load... For cam guide surfaces without enough hardness...

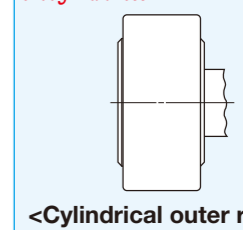

Track surface load capacity comparison

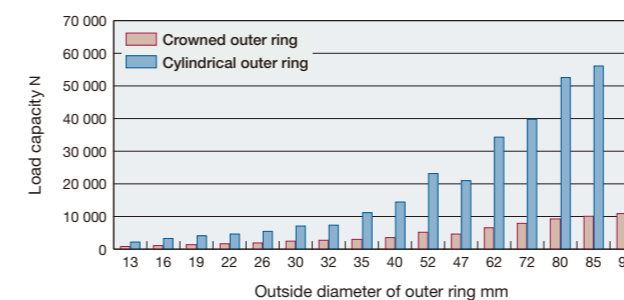

3 Hexagon Socket for easy mounting

Easily secure stud

with the help of a hexagon wrench!

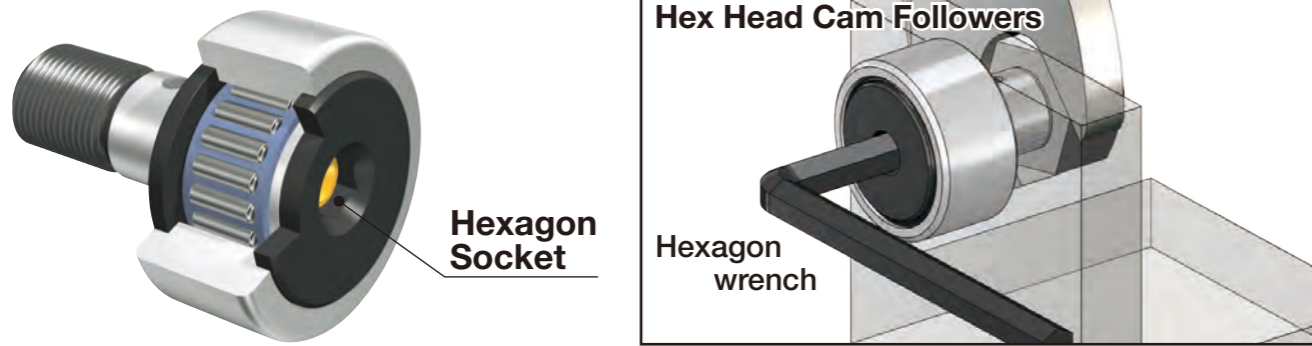

Hexagon socket is available in the following series

Series name	Model	Stud diameter (mm)
Miniature Type Cam Followers	CFS	2 to 6
Thrust Disk Type Miniature Cam Followers	CFS...W	1.4 to 6
Standard Type Cam Followers	CF...B	3 to 30
Double Hex Hole Cam Followers	CFKR	10 to 30
Thrust Disk Type Cam Followers	CF...WB	3 to 20
C-Lube Cam Followers	CF...WB.../SG	5 to 20
Solid Eccentric Stud Type Cam Followers	CFES...B	6 to 18
Eccentric Type Cam Followers	CFE...B	6 to 30
Easy Mounting Type Cam Followers	CF-SFU...B	6 to 20
Cylindrical Roller Cam Followers	NUCF...B	10 to 30
Inch Series Cam Followers	CR...B, CRH...B	4.826 to 50.800

* Centralized Lubrication Type Cam Followers come with a screwdriver slot.

CFKR is designed with hexagon sockets at each end of the stud, allowing for use in any mounting location!

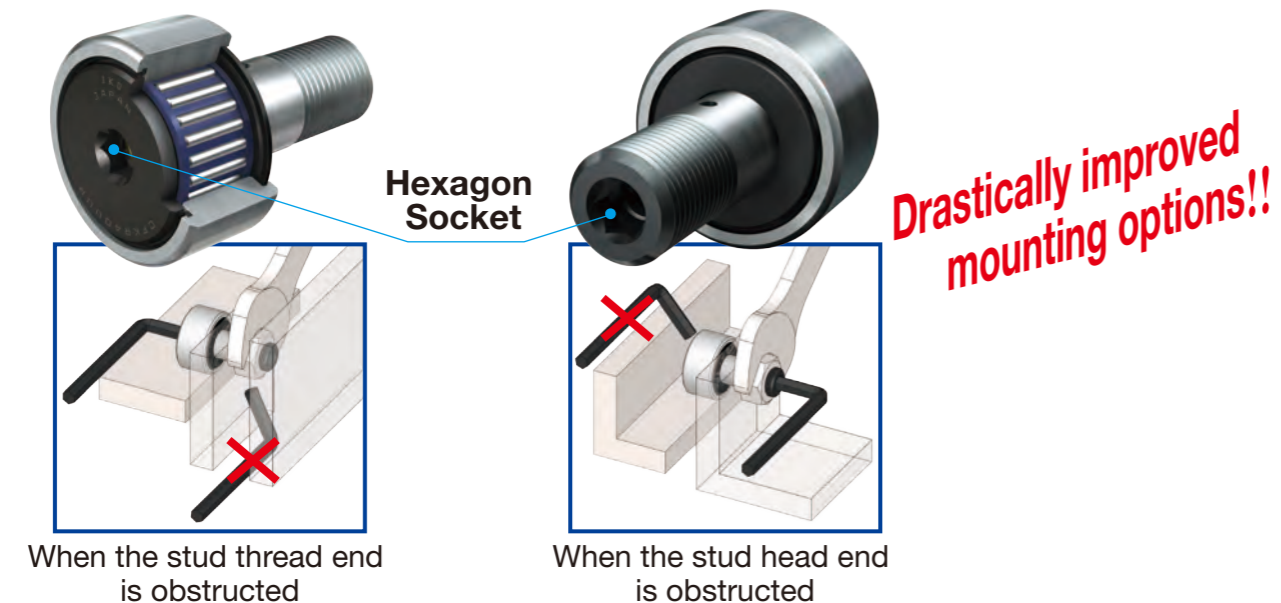

4 IKO Original Lubricating Structure which allows for lubrication from the stud head

Original lubricating structure

Hex Head Cam Followers allow lubrication from the stud head.⁽¹⁾



3 Way Type

Stud dia. 12 to 30 mm⁽²⁾

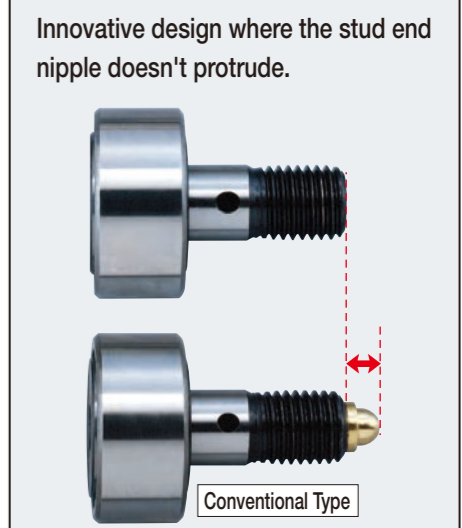
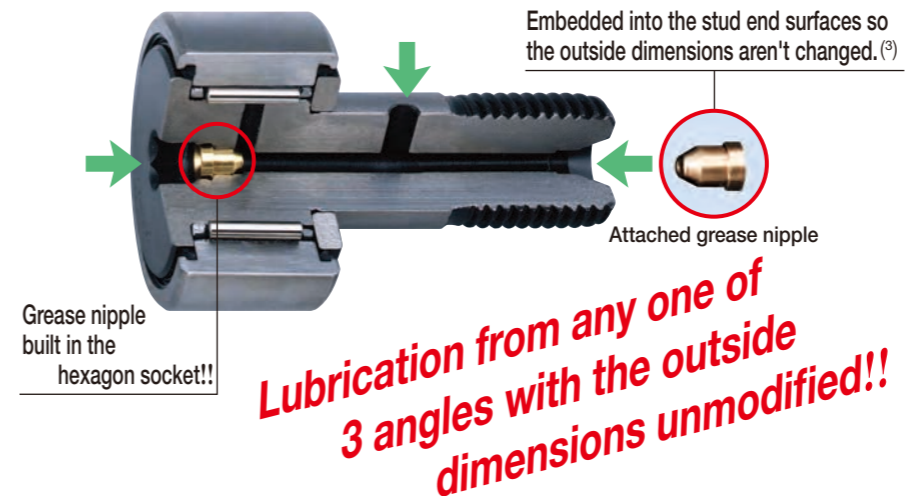

Furthermore, there is no need to differentiate between the use of a plug or a grease nipple depending on the lubrication direction.



1 Way Type

Stud dia. 5 to 10 mm⁽⁴⁾

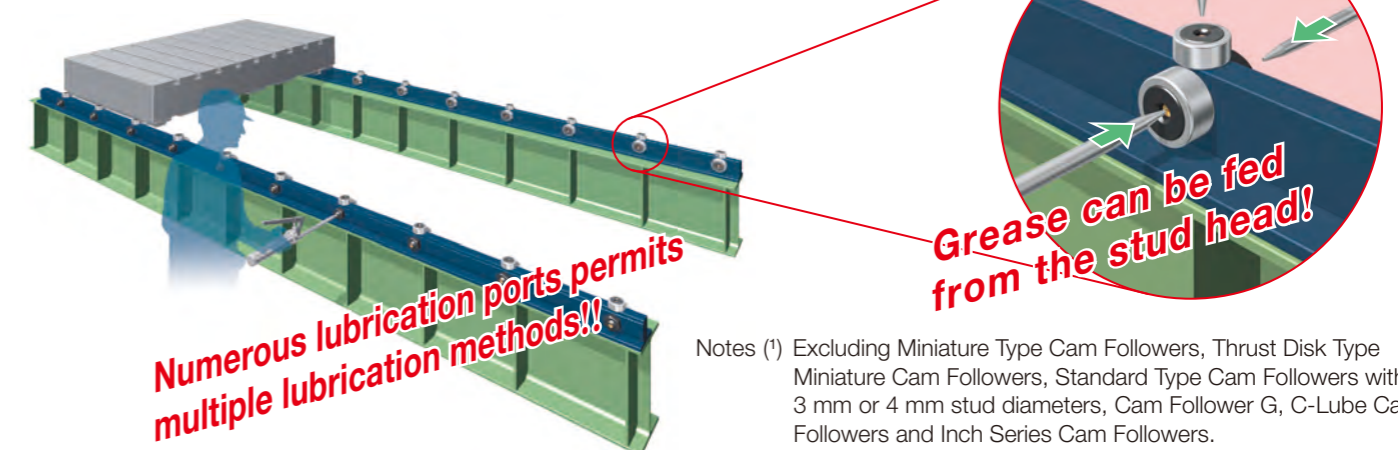
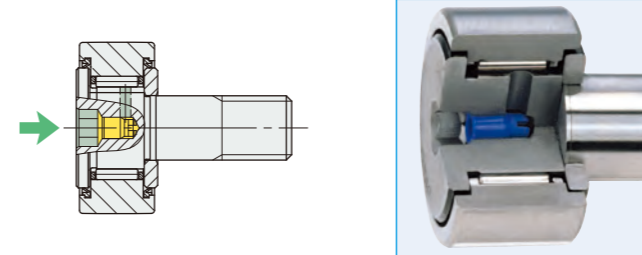

Notes (1) Excluding Miniature Type Cam Followers, Thrust Disk Type Miniature Cam Followers, Standard Type Cam Followers with 3 mm or 4 mm stud diameters, Cam Follower G, C-Lube Cam Followers and Inch Series Cam Followers.
 (2) Eccentric Type Cam Followers have a stud thread diameter G as shown in the dimension table.
 Furthermore, all Easy Mounting Type have a 1way port.
 (3) Grease nipple for stud end is included as an accessory.
 (4) Oil holes are provided at the head part and the stud end for Double Hex Hole Cam Followers only. (2 Way Type)

5 New Innovation of C-Lube Unit for Cam Followers

IKO C-Lube Unit for Cam Followers

CL

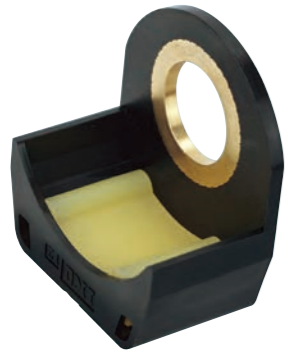

IKO C-Lube Unit for Cam Followers is a lubrication component that mounts on Cam Followers. Frequent lubrication is not required since oil is administered to the outer ring and track surfaces.

19 page

Long-term operation without the need for costly frequent lubrication!

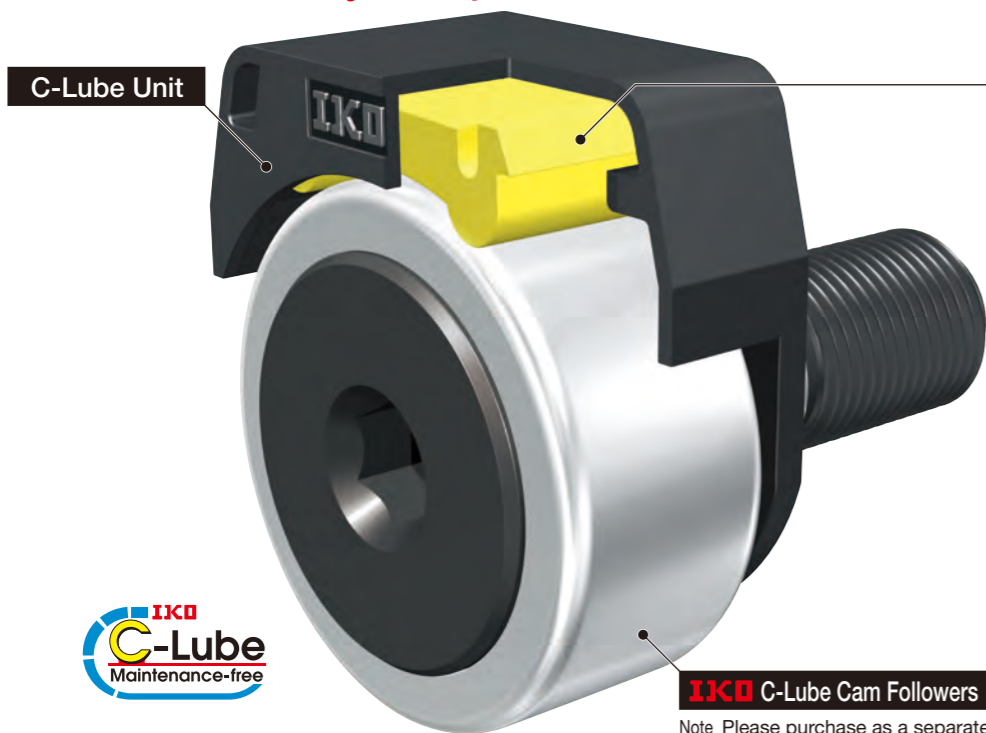

Capillary lubricating element

Constructed by sintering a fine resin powder into a porous mold. The porous mold is then saturated with a large amount of lubrication oil.



Resin particles are firmly fused together with numerous empty spaces.



Lubricant is retained in cavities amongst resin particles.

IKO C-Lube Cam Followers

Note Please purchase as a separate addition to the IKO C-Lube Unit.



Are you struggling with problems like this?

When lubrication maintenance of cam guide surfaces is not right...
Lubrication oil runs low allowing wear and reddish-brown rust to appear!
Too much grease causes it to scatter, thus contaminating the surrounding environment!



C-Lube Unit CL

If so, problem solved!!

Lubrication oil is continuously applied for a long period of time!



Prevents contamination to the surrounding environment!

IKO C-Lube Unit For Cam Follower CL Applications

Achieves long term maintenance free cam guide surfaces!!

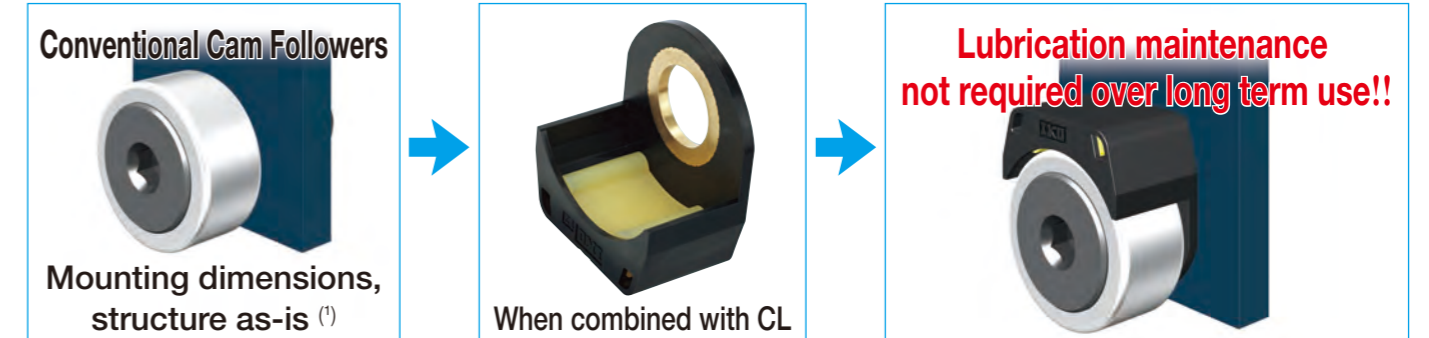

Notes (1) Cam Followers only need to be offset by a few mm in the axial directions to cater for the CL resin cover thickness.

CL properties are underpinned by extensive durability testing!

<Durability test>

Test conditions (2)	
Test portion	CL12 C-Lube Unit For Cam Followers CF12 WBUUR/SG C-Lube Cam Followers
Lubrication conditions	C-Lube Unit only, no pre-packed grease
Maximum speed	2000 mm/s
Stroke length	300 mm
Track surface specifications	Material SKD11 Hardness HRC58 or more Surface Roughness Rz: 6.3 μm or less
Ambient temperature	Room temperature

Notes (2) Uses a ground cam guide surface with verified durability. If using under different conditions, please confirm with your actual machine.

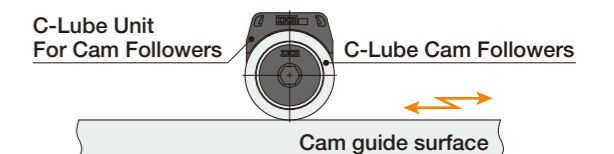
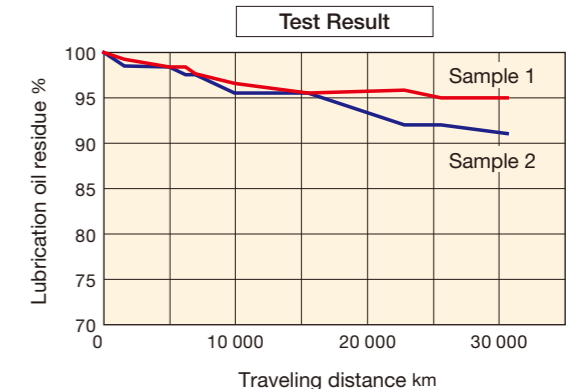

Ideal for use in combination with IKO C-Lube Cam Followers!!

The combination of IKO Cam Followers CF...WB.../SG with the IKO C-Lube Unit for Cam Followers provides for maintenance-free operation both inside and outside the Cam Follower as well as the track surface.

Completely maintenance free!

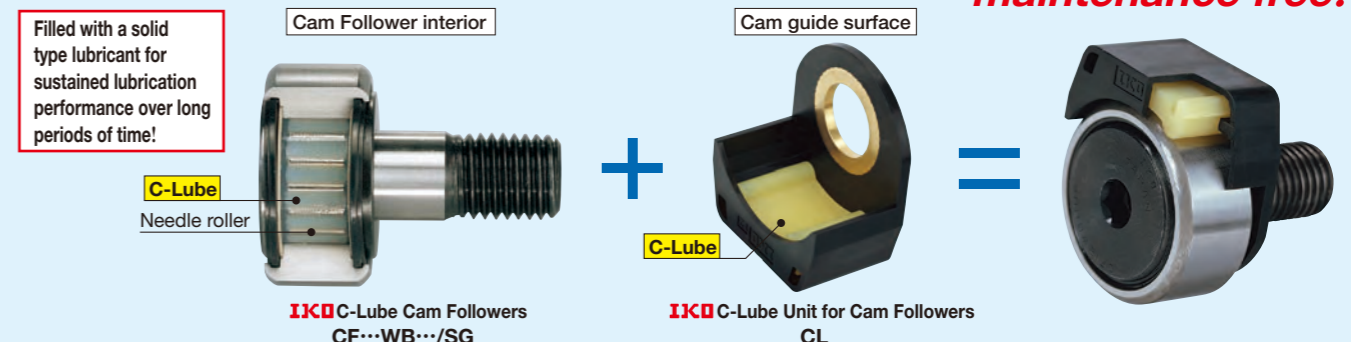

Remark C-Lube Unit can be used in combination with Standard Type Cam Followers, Double Hex Hole Cam Followers, Cam Follower G, Thrust Disk Type Cam Followers, Centralized Lubrication Type Cam Followers, C-Lube Cam Followers and Cylindrical Roller Cam Followers.

C-Lube Unit for Cam Followers

1 Identification Number

An example of the identification number of C-Lube Unit for Cam Followers is shown below.

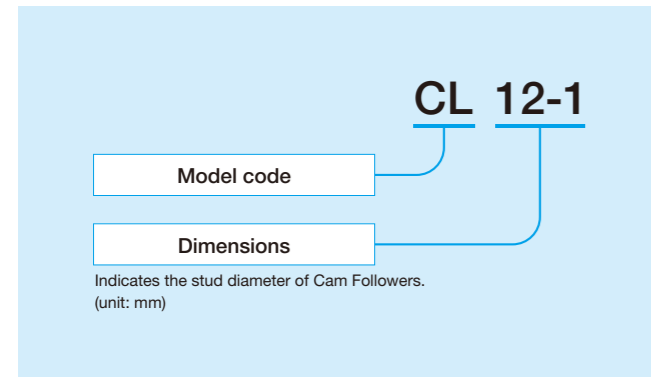

2 Allowable Rotational Speed

For Cam Followers with C-Lube Unit mounted, use 10,000 or lower as reference for the $d_1 n$ value.

$$d_1 n \text{ value} = d_1 \times n$$

where d_1 : Stud diameter of Cam Follower mm
 n : Rotational speed min^{-1}

3 Minimum Rotational Angle

Lubrication oil is supplied to the whole outside diameter surface of the outer ring. Accordingly, when the C-Lube Unit is mounted, use the product in conditions under which the outer ring makes one or more turns.

4 Operating Temperature Range

Use the C-Lube Unit within the temperature range between -15°C and 80°C .

5 Mounting

Set the C-Lube Unit perpendicularly to a center line of the Cam Follower stud and fix it along with the Cam Follower with a nut. (See Fig. 1)

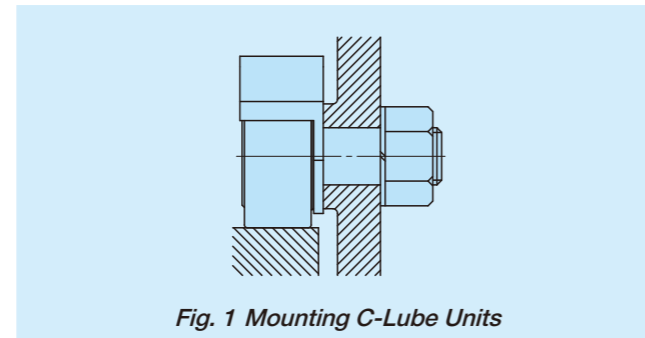

C-Lube Unit must be positioned avoiding loading direction. In addition, the C-Lube Unit has no baffle, so fix it while adjusting the C-Lube Unit position in mounting. (See Fig. 2)

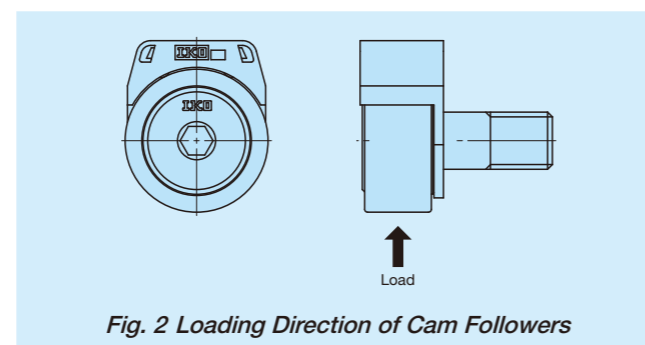

Tighten the nut to fix the C-Lube Unit and Cam Followers together to the extent not exceeding the maximum tightening torque specified in the Cam Followers dimension table.
 In case loosening of the nut is predicted due to vibration, using lock nut, spring washer and other self-locking nut are recommended.

6 Precautions for Use

- Never clean up a C-Lube Unit with organic solvent or white kerosene with property of removing fat.
- To avoid damage and lubrication function failure, do not directly apply load onto the C-Lube Unit.
- To rotate the Cam Followers normally with the C-Lube Unit mounted, apply load of 1% or more of the basic dynamic load rating to the Cam Followers.
- Load applied to the Cam Follower with the C-Lube Unit equipped must be 80% or less of the maximum allowable static load of the Cam Follower to be combined. Excessive load may deform the C-Lube Unit mounting surface, loosen the Cam Follower fixed nut, or dislodge the C-Lube Unit, preventing normal operation.

- Before operation, ensure that lubrication oil is supplied between the Cam Followers outer ring outside surface and the cam guide surface. Lubrication performance of the C-Lube Unit is largely affected by conditions of the cam guide surface.
- Avoid operating the C-Lube Unit in any environment where capillary lubricating elements may be damaged or foreign substances or liquid substance may enter into it.
- As additional oil feeding to the C-Lube Unit is not allowed, replace it with new one when lubrication effect is lost.

7 Dimension Table

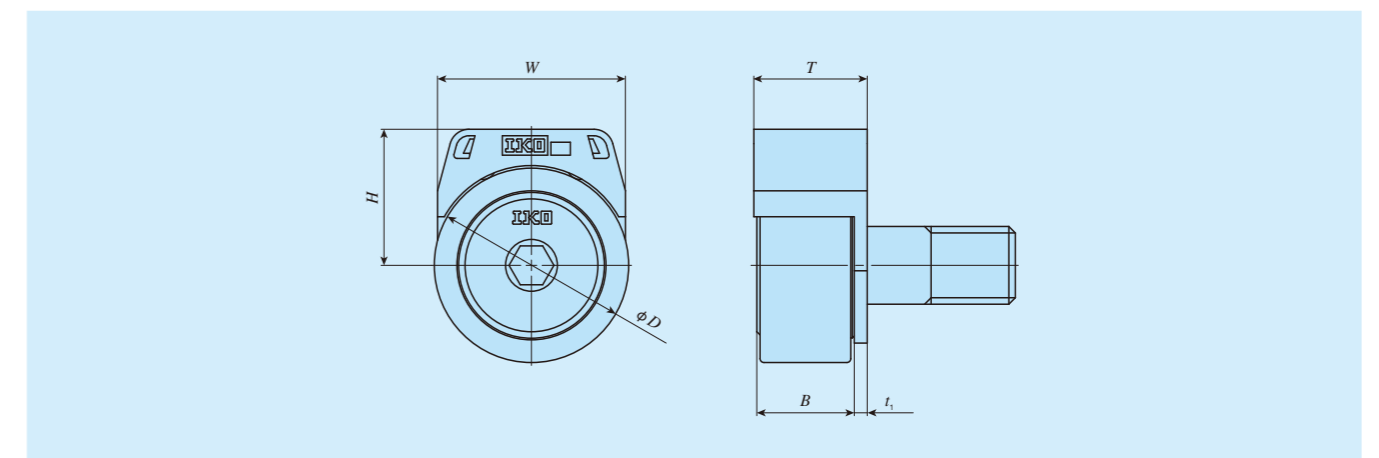

Identification number	Boundary dimensions mm				Applicable Cam Followers		
	W	H	T	t_1	Identification number	Boundary dimensions mm	
						D	B
CL 5	12.4	10.7	12.1	1.5	CF 5 B	13	10
CL 6	15.4	12.6	14	1.5	CF 6 B	16	12.2 max
CL 8	18.4	14.2	14	1.5	CF 8 B	19	12.2 max
CL 10	21	17	15.5	2	CF 10 B CFKR 22	22	13.2 max
CL 10-1	21	19.2	15.5	2	CF 10-1 B CFKR 26	26	13.2 max
CL 12	29	21	17.5	2	CF 12 B CFKR 30	30	15.2 max
CL 12-1	29	22	17.5	2	CF 12-1 B CFKR 32	32	15.2 max
CL 16	33.8	27.4	23.4	2.5	CF 16 B CFKR 35	35	19.6 max
CL 18	38.8	30.4	25.4	2.5	CF 18 B CFKR 40	40	21.6 max
CL 20	45.8	38.4	29.9	3	CF 20 B CFKR 52	52	25.6 max
CL 20-1	45.8	35.4	29.9	3	CF 20-1 B CFKR 47	47	25.6 max

Note (!) Only representative types are shown in the table, but this table is applicable to the same size of Standard Type Cam Followers, Double Hex Hole Cam Followers, Cam Follower G, Thrust Disk Type Cam Followers, Centralized Lubrication Type Cam Followers, C-Lube Cam Followers and Cylindrical Roller Cam Followers.

Use in combination with C-Lube Cam Followers is strongly recommended for full maintenance free effect.
 Remark Load applied to the Cam Follower with the C-Lube Unit equipped must be 80% or less of the maximum allowable static load of the Cam Follower to be combined. For the maximum allowable static load of each Cam Follower, please see the dimension tables of respective models.

Identification Number

Examples of the identification number of Cam Followers are shown below. In addition, for application of material type, roller guide method, seal structure and shape of outer ring outside surface to each model, refer to the dimension table.

Example	Model Code
Example 1	CFS 3 F V P6
Example 2	CF 10 V B UU R
Example 3	CF 5 F W B UU R
Example 4	CF 8 W B UU R /SG

Model code	
CFS	Miniature Type Cam Followers
CFS···W	Thrust Disk Type Miniature Cam Followers
CF···B	Standard Type Cam Followers
CFKR	Double Hex Hole Cam Followers
CF···G	Cam Follower G
CF···WB	Thrust Disk Type Cam Followers
CF···WB···/SG	C-Lube Cam Followers
CFES···B	Solid Eccentric Stud Type Cam Followers
CFE···B	Eccentric Type Cam Followers
CF-RU1	Centralized Lubrication Type Cam Follower (Crowned Outer Ring)
CF-FU1	Centralized Lubrication Type Cam Follower (Cylindrical Outer Ring)
CF-SFU···B	Easy Mounting Type Cam Followers
NUCF···B	Cylindrical Roller Cam Followers
CR···B	Inch Series Cam Followers (With Hexagon Socket)
CR	Inch Series Cam Followers (With Screwdriver Slot)
CRH···B	Inch Series Cam Followers (With Hexagon Socket)
CRH	Inch Series Cam Followers (With Screwdriver Slot)

Dimensions	
The value indicates the stud diameter. (unit: mm) (The outside diameter of the outer ring is indicated for Double Hex Hole Cam Followers only.) For Inch Series Cam Followers, outer ring outside diameter dimensions are indicated in 1/16 inch.	

Type of material	
No symbol	High carbon steel made
F	Stainless steel made

Roller guide method (!)	
No symbol	With cage
V	Full complement

Note (!) Cylindrical Roller Cam Followers are full complement type with no symbol.

Seal structure (!)	
No symbol	Shield type
UU	Sealed type

Note (!) Centralized Lubrication Type and Easy Mounting Type Cam Followers are sealed type with no symbol.

Shape of outer ring outside surface	
No symbol	Cylindrical outer ring
R	Crowned outer ring

Accuracy class	
No symbol	Accuracy class 0
P6	Accuracy class 6
P5	Accuracy class 5
P4	Accuracy class 4

Applicable to Miniature Type Cam Followers CFS and CFS···W.

Load Rating and Life

Basic dynamic load rating C

Basic dynamic load rating refers to a static radial load with a certain direction and size with which 90% of a group of the same Cam Followers can run one million rotations without material damages due to rolling contact fatigue when they are operated in the same conditions.

Basic static load rating C₀

Basic static load rating refers to a static radial load with a certain direction and size with a certain contact stress at the center of contact parts of the rolling elements and a raceway under maximum load.

Life

The basic rating life calculation formulas are shown below.

$$L_{10} = \left(\frac{C}{P_r}\right)^{10/3} \dots\dots\dots(1)$$

Where, L₁₀ : Basic rating life 10⁶ rev.
C : Basic dynamic load rating N
P_r : Dynamic equivalent radial load N

Therefore, life time can be calculated by applying the rotational speed to the formula below.

$$L_h = \frac{10^6 L_{10}}{60n} \dots\dots\dots(2)$$

Where, L_h : Basic rating life represented by service hours h
n : Rotational speed min⁻¹

Static Safety Factor

Static safety factor can be obtained by the following equation and typical values are shown in Table 1.

$$f_s = \frac{C_0}{P_{or}} \dots\dots\dots(3)$$

Where, f_s : Static safety factor
C₀ : Basic static load rating N
P_{or} : Static equivalent radial load (maximum load) N

Table 1 Static safety factor

Operating conditions of the bearing	f _s
When high rotational accuracy is required	≥3
For ordinary operation conditions	≥1.5
For normal operating conditions not requiring very smooth rotation When it is rarely rotated	≥1

Load factor

Load actually applied on the Cam Followers becomes larger than load theoretically calculated from vibration and shock. Therefore, multiply the load by the load factor shown in Table 2.

Table 2 Load factor

Operating conditions	f _w
Smooth operation free from shock	1 to 1.2
Normal operation	1.2 to 1.5
Operation with shock load	1.5 to 3

Maximum Allowable Static Load

The applicable load on Cam Followers is, in some cases, limited by the bending strength and shear strength of the stud and the strength of the outer ring instead of the load rating of the needle roller bearing. Therefore, the maximum allowable static load that is limited by these strengths is specified.

Accuracy

The accuracy of Cam Followers is shown in Table 3, Table 4.1, Table 4.2, and Table 4.3. We also provide special accuracy class products. For details, please contact **IKO**.

Table 3 Tolerances unit: μm

Item	Series	Standard Type Cam Followers (1)		Inch Series Cam Followers	
		Miniature Type Cam Followers CFS, CFS...W	Crowned outer ring	Cylindrical outer ring	Crowned outer ring
Outside dia. of outer ring D	See Table 4.1	0 -50	See Table 4.2	0 -50	See Table 4.3
Stud diameter d_1	h6	h7		+ 25 0	
Width of outer ring C	0 -120	0 -120	0 -130		

Note (1) Applicable for Cam Followers other than Miniature Type Cam Followers and Inch Series Cam Followers.

Table 4.1 Tolerance and allowance of outer ring (Miniature Type Cam Followers CFS and CFS...W) unit: μm

ΔD_{mp} Deviation of mean outside diameter in a single plane								K_{ca} Radial runout of outer ring of assembled bearing (Maximum)			
Class 0		Class 6		Class 5		Class 4		Class 0	Class 6	Class 5	Class 4
High	Low	High	Low	High	Low	High	Low				
0	-8	0	-7	0	-5	0	-4	15	8	5	4

Table 4.2 Tolerance and allowance of outer ring (Standard Type Cam Followers, Cylindrical outer ring) unit: μm

D Nominal outside diameter of outer ring mm		ΔD_{mp} Deviation of mean outside diameter in a single plane		V_{Dsp} Variation of outside diameter in a single plane (Maximum)	V_{Dmp} Variation of mean outside diameter (Maximum)	K_{ca} Radial runout of outer ring of assembled bearing (Maximum)
Over	Incl.	High	Low			
6	18	0	- 8	10	6	15
18	30	0	- 9	12	7	15
30	50	0	-11	14	8	20
50	80	0	-13	16	10	25
80	120	0	-15	19	11	35

Table 4.3 Tolerance and allowance of outer ring (Inch series Cam Followers, Cylindrical outer ring) unit: μm

D Nominal outside diameter of outer ring mm		ΔD_{mp} Deviation of mean outside diameter in a single plane		V_{Dsp} Variation of outside diameter in a single plane (Maximum)	V_{Dmp} Variation of mean outside diameter (Maximum)	K_{ca} Radial runout of outer ring of assembled bearing (Maximum)
Over	Incl.	High	Low			
6	18	0	-25	10	6	15
18	30			12	7	15
30	50			14	8	20
50	80			16	10	25
80	120			19	11	35

Radial Internal Clearance

Radial internal clearance of Cam Followers is shown in Table 5.

Table 5 Radial internal clearance unit: μm

Miniature Type Cam Followers CFS, CFS...W	Identification number			Radial internal clearance	
	Standard Type Cam Followers (1)	Cylindrical Roller Cam Followers	Inch Series Cam Followers	Min.	Max.
CFS1.4 to CFS5	CF 3B to CF 5 B	-	CR 8, CR 8-1, CRH 8-1, CRH 9	3	17
CFS6	CF 6B	-	CR10, CR10-1, CRH10-1, CRH11	5	20
-	CF 8 to CF 12-1 CFKR30 to CFKR32	-	CR12 to CR22, CRH12 to CRH22	5	25
-	CF 16 to CF 20-1 CFKR22 to CFKR52	-	CR24 to CR36, CRH24 to CRH36	10	30
-	CF 24 to CF 30-2 CFKR62 to CFKR90	-	CR48, CRH40 to CRH56	10	40
-	-	-	CRH64	15	50
-	-	NUCF10 B to NUCF24 B	-	20	45
-	-	NUCF24-1B to NUCF30-2B	-	25	50

Note (1) Applicable for all Cam Followers other than Miniature Type Cam Followers, Cylindrical Roller Cam Followers and Inch Series Cam Followers.

Fit

Recommended fit of the Cam Followers stud and mounting hole is shown in Table 6 and dimensional tolerances of mounting hole are shown in Table 7, respectively. Since the Cam Follower is supported in a cantilever position, the mounting hole diameter should be prepared without play between the stud and the hole especially when heavy shock loads are applied.

Table 6 Recommended fit

Model of bearing	Tolerance class of mounting hole for stud
Miniature Type Cam Followers CFS, CFS...W	H6
Standard Type Cam Followers (1)	H7
Inch Series Cam Followers	F7

Note (1) Applicable for Cam Followers other than Miniature Type Cam Followers and Inch Series Cam Followers.

Table 7 Dimensional tolerances of mounting hole unit: μm

Classification of diameter mm		F7		H6		H7	
Over	Incl.	High	Low	High	Low	High	Low
-	3	+16	+ 6	+ 6	0	+10	0
3	6	+22	+10	+ 8	0	+12	0
6	10	+28	+13	+ 9	0	+15	0
10	18	+34	+16	+11	0	+18	0
18	30	+41	+20	+13	0	+21	0
30	40	+50	+25	+16	0	+25	0
40	50						

Track Capacity

Track capacity is defined as the load which can be continuously applied on a Cam Follower placed on a steel cam guide surface without causing deformation or indentation on the cam guide surface when the outer ring of the Roller Follower makes contact with the mating cam guide surface (plane). Track capacities shown in the dimension table are values on the assumption that hardness of the mating member material is 40HRC (tensile strength: 1250 N/mm²) and if hardness is not 40HRC, these values must be multiplied by track capacity factors shown in Table 8. If lubrication between the outer ring and the mating cam guide surface is insufficient, seizure and/or wear may occur depending on the operating conditions. Therefore, attention must be paid to lubrication and surface roughness of the mating cam guide especially for high-speed rotations such as cam mechanisms.

Table 8 Track capacity factor

Hardness HRC	Tensile strength N/mm ²	Track capacity factor	
		Crowned outer ring	Cylindrical outer ring
20	760	0.22	0.37
25	840	0.31	0.46
30	950	0.45	0.58
35	1 080	0.65	0.75
38	1 180	0.85	0.89
40	1 250	1.00	1.00
42	1 340	1.23	1.15
44	1 435	1.52	1.32
46	1 530	1.85	1.51
48	1 635	2.27	1.73
50	1 760	2.80	1.99
52	1 880	3.46	2.29
54	2 015	4.21	2.61
56	2 150	5.13	2.97
58	2 290	6.26	3.39

Allowable Rotational Speed

The allowable rotational speed of Cam Followers is affected by mounting and operating conditions. For d_1n value with only pure radial load applied, use values in Table 9 or lower as references. Under actual use conditions, it is recommended to use d_1n , one tenth of indicated values, taking into account the effect of axial load.

C-Lube Cam Followers and Cam Followers with C-Lube Unit mounted, use 10,000 or lower as reference for the d_1n value.

$$d_1n = d_1 \times n$$

where d_1 : Stud diameter of Cam Follower mm
 n : Rotational speed min⁻¹

Table 9 d_1n values of Cam Followers

Model of bearing	Lubrication	Grease lubrication	Oil lubrication
With cage		84 000	140 000
Full complement		42 000	70 000
Cylindrical Roller Cam Followers		66 000	110 000

Lubrication

Bearings with pre-packed grease are shown in Table 10. ALVANIA GREASE S2 (SHOWA SHELL SEKIYU K.K.) is pre-packed as lubrication grease.

For bearings without pre-packed grease, grease should be packed through the oil hole in the stud for use. Operating without lubrication will increase the wear on the rolling contact surfaces and lead to short bearing life.

Table 10 Bearings with pre-packed grease ○: With grease ×: Without grease

Model of bearing Stud dia. d_1 (¹) mm	Type	With cage		Full complement
		Shield type	Sealed type	
Miniature Type Cam Followers	CFS			
Thrust Disk Type Miniature Cam Followers	CFS...W	○	—	○
Standard Type Cam Followers	CF...B	○		—
Double Hex Hole Cam Followers	CFKR			
Thrust Disk Type Cam Followers	CF...WB	○	○	○
Solid Eccentric Stud Type Cam Followers	CFES...B			
Eccentric Type Cam Followers	CFE...B	×		
Cam Follower G	CF...G	○	—	—
C-Lube Cam Followers	CF...WB.../SG (²)	—	×	—
Centralized Lubrication Type Cam Followers	CF-RU1 CF-FU1	—	○	—
Easy Mounting Type Cam Followers	CF-SFU...B	—	○	—
Cylindrical Roller Cam Followers	NUCF...B	—	—	○
Inch Series Cam Followers	CR...B (With hexagon socket) CR (With screwdriver slot)	○	○	○
Inch Series Cam Followers	CRH...B (With hexagon socket) CRH (With screwdriver slot)	—	—	○

Note (¹) For Eccentric Type Cam Followers (CFE), thread diameter G as shown in the dimension table is applicable.

(²) C-Lube, a thermosetting solid-type lubricant, fills the inner space of the bearing.

Oil Hole

The position of oil hole is shown in Table 11.

Perform greasing quietly by fitting a lubrication nozzle shown in Table 12 to a straight type grease gun in JIS B 9808 and pressing the nozzle against the grease nipple or re-greasing fitting.

When the NPT type grease nipple of the special specifications shown in Table 19 and NPB type grease nipple shown in Table 15 are mounted, you may also fill grease by pressing the grease gun without using a supply nozzle specified in Table 12.

In addition, oil cannot be fed for those without oil hole described in Table 11.

Table 11 Location of oil hole

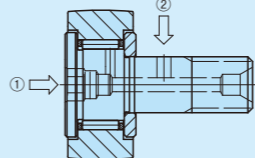

Model of bearing Stud dia. d_1 (¹) mm	Oil hole position	O: With oil hole		
		① Head	② Stud outer diameter section	③ Stud end
Miniature Type Cam Followers	CFS			
Thrust Disk Type Miniature Cam Followers	CFS...W	—	—	—
Standard Type Cam Followers	CF...B	—	—	—
Double Hex Hole Cam Followers	CFKR			
Thrust Disk Type Cam Followers	CF...WB	○ (²)	—	— (³)
Solid Eccentric Stud Type Cam Followers	CFES...B			
Eccentric Type Cam Followers	CFE...B	○ (³)	○	○
Cylindrical Roller Cam Followers	NUCF...B	○ (³)	○	○
Cam Follower G	CF...G	—	—	—
C-Lube Cam Followers	CF...WB.../SG	—	—	—
Centralized Lubrication Type Cam Followers (⁴)	CF-RU1, CF-FU1	○	—	—
Easy Mounting Type Cam Followers	CF-SFU...B	$d_1 \leq 10$	○ (²)	—
		$10 < d_1$	○ (³)	—
Inch Series Cam Followers	CR...B (With hexagon socket)	$d_1 \leq 6.35$	—	—
		$6.35 < d_1$	—	○
Inch Series Cam Followers	CR (With screwdriver slot)	$d_1 \leq 6.35$	○	—
		$6.35 < d_1$	○	○
Inch Series Cam Followers	CRH...B (With hexagon socket)	$d_1 \leq 7.938$	—	—
		$7.938 < d_1$	—	○
Inch Series Cam Followers	CRH (With screwdriver slot)	$d_1 \leq 7.938$	○	—
		$7.938 < d_1$	○	○

Note (¹) For Eccentric Type Cam Followers (CFE), thread diameter G as shown in the dimension table is applicable. However, oil hole on the stud outside surface cannot be used.

(²) Grease can be fed from the re-greasing fitting located inside the hexagon socket on the head.

(³) A grease nipple is incorporated in the hexagon socket at the head. Re-greasing can be done from the stud head and the stud end by press fitting a supplied grease nipple into the oil hole on the stud end.

(⁴) Head and stud end have a tapped hole for piping.

(⁵) Grease can be fed from the grease nipple located inside the hexagon socket on the head.

(⁶) Lubrication from the head part and the stud end is possible for Double Hex Hole Cam Followers (CFKR) only.

Table 12 Models and dimensions of supply nozzle

Model	Dimension	Applicable grease nipple and re-greasing fitting
A-5126T		NPF3 (¹) NPF4-1 (¹) NPF6-1 (¹) Re-greasing fitting (¹)
A-5120R		NPF4-1 (¹) NPF6-1 (¹)
B-5120R		NPF4-1 (¹) NPF6-1 (¹)
A-5120V		
A-5240V		NPT4-1 NPT6-1 NPB2
B-5120V		NPB3 NPB3-1 NPB4
B-5240V		

Note (¹) HSP-3 of YAMADA CORPORATION can also be used.
 Remark The supply nozzles shown in the table can be mounted on the main body of a common grease gun available on the market shown below.

If needed, specify the supply nozzle model and contact **IKO**.

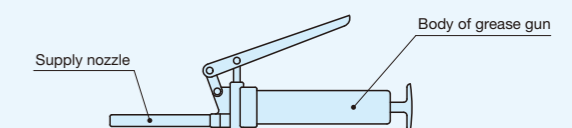

Accessories

Accessories for Cam Followers are shown in Table 13. Grease nipple dimensions are shown in Table 14 and Table 15. Dimensions of plug for unused oil hole and dimensions of plug inserter are shown in Table 16.

Table 13 Accessories

Model of bearing Stud dia. d_1 (¹) mm		Accessories	Grease nipple	Plug	Nut	Spring washer
Miniature Type Cam Followers		CFS	-	-	○	-
Thrust Disk Type Miniature Cam Followers		CFS...W	-	-	○	-
Standard Type Cam Followers		CF...B	- ⁽²⁾	-	○	-
Double Hex Hole Cam Followers		CFKR				
Thrust Disk Type Cam Followers		CF...WB				
Solid Eccentric Stud Type Cam Followers		CFES...B	○	-	○	-
Cylindrical Roller Cam Followers		NUCF...B				
Cam Follower G		CF...G	-	-	○	-
C-Lube Cam Followers		CF...WB.../SG	-	-	○	-
Eccentric Type Cam Followers		CFE...B	○	-	○	○
Centralized Lubrication Type Cam Followers		CF-RU1, CF-FU1	-	-	○	-
Easy Mounting Type Cam Followers		CF-SFU...B	-	-	-	-
Inch Series Cam Followers (With Hexagon Socket)		CR...B	○	○	○	-
Inch Series Cam Followers (With Screwdriver Slot)		CR	○	○	○	-
Inch Series Cam Followers (With Hexagon Socket)		CRH...B	○	○	○	-
Inch Series Cam Followers (With Screwdriver Slot)		CRH	○	○	○	-

○: Supplied

Note (1) For Eccentric Type Cam Followers (CFE), thread diameter G as shown in the dimension table is applicable.

(2) For Double Hex Hole Cam Followers (CFKR) only, a grease nipple is included for the thread side.

Remark The standard grease nipple (brass) is included in the Stainless Steel Made Cam Follower.

We also have the stainless steel grease nipple. Please contact **IKO** and request the product.

Table 14 Dimensions of grease nipple for Standard Type Cam Followers (1)

Identification number	Dimensions of grease nipple mm				Stud dia. d_1 (2) mm	Dimension of inserter mm
	d	D	L	W		
NPF3(3)	3	4	4.5	1.3	10	$d_0^{+0.05/-0.05}$ 4.1
NPF4-1	4	5	5	1.5	12~16	5.3
NPF6-1	6	7	8	2	18~30	7.3

Note (1) Applicable to Cam Followers other than Inch Series Cam Followers.

(2) For Eccentric Type Cam Followers, thread diameter G as shown in the dimension table is applicable.

(3) Only Double Hex Hole Cam Followers (CFKR) sizes 22 and 26 are applicable.

Remark The same grease nipple as the accessory is integrated in the hexagon socket on the head.

Table 15 Dimensions of grease nipple for Inch Series Cam Followers

Identification number	Dimensions of grease nipple mm						Applicable bearing
	d	D	D_1	L	L_1	W	
NPB2	3.18	7.5	6	9	5.5	1.5	CR8 to CR10-1, CRH8-1 to CRH11
NPB3	4.76	7.5	6	10	5.5	1.5	CR12 to CR22, CRH12 to CRH22
NPB3-1	4.76	7.5	6	12.5	5.5	1.55	CR24 to CR36, CRH24 to CRH44
NPB4	6.35	8	6	13	6	2	CR48, CRH48 to CRH64

Table 16 Dimensions of plug for Inch Series Cam Followers

Identification number	Dimensions of plug mm			Dimension of inserter mm	Applicable bearing
	D	t	B		
USB2F	3.18	0.3	3.3	2.3	CR 8 to CR10-1
USB3F	4.76	0.4	4.3	3.7	CR12 to CR36, CRH12 to CRH44
USB4F	6.35	0.5	4.8	5.2	CR48, CRH48 to CRH64

Table 17 Metric series nut dimensions

Model of bearing	Stud dia. d_1 (1)	Nut dimensions mm			
		G	m	s	e
CF CFKR CFES CFE CF...W CF-RU1 CF-FU1 CF...G CF...WB.../SG CFS CFS...W NUCF	1.4	M 1.4×0.3	1.1	3	3.25
	2	M 2 ×0.4	1.6	4	4.6
	2.5	M 2.5×0.45	2	5	5.8
	3	M 3 ×0.5	2.4	5.5	6.4
	4	M 4 ×0.7	3.2	7	8.1
	5	M 5 ×0.8	4	8	9.2
	6	M 6 ×1	5	10	11.5
	8	M 8 ×1.25	6.5	13	15
	10	M10 ×1.0(2) M10 ×1.25	8	17	19.6
	12	M12 ×1.5	10	19	21.9
	16	M16 ×1.5	13	24	27.7
	18	M18 ×1.5	15	27	31.2
	20	M20 ×1.5	16	30	34.6
	24	M24 ×1.5	19	36	41.6
30	M30 ×1.5	24	46	53.1	

Note (1) For Eccentric Type Cam Followers (CFE), thread diameter G as shown in the dimension table is applicable.

(2) Applicable to Double Hex Hole Cam Followers (CFKR).

Table 18 Inch series nut dimensions

Model of bearing	Stud dia. d_1 (inch)	Nut dimensions mm			
		G UNF	m	s	e
CR CRH	4.826	No.10-32	4	8	9.2
	6.35 (1/4)	1/4-28	5.5	10	11.5
	7.938 (5/16)	5/16-24	6.5	12	13.8
	9.525 (3/8)	3/8-24	8	14	16.2
	11.112 (7/16)	7/16-20	10	17	19.5
	12.7 (1/2)	1/2-20	11	19	21.9
	15.875 (5/8)	5/8-18	14	23	26.5
	19.05 (3/4)	3/4-16	16	26	30
	22.225 (7/8)	7/8-14	19	32	37
	25.4 (1)	1 -14UNS	22	36	41.4
	28.575 (1 1/8)	1 1/8-12	24	41	47.1
	31.75 (1 1/4)	1 1/4-12	27	46	53.5
	38.1 (1 1/2)	1 1/2-12	33	55	63.5
	44.45 (1 3/4)	1 3/4-12UN	38	65	75.1
	50.8 (2)	2 -12UN	44	75	86.6

Special Specification

Grease nipple supplied as an accessory can be replaced with the grease nipple shown in Table 19 upon request. With this grease nipple, you may fill grease by pressing the JIS B 9808 straight type grease gun directly onto it without using the supply nozzle in Table 12. When you request it, indicate the identification number with /NP at the end. Note that it is not applicable to Double Hex Hole Cam Followers CFKR.

Example of Identification Number CF 12 BUUR / NP

Table 19 Dimensions of NPT type grease nipple

Identification number	Dimensions of grease nipple mm						Stud dia. d_1 (1) mm
	d	D	D_1	L	L_1	W	
NPT4-1	4	8	6	12	6	2	12 to 16
NPT6-1	6	8	6	14	8	4	18 to 30

Note (1) For Eccentric Type Cam Followers, thread diameter G as shown in the dimension table is applicable.

Table 20 Dimensions with NPT type grease nipple mounted

Identification number	Dimensions mm		Stud dia. d_1 (1) mm
	B_4	B_5	
NPT4-1	6	2	12 to 16
NPT6-1	8	4	18 to 30

Note (1) For Eccentric Type Cam Followers, thread diameter G as shown in the dimension table is applicable.

Operating Temperature Range

Operating temperature range of Cam Followers is -20°C to +120°C. However, note that the maximum allowable temperature varies in models shown in Table 21.

Table 21 Limitation of operating temperature range

Model Stud dia. d_1 mm	Type	With cage	
		Shield type	Sealed type
Miniature Type Cam Followers CFS Thrust Disk Type Miniature Cam Followers CFS...W	$d_1=2$	-20°C to 110°C (1)	-
Standard Type Cam Followers CF...B Thrust Disk Type Cam Followers CF...WB		$d_1=3, 4$	-20°C to 110°C (1)
Standard Type Cam Followers / Stainless Steel Made CF...FB Thrust Disk Type Cam Followers / Stainless Steel Made CF...FWB	$d_1=5$	-20°C to 120°C	-20°C to 80°C
	$3 \leq d_1 \leq 5$	-20°C to 110°C (1)	-20°C to 80°C
C-Lube Cam Followers CF...WB.../SG	$5 \leq d_1 \leq 20$	-	-15°C to 80°C (2)

Note (1) 100°C when used continuously.

(2) Below 60°C is recommended for long use.

Mounting

Notes about mounts

Make the center axis of the mounting hole perpendicular to the moving direction of the Cam Follower and match the side shoulder accurately with the seating surface indicated by dimension f in the table of dimensions. (See Fig. 3)

The chamfered mounting hole should be as small as possible (C0.5 or so).

When mounting Cam Followers, do not hit the flange head of the Cam Follower directly with a hammer, etc. This may lead to a bearing failure such as irregular rotation or cracking.

If the Cam Follower outer ring is not in good contact with the mating running surface then we recommend use of a crowned outer ring type.

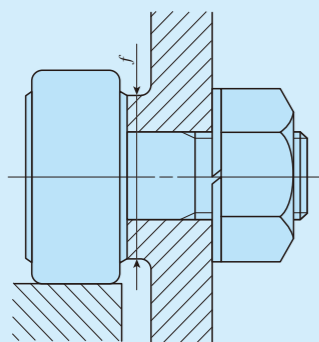



Fig. 3 Height of side face of mounting hole

Notes about oil hole position and loading direction

The  mark on the flange head of the stud indicates the position of the oil hole on the raceway. Avoid locating the oil hole within the loading zone. Otherwise, product life may become shorter. (See Fig. 4.) The hole located in the middle part of the stud perpendicular to the stud center axis is used for greasing or locking.

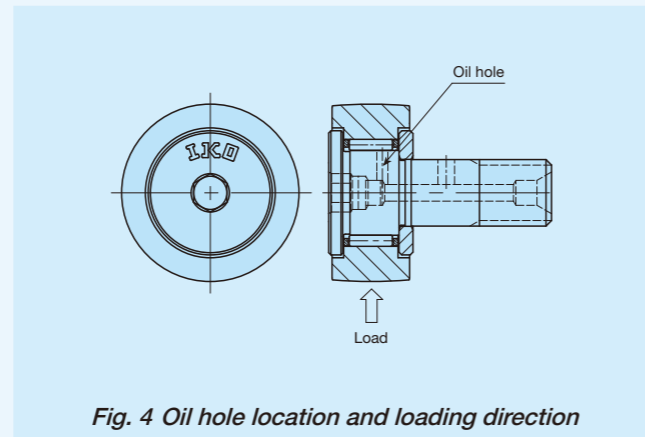

Fig. 4 Oil hole location and loading direction

Notes about mounting methods

1 When mounting Cam Followers, fix in place by holding the hexagon socket or screwdriver slot with a hex wrench or slotted screwdriver and use a wrench to tighten on a nut. (See Fig. 5)

If mounting by turning the hexagon socket or screwdriver slot itself, the hexagon socket or screwdriver slot of the Cam Follower may become damaged.

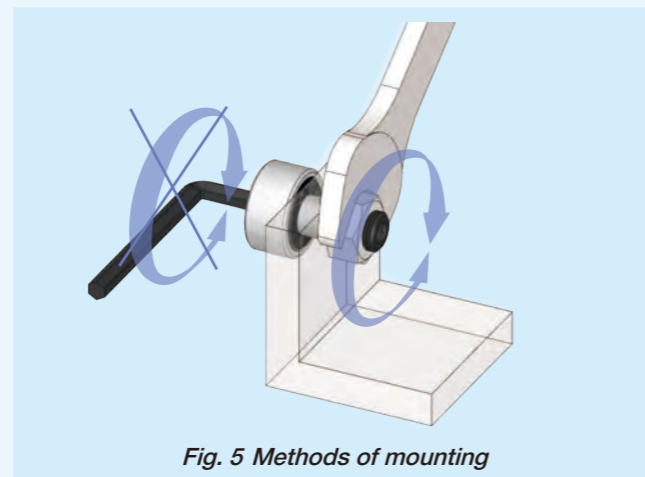

Fig. 5 Methods of mounting

2 When tightening the nut, the tightening torque should not exceed the values shown in the table of dimensions. If the tightening torque is too large, it is possible that the threaded portion of the stud will be broken. When there is a possibility of loosening, a special nut such as a lock nut, spring washer, or self-locking nut should be used.

3 When direct-fixing the Cam Follower without nuts for mounting as shown in Fig. 6, it may be difficult to achieve sufficient tightening torque. If the screw then loosens, stress may concentrate on the thread, causing the stud to break. Such a method is not recommended.

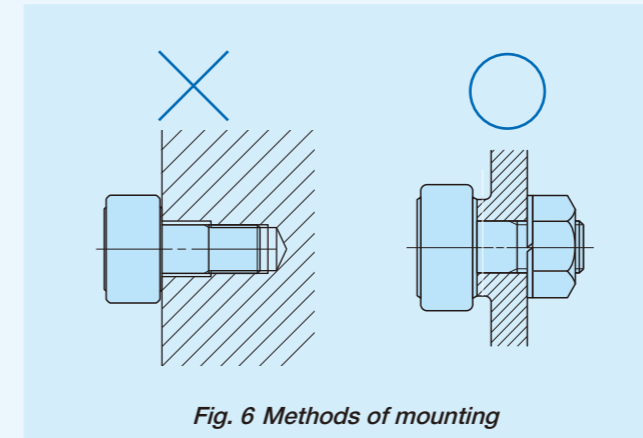
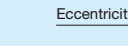

Fig. 6 Methods of mounting

Mounting methods for Solid Eccentric Stud Type Cam Followers

1 For Solid Eccentric Stud Type Cam Followers and Eccentric Type Cam Followers, a reference position for adjustment is defined as the  mark at the side face of stud collar located in the position specified in Fig. 7. Use this as a reference. Adjust the outer ring position by rotating it using the hexagon socket on the stud head. The stud is fixed with a nut and a spring washer, etc. The tightening torque should not exceed the values of maximum tightening torque shown in the table of dimensions.

When shock loads are applied and the adjusted eccentricity has to be ensured, it is recommended to make holes in the housing, stud and eccentric collar, and fix the stud with a dowel pin as shown in Fig. 8. However, studs with diameter 8 mm (eccentric collar diameter: 11 mm) or less are quench-hardened.

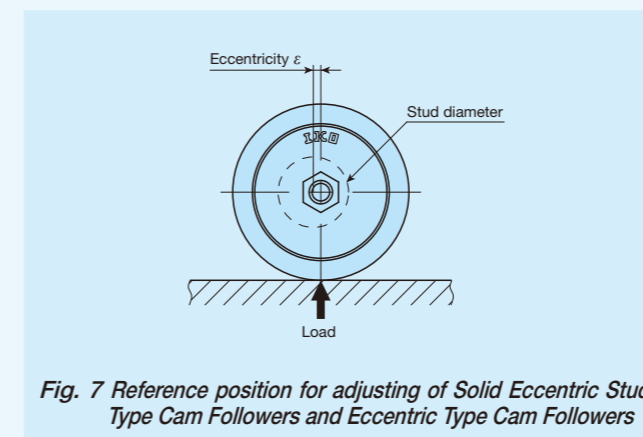

Fig. 7 Reference position for adjusting of Solid Eccentric Stud Type Cam Followers and Eccentric Type Cam Followers

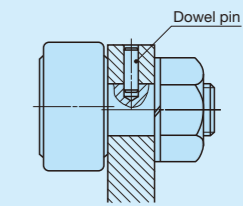

Fig. 8 Mounting examples of Solid Eccentric Stud Type Cam Followers

2 The length of a mounting hole for Eccentric Type Cam Followers must be 0.5 mm or more longer than the B_3 dimensions (eccentric collar width) specified in the dimension table. (See Fig.9)

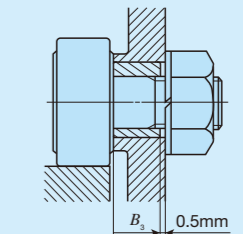

Fig. 9 Length of mounting hole for Eccentric Type Cam Followers

Mounting methods for Easy Mounting Type Cam Followers

For mounting Easy Mounting Type Cam Followers, it is recommended to fix the fixing screw from the upper side to the stepped portion of the stud. (See Fig. 10)

While M5 to M6 screws are generally used as fixing screws, adjust the size used depending on the usage criteria.

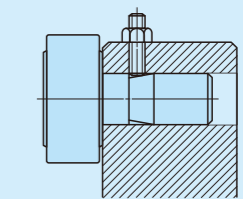

Fig. 10 Mounting examples of Easy Mounting Type Cam Followers

Precautions for Use

- 1 Never clean C-Lube Cam Followers with organic solvent or white kerosene with property of removing fat.
- 2 To rotate the C-Lube Cam Followers normally, apply load of 1% or more of the basic dynamic load rating.

Selectable product specifications

Type of material	No symbol	High carbon steel
	F	Stainless steel
Roller guide method	No symbol	With cage
	V	Full complement
Seal structure	No symbol	Shield type
	UU	Sealed type
Shape of outer ring outside surface	No symbol	Cylindrical outer ring
	R	Crowned outer ring

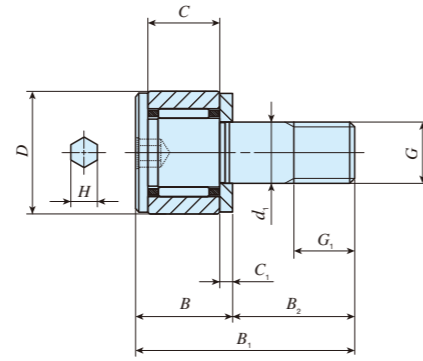

CFS
CFS...F

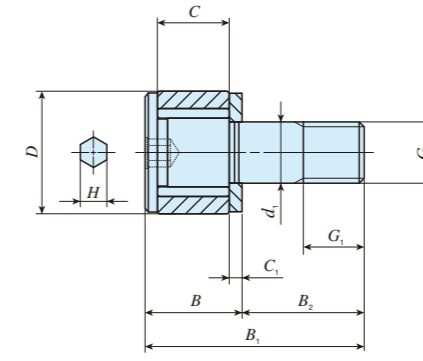

CFS...V
CFS...FV

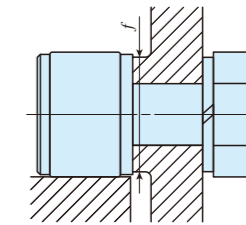

Stud diameter mm	Identification number		Mass (Ref.) g	Boundary dimensions mm											Mounting dimensions f Min. mm	Maximum tightening torque N·cm	Basic dynamic load rating C N	Basic static load rating C ₀ N	Maximum allowable static load N	Track capacity N
	With cage	Full complement		D	C	d ₁	G	G ₁	B	B ₁	B ₂	C ₁	H							
2	CFS 2	—	0.6	4.5	2.5	2	M2 ×0.4	2	4	8	4	0.7	0.9	4.3	9.1	288	202	202	220	
	—	CFS 2 V																		768
2	CFS 2 F	—	1	5	3	2.5	M2.5×0.45	2.5	4.5	9.5	5	0.7	0.9	4.8	18.7	230	161	161	229	
	—	CFS 2 FV																		614
2.5	CFS 2.5	—	2	6	4	3	M3 ×0.5	3	5.5	11.5	6	0.7	1.3	5.8	33.5	629	611	484	485	
	—	CFS 3 V																		1 420
3	CFS 3 F	—	4	8	5	4	M4 ×0.7	4	7	15	8	1.0	1.5	7.7	77.7	504	488	484	799	
	—	CFS 3 FV																		1 140
4	CFS 4	—	7	10	6	5	M5 ×0.8	5	8	18	10	1.0	2	9.6	158	1 120	1 850	1 570	1 210	
	—	CFS 4 V																		3 180
5	CFS 4 F	—	13	12	7	6	M6 ×1	6	9.5	21.5	12	1.2	2.5	11.6	268	897	894	894	1 680	
	—	CFS 4 FV																		1 900
6	CFS 5	—	2	6	4	3	M3 ×0.5	3	5.5	11.5	6	0.7	1.3	5.8	33.5	2 090	2 200	2 150	1 680	
	—	CFS 5 V																		4 610
6	CFS 5 F	—	4	8	5	4	M4 ×0.7	4	7	15	8	1.0	1.5	7.7	77.7	1 250	1 480	1 480	1 680	
	—	CFS 5 FV																		2 540
6	CFS 6	—	7	10	6	5	M5 ×0.8	5	8	18	10	1.0	2	9.6	158	2 090	2 200	2 150	1 680	
	—	CFS 6 V																		4 610
6	CFS 6 F	—	13	12	7	6	M6 ×1	6	9.5	21.5	12	1.2	2.5	11.6	268	1 670	1 760	1 760	1 680	
	—	CFS 6 FV																		3 690

Remarks 1. No oil hole is provided.
2. Provided with pre-packed grease.

Selectable product specifications

Type of material	No symbol	High carbon steel
	F	Stainless steel
Roller guide method	No symbol	With cage
	V	Full complement
Seal structure	No symbol	Shield type
	UU	Sealed type
Shape of outer ring outside surface	No symbol	Cylindrical outer ring
	R	Crowned outer ring

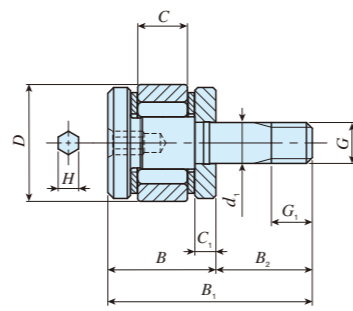

CFS1.4 WV

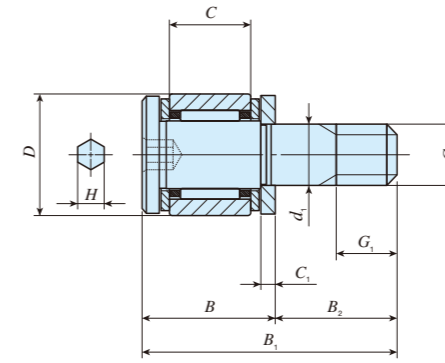

CFS...W
CFS...FW

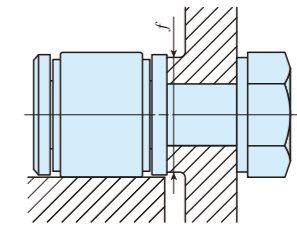

Stud diameter mm	Identification number		Mass (Ref.) g	Boundary dimensions mm											Mounting dimensions <i>f</i> Min. mm	Maximum tightening torque N·cm	Basic dynamic load rating <i>C</i> N	Basic static load rating <i>C</i> ₀ N	Maximum allowable static load N	Track capacity N
	With cage	Full complement		<i>D</i>	<i>C</i>	<i>d</i> ₁	<i>G</i>	<i>G</i> ₁	<i>B</i>	<i>B</i> ₁	<i>B</i> ₂	<i>C</i> ₁	<i>H</i>							
1.4	—	CFS 1.4 WV	0.35	4	1.7	1.4	M1.4×0.3	1.4	3.7	7	3.3	0.7	0.9	3.8	3.0	481	385	105	128	
2	CFS 2 W	—	0.6	4.5	2.5	2	M2 ×0.4	2	4.5	8.5	4	0.7	0.9	4.3	9.1	288	202	194	220	
	CFS 2 FW	—														230	161	161		
2.5	CFS 2.5 W	—	1	5	3	2.5	M2.5×0.45	2.5	5	10	5	0.7	0.9	4.8	18.7	428	351	313	298	
	CFS 2.5 FW	—														342	281	281		
3	CFS 3 W	—	2	6	4	3	M3 ×0.5	3	6.5	12.5	6	0.7	1.3	5.8	33.5	629	611	399	485	
	CFS 3 FW	—														504	488	399		
4	CFS 4 W	—	4	8	5	4	M4 ×0.7	4	8	16	8	1.0	1.5	7.7	77.7	1 120	1 120	785	799	
	CFS 4 FW	—														897	894	785		
5	CFS 5 W	—	7	10	6	5	M5 ×0.8	5	9	19	10	1.0	2	9.6	158	1 570	1 850	1 370	1 210	
	CFS 5 FW	—														1 250	1 480	1 370		
6	CFS 6 W	—	13	12	7	6	M6 ×1	6	10.5	22.5	12	1.2	2.5	11.6	268	2 090	2 200	1 920	1 680	
	CFS 6 FW	—														1 670	1 760	1 760		

Remarks 1. No oil hole is provided.
2. Provided with pre-packed grease.

Selectable product specifications

Type of material	No symbol	High carbon steel
	F	Stainless steel
Roller guide method	No symbol	With cage
	V	Full complement
Seal structure	No symbol	Shield type
	UU	Sealed type
Shape of outer ring outside surface	No symbol	Cylindrical outer ring
	R	Crowned outer ring

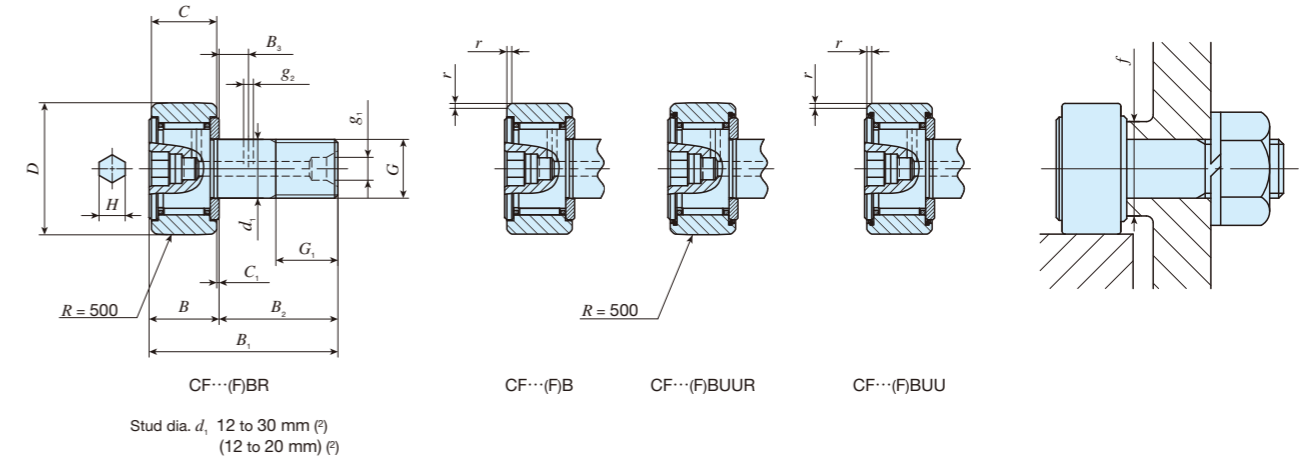
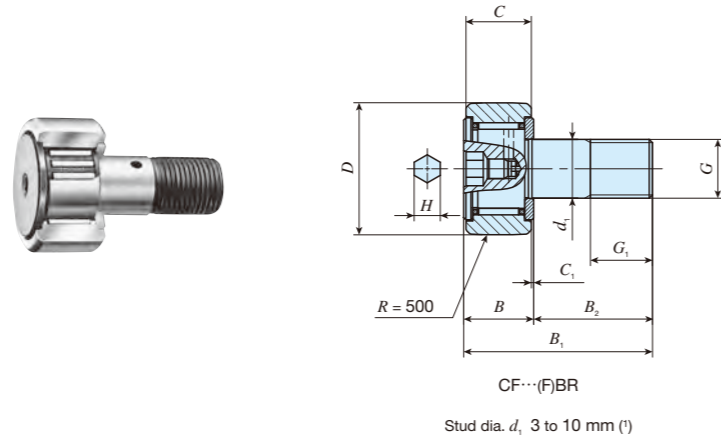

Stud diameter mm	Identification number				Mass (Ref.) g	Boundary dimensions mm															Mounting dimensions f Min. mm	Maximum tightening torque N·m	Basic dynamic load rating N	Basic static load rating N	Maximum allowable static load N	Track capacity	
	Shield type		Sealed type			D	C	d_1	G	G_1	B	B_1	B_2	B_3	C_1	g_1	g_2	H	$r_{s\ min}^{(3)}$	Crown						Cylindrical	
	Crowned outer ring	Cylindrical outer ring	Crowned outer ring	Cylindrical outer ring																							Crowned outer ring
3	CF 3 BR	CF 3 B	CF 3 BUUR	CF 3 BUU	4.3	10	7	3	M 3×0.5	5	8	17	9	—	0.5	—	—	2	0.2	6.8	0.34	1 500	1 020	384	542	1 360	
	CF 3 FBR	CF 3 FB	CF 3 FBUUR	CF 3 FBUU	4.3	10	7	3	M 3×0.5	5	8	17	9	—	0.5	—	—	2	0.2	6.8	0.34	1 200	813	384	542	1 360	
4	CF 4 BR	CF 4 B	CF 4 BUUR	CF 4 BUU	7.4	12	8	4	M 4×0.7	6	9	20	11	—	0.5	—	—	2.5	0.3	8.3	0.78	2 070	1 590	834	712	1 790	
	CF 4 FBR	CF 4 FB	CF 4 FBUUR	CF 4 FBUU	7.4	12	8	4	M 4×0.7	6	9	20	11	—	0.5	—	—	2.5	0.3	8.3	0.78	1 650	1 270	834	712	1 790	
5	CF 5 BR	CF 5 B	CF 5 BUUR	CF 5 BUU	10.3	13	9	5	M 5×0.8	7.5	10	23	13	—	0.5	—	—	3	0.3	9.3	1.6	2 520	2 140	1 260	794	2 210	
	CF 5 FBR	CF 5 FB	CF 5 FBUUR	CF 5 FBUU	10.3	13	9	5	M 5×0.8	7.5	10	23	13	—	0.5	—	—	3	0.3	9.3	1.6	1 930	1 730	1 260	794	2 210	
6	CF 6 BR	CF 6 B	CF 6 BUUR	CF 6 BUU	18.5	16	11	6	M 6×1	8	12.2max	28.2max	16	—	0.6	—	—	3	0.3	11	2.7	3 660	3 650	1 950	1 040	3 400	
	CF 6 FBR	CF 6 FB	CF 6 FBUUR	CF 6 FBUU	18.5	16	11	6	M 6×1	8	12.2max	28.2max	16	—	0.6	—	—	3	0.3	11	2.7	2 930	2 920	1 950	1 040	3 400	
8	CF 8 BR	CF 8 B	CF 8 BUUR	CF 8 BUU	28.5	19	11	8	M 8×1.25	10	12.2max	32.2max	20	—	0.6	—	—	4	0.3	13	6.5	4 250	4 740	4 620	1 330	4 040	
	CF 8 FBR	CF 8 FB	CF 8 FBUUR	CF 8 FBUU	28.5	19	11	8	M 8×1.25	10	12.2max	32.2max	20	—	0.6	—	—	4	0.3	13	6.5	3 400	3 790	3 790	1 330	4 040	
10	CF 10 BR	CF 10 B	CF 10 BUUR	CF 10 BUU	45	22	12	10	M10×1.25	12	13.2max	36.2max	23	—	0.6	—	—	4	0.3	16	13.8	5 430	6 890	6 890	1 610	4 680	
	CF 10 FBR	CF 10 FB	CF 10 FBUUR	CF 10 FBUU	45	22	12	10	M10×1.25	12	13.2max	36.2max	23	—	0.6	—	—	5	0.3	16	13.8	4 340	5 510	5 510	1 610	4 680	
	CF 10-1 BR	CF 10-1 B	CF 10-1 BUUR	CF 10-1 BUU	60	26	12	10	M10×1.25	12	13.2max	36.2max	23	—	0.6	—	—	4	0.3	16	13.8	5 430	6 890	6 890	2 030	5 530	
	CF 10-1FBR	CF 10-1FB	CF 10-1FBUUR	CF 10-1FBUU	60	26	12	10	M10×1.25	12	13.2max	36.2max	23	—	0.6	—	—	5	0.3	16	13.8	4 340	5 510	5 510	2 030	5 530	
12	CF 12 BR	CF 12 B	CF 12 BUUR	CF 12 BUU	95	30	14	12	M12×1.5	13	15.2max	40.2max	25	6	0.6	4	3	6	0.6	21	21.9	7 910	9 790	9 790	2 470	7 010	
	CF 12 FBR	CF 12 FB	CF 12 FBUUR	CF 12 FBUU	95	30	14	12	M12×1.5	13	15.2max	40.2max	25	6	0.6	4	3	6	0.6	21	21.9	6 330	7 830	7 830	2 470	7 010	
	CF 12-1 BR	CF 12-1 B	CF 12-1 BUUR	CF 12-1 BUU	105	32	14	12	M12×1.5	13	15.2max	40.2max	25	6	0.6	4	3	6	0.6	21	21.9	7 910	9 790	9 790	2 710	7 480	
	CF 12-1FBR	CF 12-1FB	CF 12-1FBUUR	CF 12-1FBUU	105	32	14	12	M12×1.5	13	15.2max	40.2max	25	6	0.6	4	3	6	0.6	21	21.9	6 330	7 830	7 830	2 710	7 480	
16	CF 16 BR	CF 16 B	CF 16 BUUR	CF 16 BUU	170	35	18	16	M16×1.5	17	19.6max	52.1max	32.5	8	0.8	4	3	6	0.6	26	58.5	12 000	18 300	18 300	3 060	11 200	
	CF 16 FBR	CF 16 FB	CF 16 FBUUR	CF 16 FBUU	170	35	18	16	M16×1.5	17	19.6max	52.1max	32.5	8	0.8	4	3	6	0.6	26	58.5	9 620	14 700	14 700	3 060	11 200	
18	CF 18 BR	CF 18 B	CF 18 BUUR	CF 18 BUU	250	40	20	18	M18×1.5	19	21.6max	58.1max	36.5	8	0.8	6	3	8	1	29	86.2	14 800	25 200	25 200	3 660	14 500	
	CF 18 FBR	CF 18 FB	CF 18 FBUUR	CF 18 FBUU	250	40	20	18	M18×1.5	19	21.6max	58.1max	36.5	8	0.8	6	3	8	1	29	86.2	11 800	20 200	20 200	3 660	14 500	
20	CF 20 BR	CF 20 B	CF 20 BUUR	CF 20 BUU	460	52	24	20	M20×1.5	21	25.6max	66.1max	40.5	9	0.8	6	4	8	1	34	119	20 700	34 600	34 600	5 190	23 200	
	CF 20 FBR	CF 20 FB	CF 20 FBUUR	CF 20 FBUU	460	52	24	20	M20×1.5	21	25.6max	66.1max	40.5	9	0.8	6	4	8	1	34	119	16 500	27 700	27 700	5 190	23 200	
	CF 20-1 BR	CF 20-1 B	CF 20-1 BUUR	CF 20-1 BUU	385	47	24	20	M20×1.5	21	25.6max	66.1max	40.5	9	0.8	6	4	8	1	34	119	20 700	34 600	34 600	4 530	21 000	
	CF 20-1FBR	CF 20-1FB	CF 20-1FBUUR	CF 20-1FBUU	385	47	24	20	M20×1.5	21	25.6max	66.1max	40.5	9	0.8	6	4	8	1	34	119	16 500	27 700	27 700	4 530	21 000	
24	CF 24 BR	CF 24 B	CF 24 BUUR	CF 24 BUU	815	62	29	24	M24×1.5	25	30.6max	80.1max	49.5	11	0.8	6	4	12	1	40	215	30 500	52 600	52 000	6 580	34 300	
	CF 24-1 BR	CF 24-1 B	CF 24-1 BUUR	CF 24-1 BUU	1 140	72	29	24	M24×1.5	25	30.6max	80.1max	49.5	11	0.8	6	4	12	1	40	215	30 500	52 600	52 000	8 020	39 800	
30	CF 30 BR	CF 30 B	CF 30 BUUR	CF 30 BUU	1 870	80	35	30	M30×1.5	32	37 max	100 max	63	15	1	6	4	17	1	49	438	45 400	85 100	85 100	9 220	52 700	
	CF 30-1 BR	CF 30-1 B	CF 30-1 BUUR	CF 30-1 BUU	2 030	85	35	30	M30×1.5	32	37 max	100 max	63	15	1	6	4	17	1	49	438	45 400	85 100	85 100	9 990	56 000	
	CF 30-2 BR	CF 30-2 B	CF 30-2 BUUR	CF 30-2 BUU	2 220	90	35	30	M30×1.5	32	37 max	100 max	63	15	1	6	4	17	1	49	438	45 400	85 100	85 100	10 800	59 300	

Note (1) No oil hole is provided if the stud diameter d_1 is 4 mm or less. An oil hole (re-greasing fitting) is provided for the head if the stud diameter d_1 is between 5 and 10 mm.
 (2) An oil hole (grease nipple) is provided for the stud head and an oil hole is provided for the outside surface and the end of the stud.
 (3) Minimum allowable value of chamfer dimension r .
 Remark Grease is pre-packed if the stud diameter d_1 of the shield type is 10 mm or less or if the seal structure is the sealed type. Other models are not provided with pre-packed grease. Perform proper lubrication for use.

Cam Followers

Selectable product specifications

Type of material	No symbol	High carbon steel
	F	Stainless steel
Roller guide method	No symbol	With cage
	V	Full complement
Seal structure	No symbol	Shield type
	UU	Sealed type
Shape of outer ring outside surface	No symbol	Cylindrical outer ring
	R	Crowned outer ring

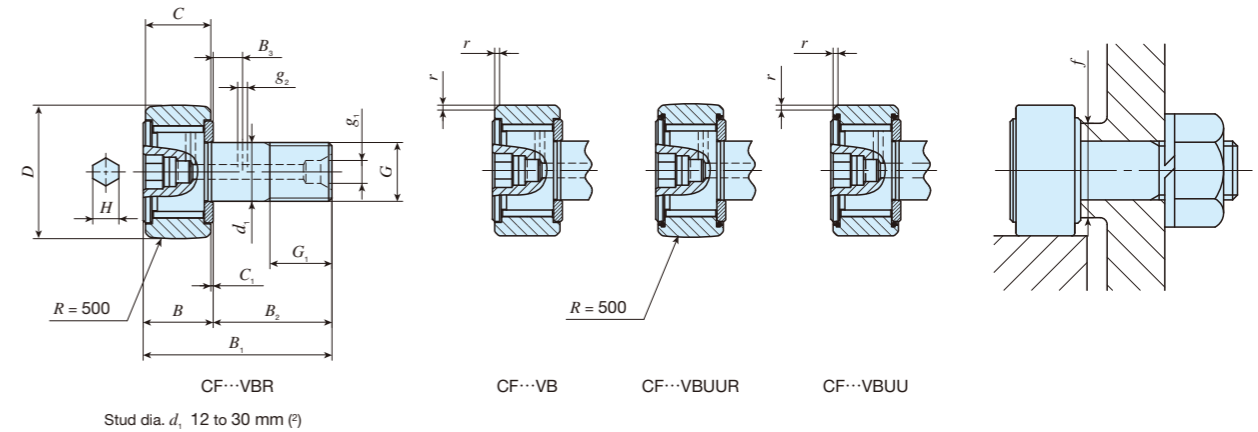
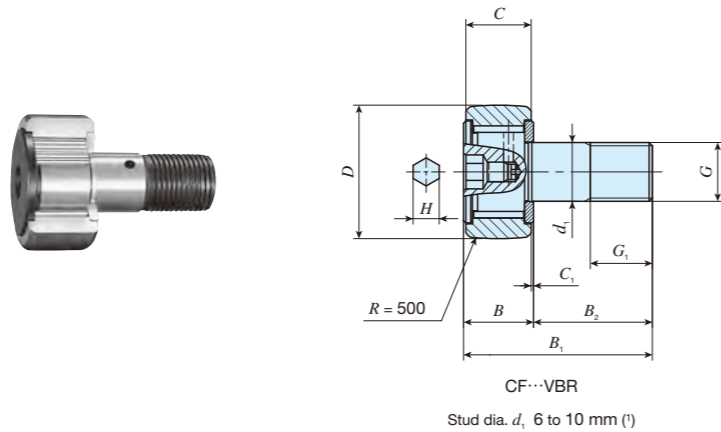

Stud diameter mm	Identification number				Mass (Ref.) g	Boundary dimensions mm															Mounting dimensions f Min. mm	Maximum tightening torque N·m	Basic dynamic load rating C N	Basic static load rating C_0 N	Maximum allowable static load N	Track capacity N	
	Shield type		Sealed type			D	C	d_1	G	G_1	B_{max}	B_{1max}	B_2	B_3	C_1	g_1	g_2	H	$r_{smin}^{(3)}$	Crowned outer ring						Cylindrical outer ring	
	Crowned outer ring	Cylindrical outer ring	Crowned outer ring	Cylindrical outer ring																							
6	CF 6 VBR	CF 6 VB	CF 6 VBUUR	CF 6 VBUU	19	16	11	6	M 6×1	8	12.2	28.2	16	—	0.6	—	—	3	0.3	11	2.7	6 980	8 500	1 950	1 040	3 400	
	CF 6 VBR	CF 6 VB	CF 6 VBUUR	CF 6 VBUU																							
8	CF 8 VBR	CF 8 VB	CF 8 VBUUR	CF 8 VBUU	29	19	11	8	M 8×1.25	10	12.2	32.2	20	—	0.6	—	—	4	0.3	13	6.5	8 170	11 200	4 620	1 330	4 040	
	CF 8 VBR	CF 8 VB	CF 8 VBUUR	CF 8 VBUU																							
10	CF 10 VBR	CF 10 VB	CF 10 VBUUR	CF 10 VBUU	46	22	12	10	M10×1.25	12	13.2	36.2	23	—	0.6	—	—	4	0.3	16	13.8	9 570	14 500	8 650	1 610	4 680	
	CF 10-1 VBR	CF 10-1 VB	CF 10-1 VBUUR	CF 10-1 VBUU																							
12	CF 12 VBR	CF 12 VB	CF 12 VBUUR	CF 12 VBUU	97	30	14	12	M12×1.5	13	15.2	40.2	25	6	0.6	4	3	6	0.6	21	21.9	13 500	19 700	13 200	2 470	7 010	
	CF 12-1 VBR	CF 12-1 VB	CF 12-1 VBUUR	CF 12-1 VBUU																							
16	CF 16 VBR	CF 16 VB	CF 16 VBUUR	CF 16 VBUU	173	35	18	16	M16×1.5	17	19.6	52.1	32.5	8	0.8	4	3	6	0.6	26	58.5	20 700	37 600	23 200	3 060	11 200	
	CF 16 VBR	CF 16 VB	CF 16 VBUUR	CF 16 VBUU																							
18	CF 18 VBR	CF 18 VB	CF 18 VBUUR	CF 18 VBUU	255	40	20	18	M18×1.5	19	21.6	58.1	36.5	8	0.8	6	3	8	1	29	86.2	25 300	51 300	31 100	3 660	14 500	
	CF 18 VBR	CF 18 VB	CF 18 VBUUR	CF 18 VBUU																							
20	CF 20 VBR	CF 20 VB	CF 20 VBUUR	CF 20 VBUU	465	52	24	20	M20×1.5	21	25.6	66.1	40.5	9	0.8	6	4	8	1	34	119	33 200	64 500	37 500	5 190	23 200	
	CF 20-1 VBR	CF 20-1 VB	CF 20-1 VBUUR	CF 20-1 VBUU																							
24	CF 24 VBR	CF 24 VB	CF 24 VBUUR	CF 24 VBUU	820	62	29	24	M24×1.5	25	30.6	80.1	49.5	11	0.8	6	4	12	1	40	215	46 600	92 000	52 000	6 580	34 300	
	CF 24-1 VBR	CF 24-1 VB	CF 24-1 VBUUR	CF 24-1 VBUU																							
30	CF 30 VBR	CF 30 VB	CF 30 VBUUR	CF 30 VBUU	1 870	80	35	30	M30×1.5	32	37	100	63	15	1	6	4	17	1	49	438	67 700	144 000	85 900	9 220	52 700	
	CF 30-1 VBR	CF 30-1 VB	CF 30-1 VBUUR	CF 30-1 VBUU																							
	CF 30-2 VBR	CF 30-2 VB	CF 30-2 VBUUR	CF 30-2 VBUU	2 030	85	35	30	M30×1.5	32	37	100	63	15	1	6	4	17	1	49	438	67 700	144 000	85 900	9 990	56 000	
					2 220	90	35	30	M30×1.5	32	37	100	63	15	1	6	4	17	1	49	438	67 700	144 000	85 900	10 800	59 300	

Note ⁽¹⁾ An oil hole (re-greasing fitting) is provided for the stud head.

⁽²⁾ An oil hole (grease nipple) is provided for the stud head and an oil hole is provided for the outside surface and the end of the stud.

⁽³⁾ Minimum allowable value of chamfer dimension r .

Remark Provided with pre-packed grease.

Selectable product specifications

Type of material	No symbol	High carbon steel
	F	Stainless steel
Roller guide method	No symbol	With cage
	V	Full complement
Seal structure	No symbol	Shield type
	UU	Sealed type
Shape of outer ring outside surface	No symbol	Cylindrical outer ring
	R	Crowned outer ring

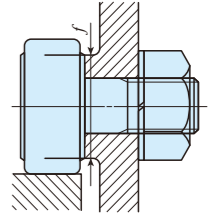
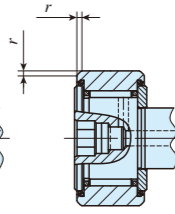
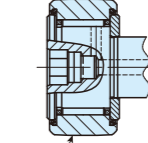
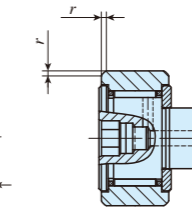
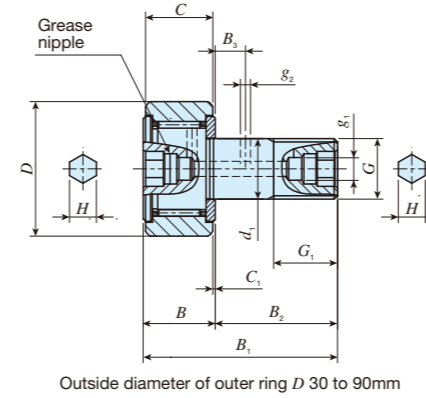
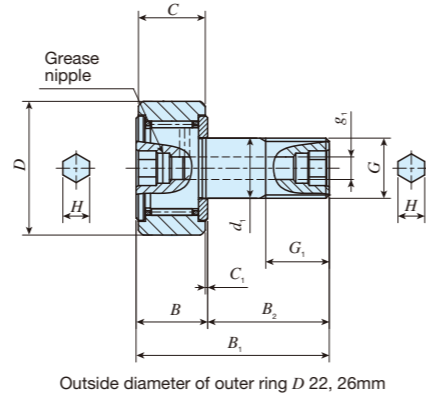

CFKR

CFKR...UUR

CFKR...UU

Stud diameter mm	Identification number ⁽¹⁾				Mass (Ref.) g	Boundary dimensions mm															Mounting dimensions f mm	Maximum tightening torque N·m	Basic dynamic load rating C N	Basic static load rating C ₀ N	Maximum allowable static load N	Track capacity N				
	Shield type		Sealed type			D	C	d ₁	G	G ₁	B max	B ₁ max	B ₂	B ₃	C ₁	g ₁	g ₂	H	r _{s min} ⁽²⁾	Min. mm						N	N	N	Crowned outer ring	Cylindrical outer ring
	Crowned outer ring	Cylindrical outer ring	Crowned outer ring	Cylindrical outer ring																										
10	CFKR 22 R	CFKR 22	CFKR 22 UUR	CFKR 22 UU	43	22	12	10	M10×1.0	12									16	13.0	5 430	6 890	6 890	1 610	4 680					
	CFKR 26 R	CFKR 26	CFKR 26 UUR	CFKR 26 UU	58	26	14	12	M12×1.5	13									21	21.9	7 910	9 790	9 790	2 030	5 530					
12	CFKR 30 R	CFKR 30	CFKR 30 UUR	CFKR 30 UU	94	30	14	12	M12×1.5	13									21	21.9	7 910	9 790	9 790	2 470	7 010					
	CFKR 32 R	CFKR 32	CFKR 32 UUR	CFKR 32 UU	104	32	14	12	M12×1.5	13									21	21.9	7 910	9 790	9 790	2 710	7 480					
16	CFKR 35 R	CFKR 35	CFKR 35 UUR	CFKR 35 UU	165	35	18	16	M16×1.5	17									26	58.5	12 000	18 300	18 300	3 060	11 200					
18	CFKR 40 R	CFKR 40	CFKR 40 UUR	CFKR 40 UU	248	40	20	18	M18×1.5	19									29	86.2	14 800	25 200	25 200	3 660	14 500					
20	CFKR 47 R	CFKR 47	CFKR 47 UUR	CFKR 47 UU	378	47	24	20	M20×1.5	21									34	119	20 700	34 600	34 600	4 530	21 000					
	CFKR 52 R	CFKR 52	CFKR 52 UUR	CFKR 52 UU	453	52	24	20	M20×1.5	21									34	119	20 700	34 600	34 600	5 190	23 200					
24	CFKR 62 R	CFKR 62	CFKR 62 UUR	CFKR 62 UU	795	62	29	24	M24×1.5	25									40	215	30 500	52 600	52 000	6 580	34 300					
	CFKR 72 R	CFKR 72	CFKR 72 UUR	CFKR 72 UU	1 120	72	29	24	M24×1.5	25									40	215	30 500	52 600	52 000	8 020	39 800					
30	CFKR 80 R	CFKR 80	CFKR 80 UUR	CFKR 80 UU	1 860	80	35	30	M30×1.5	32									49	438	45 400	85 100	85 100	9 220	52 700					
	CFKR 85 R	CFKR 85	CFKR 85 UUR	CFKR 85 UU	2 020	85	35	30	M30×1.5	32									49	438	45 400	85 100	85 100	9 990	56 000					
	CFKR 90 R	CFKR 90	CFKR 90 UUR	CFKR 90 UU	2 210	90	35	30	M30×1.5	32									49	438	45 400	85 100	85 100	10 800	59 300					

Note ⁽¹⁾ The identification number indicates the outer ring outside diameter.

⁽²⁾ Minimum allowable value of chamfer dimension r.

Remark Shield type models are not provided with pre-packed grease. Perform proper lubrication for use.

Selectable product specifications

Type of material	No symbol	High carbon steel
	F	Stainless steel
Roller guide method	No symbol	With cage
	V	Full complement
Seal structure	No symbol	Shield type
	UU	Sealed type
Shape of outer ring outside surface	No symbol	Cylindrical outer ring
	R	Crowned outer ring

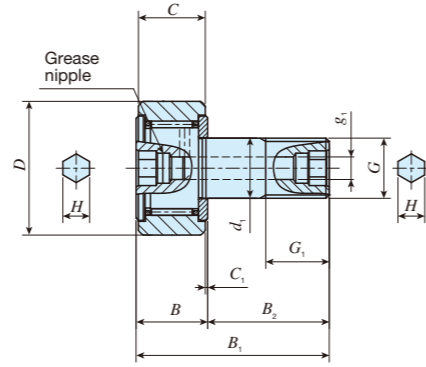

Outside diameter of outer ring D 22, 26mm

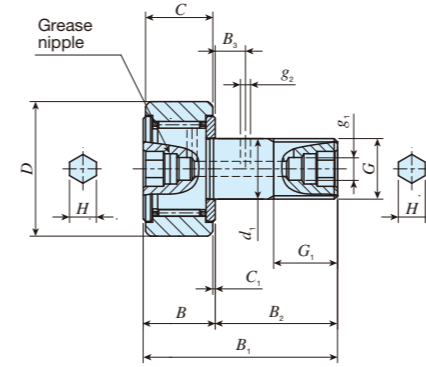

Outside diameter of outer ring D 30 to 90mm

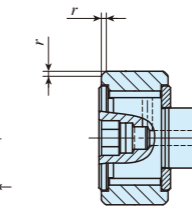

CFKR...V

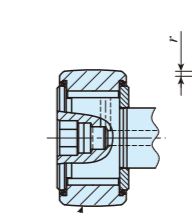

CFKR...VUUR

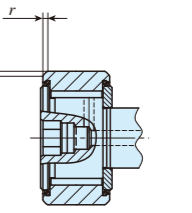

CFKR...VUU

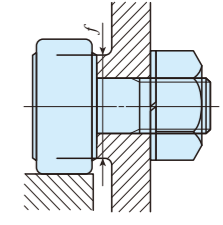

Stud diameter mm	Identification number ⁽¹⁾				Mass (Ref.) g	Boundary dimensions mm														Mounting dimensions f Min. mm	Maximum tightening torque N·m	Basic dynamic load rating C N	Basic static load rating C ₀ N	Maximum allowable static load N	Track capacity N	
	Shield type		Sealed type			D	C	d ₁	G	G ₁	B max	B ₁ max	B ₂	B ₃	C ₁	g ₁	g ₂	H	r _{s min} ⁽²⁾						Crowned outer ring	Cylindrical outer ring
	Crowned outer ring	Cylindrical outer ring	Crowned outer ring	Cylindrical outer ring																						
10	CFKR 22 VR	CFKR 22 V	CFKR 22 VUUR	CFKR 22 VUU	44	22	12	10	M10×1.0	12												1 610	4 680			
	CFKR 26 VR	CFKR 26 V	CFKR 26 VUUR	CFKR 26 VUU	59	26	14	12	M12×1.5	13	13.2	36.2	23	—	0.6	3	—	5	0.3	16	13.0	9 570	14 500	2 030	5 530	
12	CFKR 30 VR	CFKR 30 V	CFKR 30 VUUR	CFKR 30 VUU	96	30	14	12	M12×1.5	13												2 470	7 010			
	CFKR 32 VR	CFKR 32 V	CFKR 32 VUUR	CFKR 32 VUU	106	32	14	12	M12×1.5	13	15.2	40.2	25	6	0.6	4	3	6	0.6	21	21.9	13 500	19 700	2 710	7 480	
16	CFKR 35 VR	CFKR 35 V	CFKR 35 VUUR	CFKR 35 VUU	168	35	18	16	M16×1.5	17												3 060	11 200			
18	CFKR 40 VR	CFKR 40 V	CFKR 40 VUUR	CFKR 40 VUU	253	40	20	18	M18×1.5	19												3 660	14 500			
20	CFKR 47 VR	CFKR 47 V	CFKR 47 VUUR	CFKR 47 VUU	383	47	24	20	M20×1.5	21												4 530	21 000			
	CFKR 52 VR	CFKR 52 V	CFKR 52 VUUR	CFKR 52 VUU	458	52	24	20	M20×1.5	21	25.6	66.1	40.5	9	0.8	6	4	10	1	34	119	33 200	64 500	5 190	23 200	
24	CFKR 62 VR	CFKR 62 V	CFKR 62 VUUR	CFKR 62 VUU	800	62	29	24	M24×1.5	25												6 580	34 300			
	CFKR 72 VR	CFKR 72 V	CFKR 72 VUUR	CFKR 72 VUU	1 120	72	29	24	M24×1.5	25	30.6	80.1	49.5	11	0.8	6	4	14	1	40	215	46 600	92 000	8 020	39 800	
30	CFKR 80 VR	CFKR 80 V	CFKR 80 VUUR	CFKR 80 VUU	1 860	80	35	30	M30×1.5	32												9 220	52 700			
	CFKR 85 VR	CFKR 85 V	CFKR 85 VUUR	CFKR 85 VUU	2 020	85	35	30	M30×1.5	32	37	100	63	15	1	6	4	14	1	49	438	67 700	144 000	9 990	56 000	
	CFKR 90 VR	CFKR 90 V	CFKR 90 VUUR	CFKR 90 VUU	2 210	90	35	30	M30×1.5	32	37	100	63	15	1	6	4	14	1	49	438	67 700	144 000	10 800	59 300	

Note ⁽¹⁾ The identification number indicates the outer ring outside diameter.

⁽²⁾ Minimum allowable value of chamfer dimension *r*.

Remark Provided with pre-packed grease.

Selectable product specifications

Type of material	No symbol	High carbon steel
	F	Stainless steel
Roller guide method	No symbol	With cage
	V	Full complement
Seal structure	No symbol	Shield type
	UU	Sealed type
Shape of outer ring outside surface	No symbol	Cylindrical outer ring
	R	Crowned outer ring

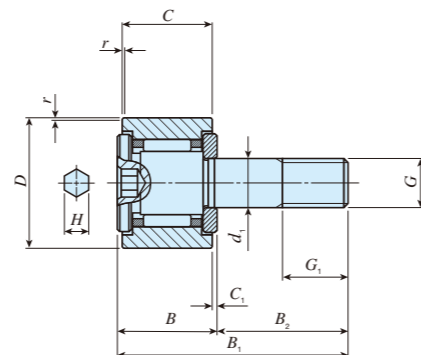

CF...G

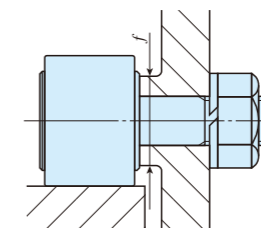

Stud diameter mm	Identification number With cage	Mass (Ref.) g	Boundary dimensions mm												Mounting dimensions f Min. mm	Maximum tightening torque N·m	Basic dynamic load rating C N	Basic static load rating C ₀ N	Maximum allowable static load N	Track capacity N	
			D	C	d ₁	G	G ₁	B _{max}	B _{1max}	B ₂	C ₁	H	r _{s min} ⁽¹⁾								
6	CF 6 G	19.5	16	11	6	M 6 ×1	8	12.2	28.2			16	0.6	3	0.3	11	2.7	3 660	3 650	1 950	3 400
8	CF 8 G	29.5	19	11	8	M 8 ×1.25	10	12.2	32.2			20	0.6	4	0.3	13	6.5	4 250	4 740	4 620	4 040
10	CF 10 G	47.5	22	12	10	M10 ×1.25	12	13.2	36.2			23	0.6	4	0.3	16	13.8	5 430	6 890	6 890	4 680
	CF 10-1 G	61.5	26	12	10	M10 ×1.25	12	13.2	36.2			23	0.6	4	0.3	16	13.8	5 430	6 890	6 890	5 530
12	CF 12 G	95.0	30	14	12	M12 ×1.5	13	15.2	40.2			25	0.6	6	0.6	21	23.9	7 910	9 790	9 790	7 010
	CF 12-1 G	105	32	14	12	M12 ×1.5	13	15.2	40.2			25	0.6	6	0.6	21	23.9	7 910	9 790	9 790	7 480
16	CF 16 G	175	35	18	16	M16 ×1.5	17	19.6	52.1			32.5	0.8	6	0.6	26	61.1	12 000	18 300	18 300	11 200
18	CF 18 G	255	40	20	18	M18 ×1.5	19	21.6	58.1			36.5	0.8	8	1	29	89.2	14 800	25 200	25 200	14 500
20	CF 20 G	470	52	24	20	M20 ×1.5	21	25.6	66.1			40.5	0.8	8	1	34	125	20 700	34 600	34 600	23 200
	CF 20-1 G	400	47	24	20	M20 ×1.5	21	25.6	66.1			40.5	0.8	8	1	34	125	20 700	34 600	34 600	21 000

Note (1) Minimum allowable value of chamfer dimension r.

Remarks 1. This bearing cannot be re-lubricated due to its structure. If re-lubrication is necessary, please use **IKO** Standard Type Cam Followers.

2. Provided with pre-packed grease.

Selectable product specifications

Type of material	No symbol	High carbon steel
	F	Stainless steel
Roller guide method	No symbol	With cage
	V	Full complement
Seal structure	No symbol	Shield type
	UU	Sealed type
Shape of outer ring outside surface	No symbol	Cylindrical outer ring
	R	Crowned outer ring

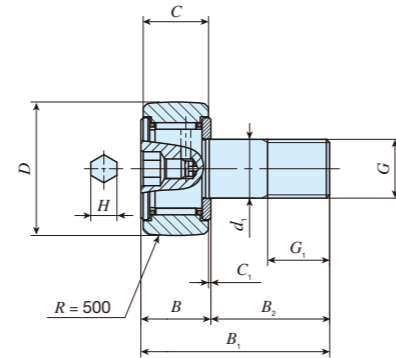
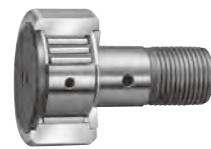

CF...WBR

Stud dia. d_1 3 to 10 mm ⁽¹⁾
(3 to 5 mm) ⁽¹⁾

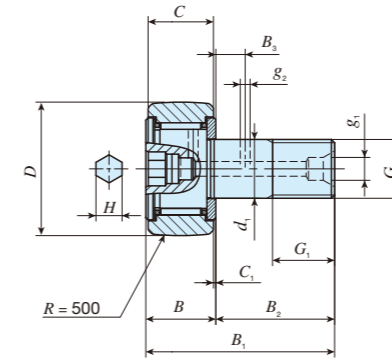

CF...WBR

Stud dia. d_1 12 to 20 mm ⁽²⁾

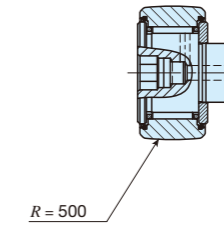

CF...(F)WBUUR

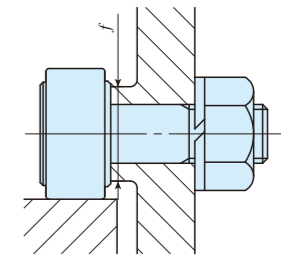

Stud diameter mm	Identification number		Mass (Ref.) g	Boundary dimensions mm															Mounting dimensions f Min. mm	Maximum tightening torque N·m	Basic dynamic load rating C N	Basic static load rating C_0 N	Maximum allowable static load N	Track capacity N
	Shield type	Sealed type		D	C	d_1	G	G_1	B	B_1	B_2	B_3	C_1	g_1	g_2	H								
3	CF 3 WBR	CF 3 WBUUR	4.3	10	7	3	M 3×0.5	5	8	17	9	—	0.5	—	—	2	6.8	0.34	1 500	1 020	384	542		
	CF 3 FWBR	CF 3 FWBUUR	4.3	10	7	3	M 3×0.5	5	8	17	9	—	0.5	—	—	2	6.8	0.34	1 200	813	384	542		
4	CF 4 WBR	CF 3 WBUUR	7.4	12	8	4	M 4×0.7	6	9	20	11	—	0.5	—	—	2.5	8.3	0.78	2 070	1 590	834	712		
	CF 4 FWBR	CF 3 FWBUUR	7.4	12	8	4	M 4×0.7	6	9	20	11	—	0.5	—	—	2.5	8.3	0.78	1 650	1 270	834	712		
5	CF 5 WBR	CF 5 WBUUR	10.3	13	9	5	M 5×0.8	7.5	10	23	13	—	0.5	—	—	3	9.3	1.6	2 520	2 140	1 260	794		
	CF 5 FWBR	CF 5 FWBUUR	10.3	13	9	5	M 5×0.8	7.5	10	23	13	—	0.5	—	—	3	9.3	1.6	1 930	1 730	1 260	794		
6	CF 6 WBR	CF 6 WBUUR	18.5	16	11	6	M 6×1	8	12.2max	28.2max	16	—	0.6	—	—	3	11	2.7	3 660	3 650	1 950	1 040		
8	CF 8 WBR	CF 8 WBUUR	28.5	19	11	8	M 8×1.25	10	12.2max	32.2max	20	—	0.6	—	—	4	13	6.5	4 250	4 740	4 620	1 330		
10	CF 10 WBR	CF 10 WBUUR	45	22	12	10	M10×1.25	12	13.2max	36.2max	23	—	0.6	—	—	4	16	13.8	5 430	6 890	6 890	1 610		
	CF 10-1 WBR	CF 10-1 WBUUR	60	26	12	10	M10×1.25	12	13.2max	36.2max	23	—	0.6	—	—	4	16	13.8	5 430	6 890	6 890	2 030		
12	CF 12 WBR	CF 12 WBUUR	95	30	14	12	M12×1.5	13	15.2max	40.2max	25	6	0.6	4	3	6	21	21.9	7 910	9 790	9 790	2 470		
	CF 12-1 WBR	CF 12-1 WBUUR	105	32	14	12	M12×1.5	13	15.2max	40.2max	25	6	0.6	4	3	6	21	21.9	7 910	9 790	9 790	2 710		
16	CF 16 WBR	CF 16 WBUUR	170	35	18	16	M16×1.5	17	19.6max	52.1max	32.5	8	0.8	4	3	6	26	58.5	12 000	18 300	18 300	3 060		
18	CF 18 WBR	CF 18 WBUUR	250	40	20	18	M18×1.5	19	21.6max	58.1max	36.5	8	0.8	6	3	8	29	86.2	14 800	25 200	25 200	3 660		
20	CF 20 WBR	CF 20 WBUUR	460	52	24	20	M20×1.5	21	25.6max	66.1max	40.5	9	0.8	6	4	8	34	119	20 700	34 600	34 600	5 190		
	CF 20-1 WBR	CF 20-1 WBUUR	385	47	24	20	M20×1.5	21	25.6max	66.1max	40.5	9	0.8	6	4	8	34	119	20 700	34 600	34 600	4 530		

Note ⁽¹⁾ No oil hole is provided if the stud diameter d_1 is 4 mm or less. An oil hole (re-greasing fitting) is provided for the head if the stud diameter d_1 is between 5 and 10 mm.

⁽²⁾ An oil hole (grease nipple) is provided for the stud head and an oil hole is provided for the outside surface and the end of the stud.

Remark Grease is pre-packed if the stud diameter d_1 of the shield type is 10 mm or less or if the seal structure is the sealed type. Other models are not provided with pre-packed grease. Perform proper lubrication for use.

Selectable product specifications

Type of material	No symbol	High carbon steel
	F	Stainless steel
Roller guide method	No symbol	With cage
	V	Full complement
Seal structure	No symbol	Shield type
	UU	Sealed type
Shape of outer ring outside surface	No symbol	Cylindrical outer ring
	R	Crowned outer ring

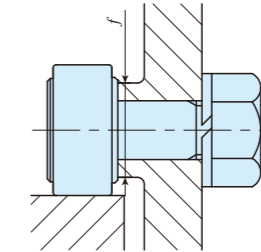
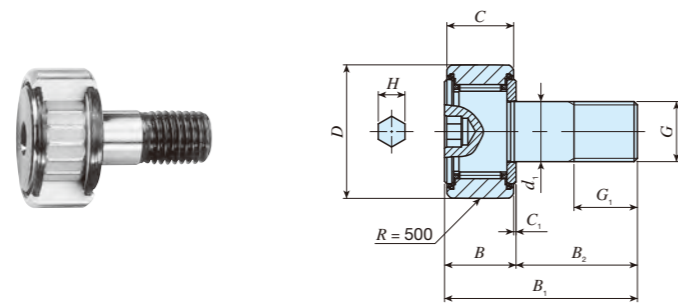

Stud diameter mm	Identification number	Mass (Ref.) g	Boundary dimensions mm											Mounting dimensions f Min. mm	Maximum tightening torque N·m	Basic dynamic load rating C N	Basic static load rating C ₀ N	Maximum allowable static load N	Track capacity N	
			D	C	d ₁	G	G ₁	B	B ₁	B ₂	C ₁	H								
5	CF 5 WBUUR/SG	10.3	13	9	5	M 5×0.8	7.5	10	23						9.3	1.6	2 520	2 140	1 260	794
6	CF 6 WBUUR/SG	18.5	16	11	6	M 6×1	8	12.2 max	28.2 max						11	2.7	3 660	3 650	1 950	1 040
8	CF 8 WBUUR/SG	28.5	19	11	8	M 8×1.25	10	12.2 max	32.2 max						13	6.5	4 250	4 740	4 620	1 330
10	CF 10 WBUUR/SG	45	22	12	10	M10×1.25	12	13.2 max	36.2 max						16	13.8	5 430	6 890	6 890	1 610
	CF 10-1 WBUUR/SG	60	26	12	10	M10×1.25	12	13.2 max	36.2 max						16	13.8	5 430	6 890	6 890	2 030
12	CF 12 WBUUR/SG	95	30	14	12	M12×1.5	13	15.2 max	40.2 max						21	21.9	7 910	9 790	9 790	2 470
	CF 12-1 WBUUR/SG	105	32	14	12	M12×1.5	13	15.2 max	40.2 max						21	21.9	7 910	9 790	9 790	2 710
16	CF 16 WBUUR/SG	170	35	18	16	M16×1.5	17	19.6 max	52.1 max						26	58.5	12 000	18 300	18 300	3 060
18	CF 18 WBUUR/SG	250	40	20	18	M18×1.5	19	21.6 max	58.1 max						29	86.2	14 800	25 200	25 200	3 660
20	CF 20 WBUUR/SG	460	52	24	20	M20×1.5	21	25.6 max	66.1 max						34	119	20 700	34 600	34 600	5 190
	CF 20-1 WBUUR/SG	385	47	24	20	M20×1.5	21	25.6 max	66.1 max						34	119	20 700	34 600	34 600	4 530

Remark This bearing cannot be re-lubricated as thermosetting solid-type lubricant C-Lube fills its inner space.

Selectable product specifications

Type of material	No symbol	High carbon steel
	F	Stainless steel
Roller guide method	No symbol	With cage
	V	Full complement
Seal structure	No symbol	Shield type
	UU	Sealed type
Shape of outer ring outside surface	No symbol	Cylindrical outer ring
	R	Crowned outer ring

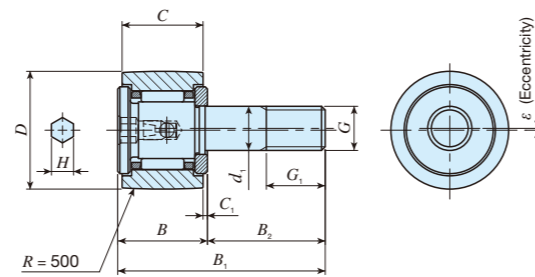
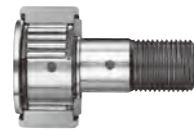

CFES...BR
Stud dia. d_1 6 to 10 mm ⁽¹⁾

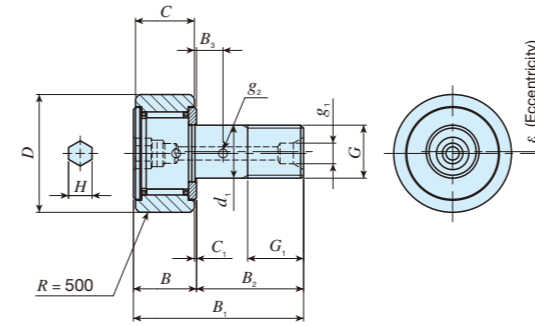

CFES...BR
Stud dia. d_1 12 to 18 mm ⁽²⁾

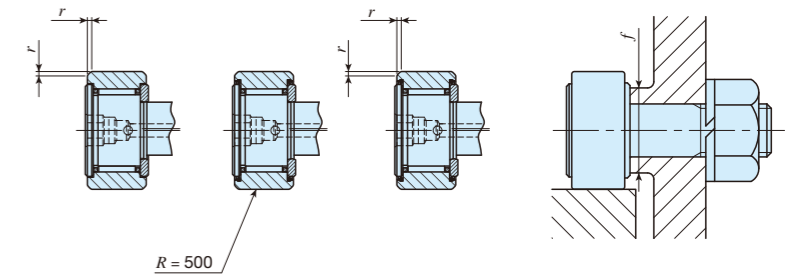

CFES...B CFES...BUUR CFES...BUU

Stud diameter mm	Identification number				Mass (Ref.) g	Boundary dimensions mm														Mounting dimensions f Min. mm	Maximum tightening torque N·m	Basic dynamic load rating C N	Basic static load rating C_0 N	Maximum allowable static load N	Track capacity			
	Shield type		Sealed type			D	C	d_1	G	G_1	B_{max}	B_{1max}	B_2	B_3	C_1	g_1	g_2	H	$r_{smin}^{(3)}$						Eccentricity ϵ	N	Crowned outer ring	Cylindrical outer ring
	Crowned outer ring	Cylindrical outer ring	Crowned outer ring	Cylindrical outer ring																								
6	CFES 6 BR	CFES 6 B	CFES 6 BUUR	CFES 6 BUU	18.5	16	11	6	M 6×1	8	12.2	28.2	16	—	0.6	—	—	3	0.3	0.25	11	2.7	3 660	3 650	1 980	1 040	3 400	
8	CFES 8 BR	CFES 8 B	CFES 8 BUUR	CFES 8 BUU	28.5	19	11	8	M 8×1.25	10	12.2	32.2	20	—	0.6	—	—	4	0.3	0.25	13	6.5	4 250	4 740	4 670	1 330	4 040	
10	CFES 10 BR	CFES 10 B	CFES 10 BUUR	CFES 10 BUU	45	22	12	10	M10×1.25	12	13.2	36.2	23	—	0.6	—	—	4	0.3	0.3	16	13.8	5 430	6 890	6 890	1 610	4 680	
	CFES 10-1 BR	CFES 10-1 B	CFES 10-1 BUUR	CFES 10-1 BUU	60	26	12	10	M10×1.25	12	13.2	36.2	23	—	0.6	—	—	4	0.3	0.3	16	13.8	5 430	6 890	6 890	2 030	5 530	
12	CFES 12 BR	CFES 12 B	CFES 12 BUUR	CFES 12 BUU	95	30	14	12	M12×1.5	13	15.2	40.2	25	6	0.6	4	3	6	0.6	0.4	21	21.9	7 910	9 790	9 790	2 470	7 010	
	CFES 12-1 BR	CFES 12-1 B	CFES 12-1 BUUR	CFES 12-1 BUU	105	32	14	12	M12×1.5	13	15.2	40.2	25	6	0.6	4	3	6	0.6	0.4	21	21.9	7 910	9 790	9 790	2 710	7 480	
16	CFES 16 BR	CFES 16 B	CFES 16 BUUR	CFES 16 BUU	170	35	18	16	M16×1.5	17	19.6	52.1	32.5	8	0.8	4	3	6	0.6	0.5	26	58.5	12 000	18 300	18 300	3 060	11 200	
18	CFES 18 BR	CFES 18 B	CFES 18 BUUR	CFES 18 BUU	250	40	20	18	M18×1.5	19	21.6	58.1	36.5	8	0.8	6	3	8	1	0.6	29	86.2	14 800	25 200	25 200	3 660	14 500	

Note ⁽¹⁾ An oil hole (re-greasing fitting) is provided for the stud head.

⁽²⁾ An oil hole (grease nipple) is provided for the stud head and an oil hole is provided for the outside surface and the end of the stud.

⁽³⁾ Minimum allowable value of chamfer dimension r .

Remark Grease is pre-packed if the stud diameter d_1 of the shield type is 10 mm or less or if the seal structure is the sealed type. Other models are not provided with pre-packed grease. Perform proper lubrication for use.

Selectable product specifications

Type of material	No symbol	High carbon steel
	F	Stainless steel
Roller guide method	No symbol	With cage
	V	Full complement
Seal structure	No symbol	Shield type
	UU	Sealed type
Shape of outer ring outside surface	No symbol	Cylindrical outer ring
	R	Crowned outer ring

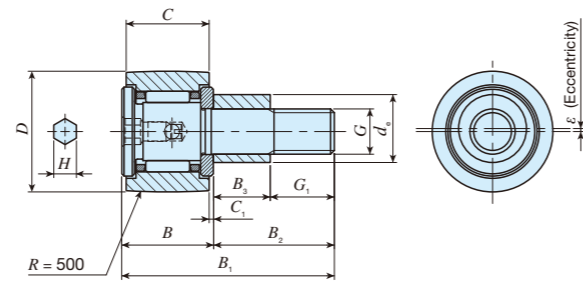
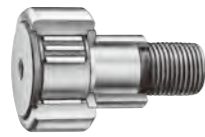

CFE...BR
Outside diameter of eccentric collar d_e 9 to 13 mm (1)

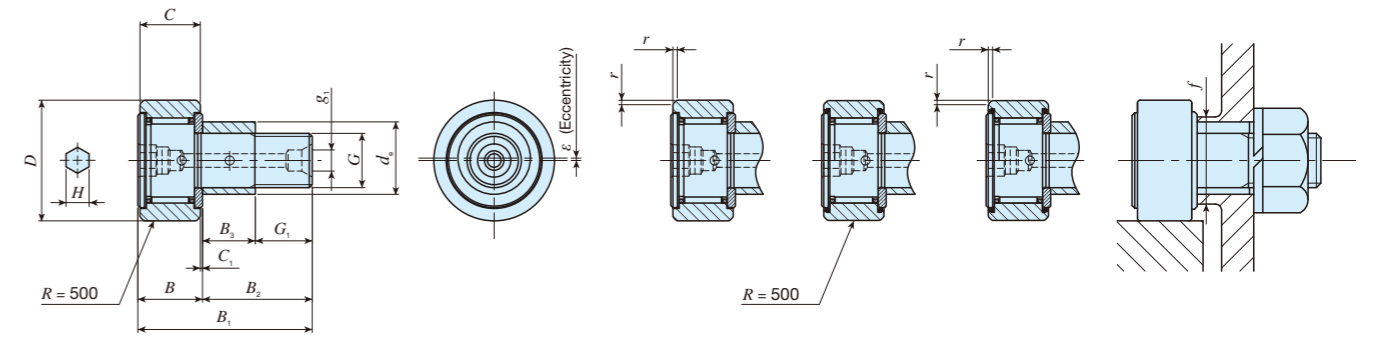

CFE...BR
Outside diameter of eccentric collar d_e 16 to 41 mm (2)

CFE...B CFE...BUUR CFE...BUU

Outside diameter of eccentric collar mm	Identification number				Mass (Ref.) g	Boundary dimensions mm															Mounting dimensions f Min. mm	Maximum tightening torque N·m	Basic dynamic load rating C N	Basic static load rating C_0 N	Maximum allowable static load N	Track capacity N	
	Shield type		Sealed type			D	C	d_e	G	B_3	B_{max}	B_{1max}	B_2	C_1	g_1	G_1	H	$r_{smin}^{(3)}$	Eccentricity ϵ	Crowned outer ring						Cylindrical outer ring	
	Crowned outer ring	Cylindrical outer ring	Crowned outer ring	Cylindrical outer ring																							
9	CFE 6 BR	CFE 6 B	CFE 6 BUUR	CFE 6 BUU	20.5	16	11	9	M 6×1	7.5	12.2	28.2	16	0.6	—	8.5	3	0.3	0.4	11	2.7	3 660	3 650	1 950	1 040	3 400	
11	CFE 8 BR	CFE 8 B	CFE 8 BUUR	CFE 8 BUU	32	19	11	11	M 8×1.25	9.5	12.2	32.2	20	0.6	—	10.5	4	0.3	0.4	13	6.5	4 250	4 740	4 620	1 330	4 040	
13	CFE 10 BR	CFE 10 B	CFE 10 BUUR	CFE 10 BUU	49.5	22	12	13	M10×1.25	10.5	13.2	36.2	23	0.6	—	12.5	4	0.3	0.4	16	13.8	5 430	6 890	6 890	1 610	4 680	
	CFE 10-1 BR	CFE 10-1 B	CFE 10-1 BUUR	CFE 10-1 BUU	65	26	12	13	M10×1.25	10.5	13.2	36.2	23	0.6	—	12.5	4	0.3	0.4	16	13.8	5 430	6 890	6 890	2 030	5 530	
16	CFE 12 BR	CFE 12 B	CFE 12 BUUR	CFE 12 BUU	105	30	14	16	M12×1.5	11.5	15.2	40.2	25	0.6	4	13.5	6	0.6	0.8	21	21.9	7 910	9 790	9 790	2 470	7 010	
	CFE 12-1 BR	CFE 12-1 B	CFE 12-1 BUUR	CFE 12-1 BUU	115	32	14	16	M12×1.5	11.5	15.2	40.2	25	0.6	4	13.5	6	0.6	0.8	21	21.9	7 910	9 790	9 790	2 710	7 480	
22	CFE 16 BR	CFE 16 B	CFE 16 BUUR	CFE 16 BUU	190	35	18	22	M16×1.5	15.5	19.6	52.1	32.5	0.8	4	17	6	0.6	0.8	26	58.5	12 000	18 300	18 300	3 060	11 200	
24	CFE 18 BR	CFE 18 B	CFE 18 BUUR	CFE 18 BUU	280	40	20	24	M18×1.5	17.5	21.6	58.1	36.5	0.8	6	19	8	1	0.8	29	86.2	14 800	25 200	25 200	3 660	14 500	
27	CFE 20 BR	CFE 20 B	CFE 20 BUUR	CFE 20 BUU	500	52	24	27	M20×1.5	19.5	25.6	66.1	40.5	0.8	6	21	8	1	0.8	34	119	20 700	34 600	34 600	5 190	23 200	
	CFE 20-1 BR	CFE 20-1 B	CFE 20-1 BUUR	CFE 20-1 BUU	425	47	24	27	M20×1.5	19.5	25.6	66.1	40.5	0.8	6	21	8	1	0.8	34	119	20 700	34 600	34 600	4 530	21 000	
33	CFE 24 BR	CFE 24 B	CFE 24 BUUR	CFE 24 BUU	895	62	29	33	M24×1.5	25.5	30.6	80.1	49.5	0.8	6	24	12	1	0.8	40	215	30 500	52 600	52 000	6 580	34 300	
	CFE 24-1 BR	CFE 24-1 B	CFE 24-1 BUUR	CFE 24-1 BUU	1 220	72	29	33	M24×1.5	25.5	30.6	80.1	49.5	0.8	6	24	12	1	0.8	40	215	30 500	52 600	52 000	8 020	39 800	
41	CFE 30 BR	CFE 30 B	CFE 30 BUUR	CFE 30 BUU	2 030	80	35	41	M30×1.5	32.5	37	100	63	1	6	30.5	17	1	1.5	49	438	45 400	85 100	85 100	9 220	52 700	
	CFE 30-1 BR	CFE 30-1 B	CFE 30-1 BUUR	CFE 30-1 BUU	2 190	85	35	41	M30×1.5	32.5	37	100	63	1	6	30.5	17	1	1.5	49	438	45 400	85 100	85 100	9 990	56 000	
	CFE 30-2 BR	CFE 30-2 B	CFE 30-2 BUUR	CFE 30-2 BUU	2 380	90	35	41	M30×1.5	32.5	37	100	63	1	6	30.5	17	1	1.5	49	438	45 400	85 100	85 100	10 800	59 300	

Note (1) An oil hole (re-greasing fitting) is provided for the stud head.

(2) An oil hole (grease nipple) is provided for the stud head and an oil hole is provided for the outside surface and the end of the stud.

(3) Minimum allowable value of chamfer dimension r .

Remark Grease is pre-packed if the stud thread diameter G of the shield type is 10 mm or less or if the seal structure is the sealed type. Other models are not provided with pre-packed grease. Perform proper lubrication for use.

Selectable product specifications

Type of material	No symbol	High carbon steel
	F	Stainless steel
Roller guide method	No symbol	With cage
	V	Full complement
Seal structure	No symbol	Shield type
	UU	Sealed type
Shape of outer ring outside surface	No symbol	Cylindrical outer ring
	R	Crowned outer ring

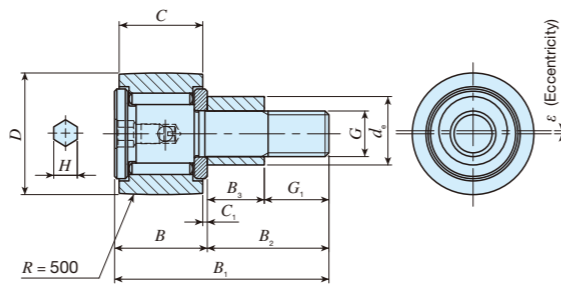
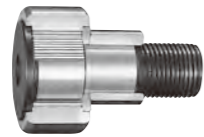

CFE...VBR
Outside diameter of eccentric collar d_e 9 to 13 mm (1)

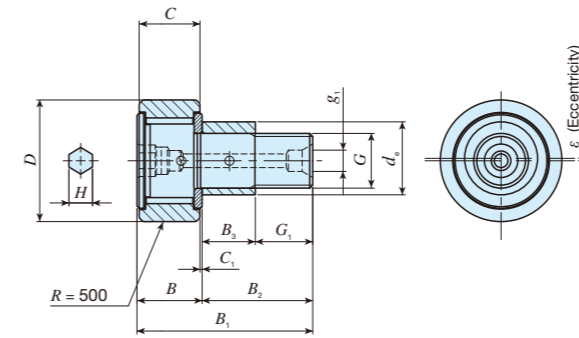

CFE...VBR
Outside diameter of eccentric collar d_e 16 to 41 mm (2)

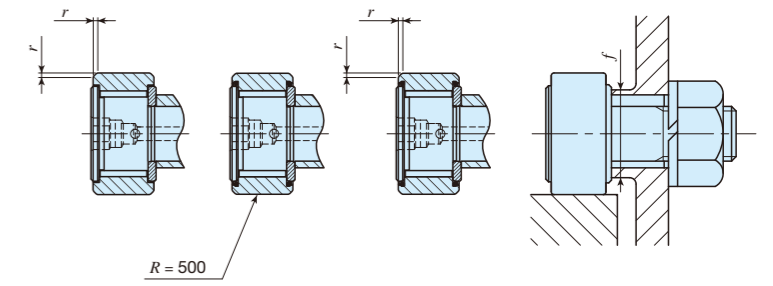

CFE...VB CFE...VBUUR CFE...VBUU

Outside diameter of eccentric collar mm	Identification number				Mass (Ref.) g	Boundary dimensions mm															Mounting dimensions f Min. mm	Maximum tightening torque N·m	Basic dynamic load rating C N	Basic static load rating C ₀ N	Maximum allowable static load N	Track capacity N	
	Shield type		Sealed type			D	C	d _e	G	B _s	Eccentricity					ε	Crowned outer ring	Cylindrical outer ring									
	Crowned outer ring	Cylindrical outer ring	Crowned outer ring	Cylindrical outer ring		B _{max}	B _{1max}	B ₂	C ₁	g ₁	G ₁	H	r _{s min} ⁽³⁾	ε													
9	CFE 6 VBR	CFE 6 VB	CFE 6 VBUUR	CFE 6 VBUU	21	16	11	9	M 6×1	7.5		12.2	28.2	16	0.6	—	8.5	3	0.3	0.4	11	2.7	6 980	8 500	1 950	1 040	3 400
11	CFE 8 VBR	CFE 8 VB	CFE 8 VBUUR	CFE 8 VBUU	32.5	19	11	11	M 8×1.25	9.5		12.2	32.2	20	0.6	—	10.5	4	0.3	0.4	13	6.5	8 170	11 200	4 620	1 330	4 040
13	CFE 10 VBR	CFE 10 VB	CFE 10 VBUUR	CFE 10 VBUU	50.5	22	12	13	M10×1.25	10.5		13.2	36.2	23	0.6	—	12.5	4	0.3	0.4	16	13.8	9 570	14 500	8 650	1 610	4 680
	CFE 10-1 VBR	CFE 10-1 VB	CFE 10-1 VBUUR	CFE 10-1 VBUU	66	26	12	13	M10×1.25	10.5		13.2	36.2	23	0.6	—	12.5	4	0.3	0.4	16	13.8	9 570	14 500	8 650	2 030	5 530
16	CFE 12 VBR	CFE 12 VB	CFE 12 VBUUR	CFE 12 VBUU	107	30	14	16	M12×1.5	11.5		15.2	40.2	25	0.6	4	13.5	6	0.6	0.8	21	21.9	13 500	19 700	13 200	2 470	7 010
	CFE 12-1 VBR	CFE 12-1 VB	CFE 12-1 VBUUR	CFE 12-1 VBUU	117	32	14	16	M12×1.5	11.5		15.2	40.2	25	0.6	4	13.5	6	0.6	0.8	21	21.9	13 500	19 700	13 200	2 710	7 480
22	CFE 16 VBR	CFE 16 VB	CFE 16 VBUUR	CFE 16 VBUU	193	35	18	22	M16×1.5	15.5		19.6	52.1	32.5	0.8	4	17	6	0.6	0.8	26	58.5	20 700	37 600	23 200	3 060	11 200
24	CFE 18 VBR	CFE 18 VB	CFE 18 VBUUR	CFE 18 VBUU	285	40	20	24	M18×1.5	17.5		21.6	58.1	36.5	0.8	6	19	8	1	0.8	29	86.2	25 300	51 300	31 100	3 660	14 500
27	CFE 20 VBR	CFE 20 VB	CFE 20 VBUUR	CFE 20 VBUU	505	52	24	27	M20×1.5	19.5		25.6	66.1	40.5	0.8	6	21	8	1	0.8	34	119	33 200	64 500	37 500	5 190	23 200
	CFE 20-1 VBR	CFE 20-1 VB	CFE 20-1 VBUUR	CFE 20-1 VBUU	430	47	24	27	M20×1.5	19.5		25.6	66.1	40.5	0.8	6	21	8	1	0.8	34	119	33 200	64 500	37 500	4 530	21 000
33	CFE 24 VBR	CFE 24 VB	CFE 24 VBUUR	CFE 24 VBUU	900	62	29	33	M24×1.5	25.5		30.6	80.1	49.5	0.8	6	24	12	1	0.8	40	215	46 600	92 000	52 000	6 580	34 300
	CFE 24-1 VBR	CFE 24-1 VB	CFE 24-1 VBUUR	CFE 24-1 VBUU	1 220	72	29	33	M24×1.5	25.5		30.6	80.1	49.5	0.8	6	24	12	1	0.8	40	215	46 600	92 000	52 000	8 020	39 800
41	CFE 30 VBR	CFE 30 VB	CFE 30 VBUUR	CFE 30 VBUU	2 030	80	35	41	M30×1.5	32.5		37	100	63	1	6	30.5	17	1	1.5	49	438	67 700	144 000	85 900	9 220	52 700
	CFE 30-1 VBR	CFE 30-1 VB	CFE 30-1 VBUUR	CFE 30-1 VBUU	2 190	85	35	41	M30×1.5	32.5		37	100	63	1	6	30.5	17	1	1.5	49	438	67 700	144 000	85 900	9 990	56 000
	CFE 30-2 VBR	CFE 30-2 VB	CFE 30-2 VBUUR	CFE 30-2 VBUU	2 380	90	35	41	M30×1.5	32.5		37	100	63	1	6	30.5	17	1	1.5	49	438	67 700	144 000	85 900	10 800	59 300

Note (1) An oil hole (re-greasing fitting) is provided for the stud head.
 (2) An oil hole (grease nipple) is provided for the stud head and an oil hole is provided for the outside surface and the end of the stud.
 (3) Minimum allowable value of chamfer dimension r.
 Remark Provided with pre-packed grease.

Cam Followers

Selectable product specifications

Type of material	No symbol	High carbon steel
	F	Stainless steel
Roller guide method	No symbol	With cage
	V	Full complement
Seal structure	No symbol	Shield type
	No symbol	Sealed type
Shape of outer ring outside surface	FU1	Cylindrical outer ring
	RU1	Crowned outer ring

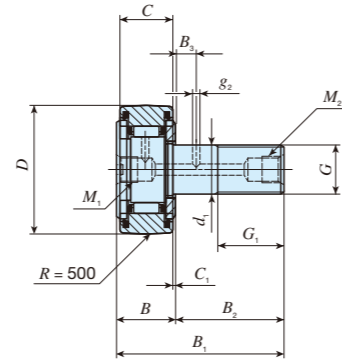

CF-RU1

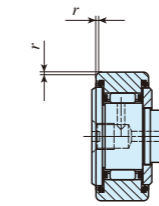

CF-FU1

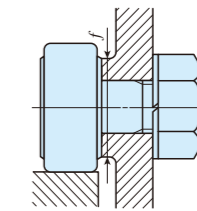

Stud diameter mm	Identification number		Mass (Ref.) g	Boundary dimensions mm																Mounting dimensions f Min. mm	Maximum tightening torque N·m	Basic dynamic load rating C N	Basic static load rating C ₀ N	Maximum allowable static load N	Track capacity N	
	Crowned outer ring	Cylindrical outer ring		D	C	d ₁	G	G ₁	B max	B ₁ max	B ₂	B ₃	C ₁	g ₂	M ₁	M ₂	r _{s min} ⁽¹⁾	Crown outer ring	Cylindrical outer ring							
																									Crown outer ring	Cylindrical outer ring
6	CF-RU1- 6	CF-FU1- 6	18.5	16	11	6	M 6×1	8	12.2	28.2	16	—	0.6	—	M6×0.75	—	0.3	11	2.7	3 660	3 650	1 950	1 040	3 400		
8	CF-RU1- 8	CF-FU1- 8	28.5	19	11	8	M 8×1.25	10	12.2	32.2	20	—	0.6	—			0.3	13	6.5	4 250	4 740	4 620	1 330	4 040		
10	CF-RU1-10	CF-FU1-10	45	22	12	10	M10×1.25	12	13.2	36.2	23	—	0.6	—	M6×0.75	—	0.3	16	13.8	5 430	6 890	6 890	1 610	4 680		
	CF-RU1-10-1	CF-FU1-10-1	60	26	12	10	M10×1.25	12	13.2	36.2	23	—	0.6	—			0.3	16	13.8	5 430	6 890	6 890	2 030	5 530		
12	CF-RU1-12	CF-FU1-12	95	30	14	12	M12×1.5	13	15.2	40.2	25	—	0.6	—	M6×0.75	—	0.6	21	23.9	7 910	9 790	9 790	2 470	7 010		
	CF-RU1-12-1	CF-FU1-12-1	105	32	14	12	M12×1.5	13	15.2	40.2	25	—	0.6	—			0.6	21	23.9	7 910	9 790	9 790	2 710	7 480		
16	CF-RU1-16	CF-FU1-16	170	35	18	16	M16×1.5	17	19.6	52.1	32.5	8	0.8	3	PT 1/8	PT 1/8	0.6	26	58.5	12 000	18 300	18 300	3 060	11 200		
18	CF-RU1-18	CF-FU1-18	250	40	20	18	M18×1.5	19	21.6	58.1	36.5	8	0.8	3			1	29	86.2	14 800	25 200	25 200	3 660	14 500		
20	CF-RU1-20	CF-FU1-20	460	52	24	20	M20×1.5	21	25.6	66.1	40.5	9	0.8	4	PT 1/8	PT 1/8	1	34	119.0	20 700	34 600	34 600	5 190	23 200		
	CF-RU1-20-1	CF-FU1-20-1	385	47	24	20	M20×1.5	21	25.6	66.1	40.5	9	0.8	4			1	34	119	20 700	34 600	34 600	4 530	21 000		
24	CF-RU1-24	CF-FU1-24	815	62	29	24	M24×1.5	25	30.6	80.1	49.5	11	0.8	4	PT 1/8	PT 1/8	1	40	215	30 500	52 600	52 000	6 580	34 300		
	CF-RU1-24-1	CF-FU1-24-1	1 140	72	29	24	M24×1.5	25	30.6	80.1	49.5	11	0.8	4			1	40	215	30 500	52 600	52 000	8 020	39 800		
30	CF-RU1-30	CF-FU1-30	1 870	80	35	30	M30×1.5	32	37	100	63	15	1	4	PT 1/8	PT 1/8	1	49	438	45 400	85 100	85 100	9 220	52 700		
	CF-RU1-30-1	CF-FU1-30-1	2 030	85	35	30	M30×1.5	32	37	100	63	15	1	4			1	49	438	45 400	85 100	85 100	9 990	56 000		
	CF-RU1-30-2	CF-FU1-30-2	2 220	90	35	30	M30×1.5	32	37	100	63	15	1	4			1	49	438	45 400	85 100	85 100	10 800	59 300		

Note (1) Minimum allowable value of chamfer dimension *r*.
 Remarks 1. A tapped hole for piping is provided only for the stud head if the stud diameter *d*₁ is 12 mm or less. As for the others, a tapped hole for piping is provided for the stud head and the end.
 2. Provided with pre-packed grease.

Selectable product specifications

Type of material	No symbol	High carbon steel
	F	Stainless steel
Roller guide method	No symbol	With cage
	V	Full complement
Seal structure	No symbol	Shield type
	No symbol	Sealed type
Shape of outer ring outside surface	No symbol	Cylindrical outer ring
	R	Crowned outer ring

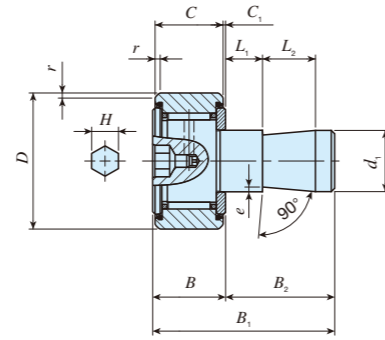

Stud dia. d_1 6 to 10 mm (1)

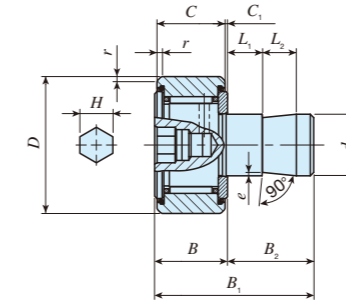

Stud dia. d_1 12 to 20 mm (2)

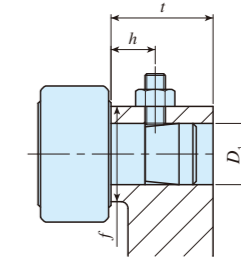

Stud diameter mm	Identification number With cage	Mass (Ref.) g	Boundary dimensions mm													Mounting dimensions mm					Basic dynamic load rating C N	Basic static load rating C_0 N	Maximum allowable static load N	Track capacity N	
			D	C	d_1	B_{max}	B_{1max}	B_2	C_1	L_1	L_2	H	e	$r_{smin}^{(3)}$	D_2	Tolerance	t Min.	f Min.	h (Ref.)						
6	CF-SFU- 6 B	19.5	16	11	6	12.2	32	19.8	0.6	5			10	3	0.3	0.3	6	+0.012 0	20	11	10	3 660	3 650	1 950	3 400
8	CF-SFU- 8 B	29	19	11	8	12.2	32	19.8	0.6	5			10	4	0.5	0.3	8	+0.015 0	20	13	10	4 250	4 740	4 620	4 040
10	CF-SFU- 10 B CF-SFU- 10-1 B	44 59	22 26	12 12	10 10	13.2 13.2	33 33	19.8 19.8	0.6 0.6	5 5			10 10	4 4	0.5 0.5	0.3 0.3	10 10		20	16	10	5 430 5 430	6 890 6 890	6 890 6 890	4 680 5 530
12	CF-SFU- 12 B CF-SFU- 12-1 B	94 104	30 32	14 14	12 12	15.2 15.2	35 35	19.8 19.8	0.6 0.6	5 5			10 10	6 6	1 1	0.6 0.6	12 12	+0.018 0	20	21	10	7 910 7 910	9 790 9 790	9 790 9 790	7 010 7 480
16	CF-SFU- 16 B	164	35	18	16	19.6	44.5	24.9	0.8	10			10	6	1	0.6	16		25	26	15	12 000	18 300	18 300	11 200
18	CF-SFU- 18 B	235	40	20	18	21.6	46.5	24.9	0.8	10			10	8	1	1	18	25	29	15	14 800	25 200	25 200	14 500	
20	CF-SFU- 20 B CF-SFU- 20-1 B	435 360	52 47	24 24	20 20	25.6 25.6	50.5 50.5	24.9 24.9	0.8 0.8	10 10			10 10	8 8	1 1	1 1	20 20	+0.021 0	25	34	15	20 700 20 700	34 600 34 600	34 600 34 600	23 200 21 000

Note (1) An oil hole (re-greasing fitting) is provided for the stud head.

(2) An oil hole (grease nipple) is provided for the stud head.

(3) Minimum allowable value of chamfer dimension r .

Remark Provided with pre-packed grease.

Selectable product specifications

Type of material	No symbol	High carbon steel
	F	Stainless steel
Roller guide method	No symbol	With cage
	No symbol	Full complement
Seal structure	No symbol	Shield type
	UU	Sealed type
Shape of outer ring outside surface	No symbol	Cylindrical outer ring
	R	Crowned outer ring

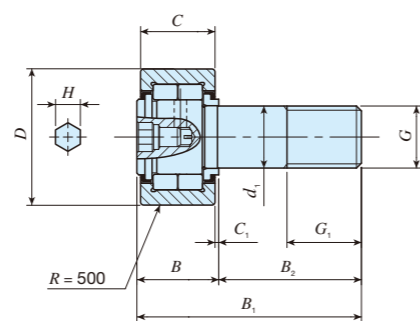
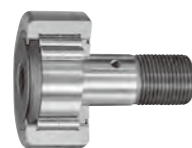

Stud dia. d_1 10 mm (1)

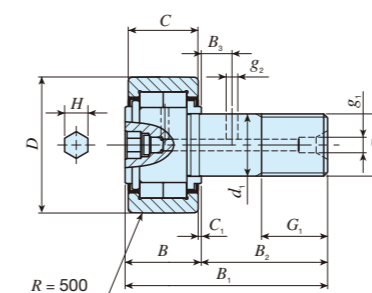

Stud dia. d_1 12 to 30 mm (2)

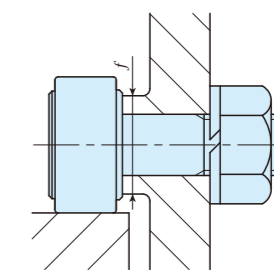

Stud diameter mm	Identification number	Mass (Ref.) g	Boundary dimensions mm														Mounting dimensions f Min. mm	Maximum tightening torque N·m	Basic dynamic load rating C N	Basic static load rating C_0 N	Maximum allowable static load N	Track capacity N
			D	C	d_1	G	G_1	B_{max}	B_{max}	B_2	B_3	C_1	g_1	g_2	H							
10	NUCF 10 BR	44	22	12	10	M10×1.25	12	13.2	36.2	23	—	0.6	—	—	4	12	13.8	10 400	11 500	5 300	1 610	
	NUCF 10-1 BR	58	26	12	10	M10×1.25	12	13.2	36.2	23	—	0.6	—	—	4	12	13.8	10 400	11 500	9 210	2 030	
12	NUCF 12 BR	86	30	14	12	M12×1.5	13	15.2	40.2	25	6	0.6	4	3	6	17	21.9	14 000	13 400	5 650	2 470	
	NUCF 12-1 BR	97	32	14	12	M12×1.5	13	15.2	40.2	25	6	0.6	4	3	6	17	21.9	14 000	13 400	9 040	2 710	
16	NUCF 16 BR	167	35	18	16	M16×1.5	17	19.6	52.1	32.5	8	0.8	4	3	6	20	58.5	23 400	27 300	11 800	3 060	
18	NUCF 18 BR	244	40	20	18	M18×1.5	19	21.6	58.1	36.5	8	0.8	6	3	8	22	86.2	25 200	30 900	20 300	3 660	
20	NUCF 20 BR	457	52	24	20	M20×1.5	21	25.6	66.1	40.5	9	0.8	6	4	8	31	119	43 100	58 100	30 000	5 190	
	NUCF 20-1 BR	384	47	24	20	M20×1.5	21	25.6	66.1	40.5	9	0.8	6	4	8	27	119	38 900	49 000	27 200	4 530	
24	NUCF 24 BR	789	62	29	24	M24×1.5	25	30.6	80.1	49.5	11	0.8	6	4	12	38	215	58 200	75 300	35 200	6 580	
	NUCF 24-1 BR	1 020	72	29	24	M24×1.5	25	30.6	80.1	49.5	11	0.8	6	4	12	44	215	63 900	88 800	57 000	8 020	
30	NUCF 30 BR	1 600	80	35	30	M30×1.5	32	37	100	63	15	1	6	4	17	45	438	90 300	121 000	98 300	9 220	
	NUCF 30-2 BR	1 970	90	35	30	M30×1.5	32	37	100	63	15	1	6	4	17	45	438	90 300	121 000	98 300	10 800	

Note (1) An oil hole (re-greasing fitting) is provided for the stud head.

(2) An oil hole (grease nipple) is provided for the stud head and an oil hole is provided for the outside surface and the end of the stud.

Remark Provided with pre-packed grease.

Selectable product specifications

Type of material	No symbol	High carbon steel
	F	Stainless steel
Roller guide method	No symbol	With cage
	V	Full complement
Seal structure	No symbol	Shield type
	UU	Sealed type
Shape of outer ring outside surface	No symbol	Cylindrical outer ring
	R	Crowned outer ring

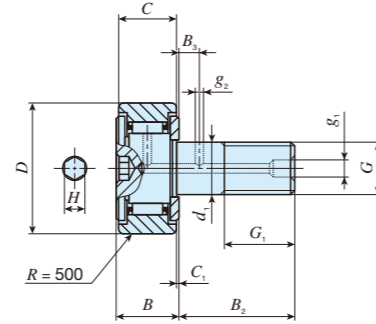
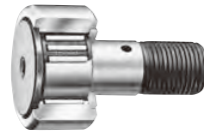

CR···BR

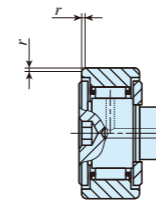

CR···B

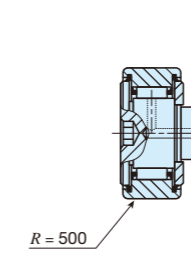

CR···BUUR

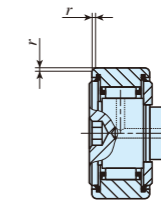

CR···BUU

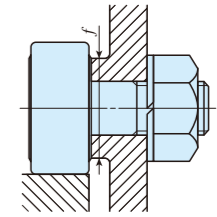

Stud diameter mm (inch)	Identification number				Mass (Ref.) g	Boundary dimensions mm (inch)													Mounting dimensions f Min. mm (inch)	Maximum tightening torque N·m	Basic dynamic load rating C N	Basic static load rating C ₀ N	Track capacity N		
	Shield type		Sealed type			D	C	d ₁	G UNF	G ₁	B max	B ₂	B ₃	C ₁	g ₁	g ₂	H	r					Crowned outer ring	Cylindrical outer ring	
	Crowned outer ring	Cylindrical outer ring	Crowned outer ring	Cylindrical outer ring																					
4.826	CR 8 BR	CR 8 B	CR 8 BUUR	CR 8 BUU	9	12.700 (1/2)	8.731 (11/32)	4.826	No.10-32	6.350 (1/4)	10.2 (0.40)		12.700 (1/2)	— (—)	0.794 (1/32)	— (—)	— (—)	3.175 (1/8)	0.397 (1/64)	8.334 (3/16)	1.4	2 520	2 140	770	2 140
	CR 8-1 BR	CR 8-1 B	CR 8-1 BUUR	CR 8-1 BUU	10	12.700 (1/2)	8.525 (3/8)	4.826	No.10-32	6.350 (1/4)	10.9 (0.43)		15.875 (3/8)	— (—)	0.794 (1/32)	— (—)	— (—)	3.175 (1/8)	0.397 (1/64)	8.334 (3/16)	1.4	2 520	2 140	770	2 360
6.350 (1/4)	CR 10 BR	CR 10 B	CR 10 BUUR	CR 10 BUU	19	15.875 (3/8)	10.319 (13/32)	6.350 (1/4)	1/4 - 28	7.938 (5/16)	11.8 (0.46)		15.875 (3/8)	— (—)	0.794 (1/32)	— (—)	— (—)	3.175 (1/8)	0.397 (1/64)	11.509 (3/16)	3.4	3 650	3 670	1 030	3 210
	CR 10-1 BR	CR 10-1 B	CR 10-1 BUUR	CR 10-1 BUU	21	15.875 (3/8)	11.112 (7/16)	6.350 (1/4)	1/4 - 28	7.938 (5/16)	12.5 (0.49)		19.050 (3/4)	— (—)	0.794 (1/32)	— (—)	— (—)	3.175 (1/8)	0.397 (1/64)	11.509 (3/16)	3.4	3 650	3 670	1 030	3 480
9.525 (3/8)	CR 12 BR	CR 12 B	CR 12 BUUR	CR 12 BUU	35	19.050 (3/4)	12.700 (1/2)	9.525 (3/8)	3/8 - 24	9.525 (3/8)	14.2 (0.56)		22.225 (7/8)	6.350 (1/4)	0.794 (1/32)	4.762 (3/16)	2.381 (3/32)	4.762 (3/16)	0.794 (1/32)	13.494 (1/2)	10.8	4 420	5 110	1 340	4 500
	CR 14 BR	CR 14 B	CR 14 BUUR	CR 14 BUU	46	22.225 (7/8)	12.700 (1/2)	9.525 (3/8)	3/8 - 24	9.525 (3/8)	14.2 (0.56)		22.225 (7/8)	6.350 (1/4)	0.794 (1/32)	4.762 (3/16)	2.381 (3/32)	4.762 (3/16)	0.794 (1/32)	15.081 (11/16)	10.8	4 790	5 810	1 630	5 250
11.112 (7/16)	CR 16 BR	CR 16 B	CR 16 BUUR	CR 16 BUU	73	25.400 (1)	15.875 (5/8)	11.112 (7/16)	7/16 - 20	12.700 (1/2)	17.3 (0.68)		25.400 (1)	6.350 (1/4)	0.794 (1/32)	4.762 (3/16)	3.175 (1/8)	6.350 (1/4)	1.191 (3/64)	17.859 (5/16)	17.4	8 810	10 800	1 970	7 280
	CR 18 BR	CR 18 B	CR 18 BUUR	CR 18 BUU	88	28.575 (1 1/8)	15.875 (5/8)	11.112 (7/16)	7/16 - 20	12.700 (1/2)	17.3 (0.68)		25.400 (1)	6.350 (1/4)	0.794 (1/32)	4.762 (3/16)	3.175 (1/8)	6.350 (1/4)	1.588 (1/16)	19.050 (3/4)	17.4	9 180	11 600	2 300	7 710
12.700 (1/2)	CR 20 BR	CR 20 B	CR 20 BUUR	CR 20 BUU	132	31.750 (1 1/4)	19.050 (3/4)	12.700 (1/2)	1/2 - 20	15.875 (5/8)	20.4 (0.80)		31.750 (1 1/4)	7.938 (5/16)	0.794 (1/32)	4.762 (3/16)	3.175 (1/8)	6.350 (1/4)	1.588 (1/16)	21.828 (5/16)	27.7	14 200	16 000	2 680	10 700
	CR 22 BR	CR 22 B	CR 22 BUUR	CR 22 BUU	157	34.925 (1 3/8)	19.050 (3/4)	12.700 (1/2)	1/2 - 20	15.875 (5/8)	20.4 (0.80)		31.750 (1 1/4)	7.938 (5/16)	0.794 (1/32)	4.762 (3/16)	3.175 (1/8)	6.350 (1/4)	1.588 (1/16)	21.828 (5/16)	27.7	14 200	16 000	3 050	11 800
15.875 (5/8)	CR 24 BR	CR 24 B	CR 24 BUUR	CR 24 BUU	225	38.100 (1 1/2)	22.225 (7/8)	15.875 (5/8)	5/8 - 18	19.050 (3/4)	23.6 (0.93)		38.100 (1 1/2)	9.525 (3/8)	0.794 (1/32)	4.762 (3/16)	3.969 (5/32)	7.938 (5/16)	1.588 (1/16)	26.196 (1 3/16)	55.7	18 600	24 300	3 410	15 400
	CR 26 BR	CR 26 B	CR 26 BUUR	CR 26 BUU	260	41.275 (1 5/8)	22.225 (7/8)	15.875 (5/8)	5/8 - 18	19.050 (3/4)	23.6 (0.93)		38.100 (1 1/2)	9.525 (3/8)	0.794 (1/32)	4.762 (3/16)	3.969 (5/32)	7.938 (5/16)	1.588 (1/16)	26.196 (1 3/16)	55.7	18 900	24 300	3 820	16 700
19.050 (3/4)	CR 28 BR	CR 28 B	CR 28 BUUR	CR 28 BUU	365	44.450 (1 3/4)	25.400 (1)	19.050 (3/4)	3/4 - 16	22.225 (7/8)	26.8 (1.06)		44.450 (1 3/4)	11.112 (7/16)	0.794 (1/32)	4.762 (3/16)	3.969 (5/32)	7.938 (5/16)	1.588 (1/16)	32.543 (1 3/32)	100	25 100	38 200	4 210	21 000
	CR 30 BR	CR 30 B	CR 30 BUUR	CR 30 BUU	410	47.625 (1 7/8)	25.400 (1)	19.050 (3/4)	3/4 - 16	22.225 (7/8)	26.8 (1.06)		44.450 (1 3/4)	11.112 (7/16)	0.794 (1/32)	4.762 (3/16)	3.969 (5/32)	7.938 (5/16)	1.588 (1/16)	32.543 (1 3/32)	100	25 100	38 200	4 610	22 500
22.225 (7/8)	CR 32 BR	CR 32 B	CR 32 BUUR	CR 32 BUU	615	50.800 (2)	31.750 (1 1/4)	22.225 (7/8)	7/8 - 14	25.400 (1)	33.5 (1.32)		50.800 (2)	12.700 (1/2)	0.794 (1/32)	4.762 (3/16)	4.762 (3/16)	11.112 (7/16)	1.588 (1/16)	37.306 (1 15/32)	162	32 500	63 900	5 050	30 900
	CR 36 BR	CR 36 B	CR 36 BUUR	CR 36 BUU	750	57.150 (2 1/4)	31.750 (1 1/4)	22.225 (7/8)	7/8 - 14	25.400 (1)	33.5 (1.32)		50.800 (2)	12.700 (1/2)	0.794 (1/32)	4.762 (3/16)	4.762 (3/16)	11.112 (7/16)	1.588 (1/16)	37.306 (1 15/32)	162	32 500	63 900	5 900	34 700

Remarks 1. No oil hole is provided if the stud diameter d_1 is 6.35 mm or less. As for the others, an oil hole is provided for the head, the outside surface, and the end of the stud.
 2. Provided with pre-packed grease.
 3. Contact **IKO** for the information on the maximum allowable static load.

Selectable product specifications

Type of material	No symbol	High carbon steel
	F	Stainless steel
Roller guide method	No symbol	With cage
	V	Full complement
Seal structure	No symbol	Shield type
	UU	Sealed type
Shape of outer ring outside surface	No symbol	Cylindrical outer ring
	R	Crowned outer ring

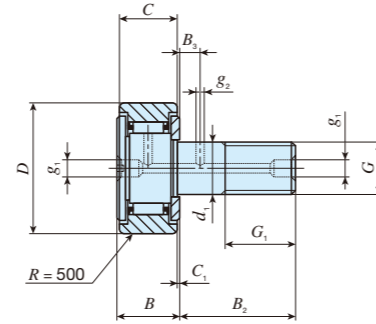

CR...R

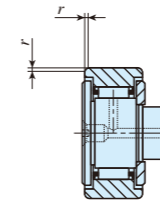

CR

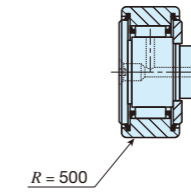

CR...UUR

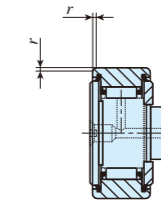

CR...UU

Stud diameter mm (inch)	Identification number				Mass (Ref.) g	Boundary dimensions mm (inch)											Mounting dimensions f Min. mm (inch)	Maximum tightening torque N·m	Basic dynamic load rating C N	Basic static load rating C ₀ N	Track capacity			
	Shield type		Sealed type			D	C	d ₁	G UNF	G ₁	B max	B ₂	B ₃	C ₁	g ₁	g ₂					r	Crowned outer ring	Cylindrical outer ring	
	Crowned outer ring	Cylindrical outer ring	Crowned outer ring	Cylindrical outer ring																				
4.826 (1/8)	CR 8 R	CR 8	CR 8 UUR	CR 8 UU	9	12.700 (1/2)	8.731 (1/2)	4.826	No.10-32	6.350 (1/4)	10.2 (0.40)		12.700 (1/2)	— (—)	0.794 (1/32)	3.175 (1/8)	— (—)	0.397 (1/64)	8.334 (2/64)	1.4	2 520	2 140	770	2 140
	CR 8-1 R	CR 8-1	CR 8-1 UUR	CR 8-1 UU	10	12.700 (1/2)	9.525 (3/8)	4.826	No.10-32	6.350 (1/4)	10.9 (0.43)		15.875 (5/8)	— (—)	0.794 (1/32)	3.175 (1/8)	— (—)	0.397 (1/64)	8.334 (2/64)	1.4	2 520	2 140	770	2 360
6.350 (1/4)	CR 10 R	CR 10	CR 10 UUR	CR 10 UU	19	15.875 (5/8)	10.319 (1/2)	6.350 (1/4)	1/4 - 28	7.938 (5/16)	11.8 (0.46)		15.875 (5/8)	— (—)	0.794 (1/32)	3.175 (1/8)	— (—)	0.397 (1/64)	11.509 (29/64)	3.4	3 650	3 670	1 030	3 210
	CR 10-1 R	CR 10-1	CR 10-1 UUR	CR 10-1 UU	21	15.875 (5/8)	11.112 (7/16)	6.350 (1/4)	1/4 - 28	7.938 (5/16)	12.5 (0.49)		19.050 (3/4)	— (—)	0.794 (1/32)	3.175 (1/8)	— (—)	0.397 (1/64)	11.509 (29/64)	3.4	3 650	3 670	1 030	3 480
9.525 (3/8)	CR 12 R	CR 12	CR 12 UUR	CR 12 UU	35	19.050 (3/4)	12.700 (1/2)	9.525 (3/8)	5/8 - 24	9.525 (3/8)	14.2 (0.56)		22.225 (7/8)	6.350 (1/4)	0.794 (1/32)	4.762 (3/16)	2.381 (3/32)	0.794 (1/32)	13.494 (1/2)	10.8	4 420	5 110	1 340	4 500
	CR 14 R	CR 14	CR 14 UUR	CR 14 UU	46	22.225 (7/8)	12.700 (1/2)	9.525 (3/8)	5/8 - 24	9.525 (3/8)	14.2 (0.56)		22.225 (7/8)	6.350 (1/4)	0.794 (1/32)	4.762 (3/16)	2.381 (3/32)	0.794 (1/32)	15.081 (19/32)	10.8	4 420	5 810	1 630	5 250
11.112 (7/16)	CR 16 R	CR 16	CR 16 UUR	CR 16 UU	73	25.400 (1)	15.875 (5/8)	11.112 (7/16)	7/16 - 20	12.700 (1/2)	17.3 (0.68)		25.400 (1)	6.350 (1/4)	0.794 (1/32)	4.762 (3/16)	3.175 (1/8)	1.191 (3/64)	17.859 (5/64)	17.4	8 810	10 800	1 970	7 280
	CR 18 R	CR 18	CR 18 UUR	CR 18 UU	88	28.575 (1 1/8)	15.875 (5/8)	11.112 (7/16)	7/16 - 20	12.700 (1/2)	17.3 (0.68)		25.400 (1)	6.350 (1/4)	0.794 (1/32)	4.762 (3/16)	3.175 (1/8)	1.588 (1/16)	19.050 (3/4)	17.4	9 180	11 600	2 300	7 710
12.700 (1/2)	CR 20 R	CR 20	CR 20 UUR	CR 20 UU	132	31.750 (1 1/4)	19.050 (3/4)	12.700 (1/2)	1/2 - 20	15.875 (5/8)	20.4 (0.80)		31.750 (1 1/4)	7.938 (5/16)	0.794 (1/32)	4.762 (3/16)	3.175 (1/8)	1.588 (1/16)	21.828 (55/64)	27.7	14 200	16 000	2 680	10 700
	CR 22 R	CR 22	CR 22 UUR	CR 22 UU	157	34.925 (1 3/8)	19.050 (3/4)	12.700 (1/2)	1/2 - 20	15.875 (5/8)	20.4 (0.80)		31.750 (1 1/4)	7.938 (5/16)	0.794 (1/32)	4.762 (3/16)	3.175 (1/8)	1.588 (1/16)	21.828 (55/64)	27.7	14 200	16 000	3 050	11 800
15.875 (5/8)	CR 24 R	CR 24	CR 24 UUR	CR 24 UU	225	38.100 (1 1/2)	22.225 (7/8)	15.875 (5/8)	5/8 - 18	19.050 (3/4)	23.6 (0.93)		38.100 (1 1/2)	9.525 (3/8)	0.794 (1/32)	4.762 (3/16)	3.969 (3/32)	1.588 (1/16)	26.196 (1 3/64)	55.7	18 600	24 300	3 410	15 400
	CR 26 R	CR 26	CR 26 UUR	CR 26 UU	260	41.275 (1 5/8)	22.225 (7/8)	15.875 (5/8)	5/8 - 18	19.050 (3/4)	23.6 (0.93)		38.100 (1 1/2)	9.525 (3/8)	0.794 (1/32)	4.762 (3/16)	3.969 (3/32)	1.588 (1/16)	26.196 (1 3/64)	55.7	18 900	24 300	3 820	16 700
19.050 (3/4)	CR 28 R	CR 28	CR 28 UUR	CR 28 UU	365	44.450 (1 3/4)	25.400 (1)	19.050 (3/4)	3/4 - 16	22.225 (7/8)	26.8 (1.06)		44.450 (1 3/4)	11.112 (7/16)	0.794 (1/32)	4.762 (3/16)	3.969 (3/32)	1.588 (1/16)	32.543 (1 5/32)	100	25 100	38 200	4 210	21 000
	CR 30 R	CR 30	CR 30 UUR	CR 30 UU	410	47.625 (1 7/8)	25.400 (1)	19.050 (3/4)	3/4 - 16	22.225 (7/8)	26.8 (1.06)		44.450 (1 3/4)	11.112 (7/16)	0.794 (1/32)	4.762 (3/16)	3.969 (3/32)	1.588 (1/16)	32.543 (1 5/32)	100	25 100	38 200	4 610	22 500
22.225 (7/8)	CR 32 R	CR 32	CR 32 UUR	CR 32 UU	615	50.800 (2)	31.750 (1 1/4)	22.225 (7/8)	7/8 - 14	25.400 (1)	33.5 (1.32)		50.800 (2)	12.700 (1/2)	0.794 (1/32)	4.762 (3/16)	4.762 (3/16)	1.588 (1/16)	37.306 (1 15/32)	162	32 500	63 900	5 050	30 900
	CR 36 R	CR 36	CR 36 UUR	CR 36 UU	750	57.150 (2 1/4)	31.750 (1 1/4)	22.225 (7/8)	7/8 - 14	25.400 (1)	33.5 (1.32)		50.800 (2)	12.700 (1/2)	0.794 (1/32)	4.762 (3/16)	4.762 (3/16)	1.588 (1/16)	37.306 (1 15/32)	162	32 500	63 900	5 900	34 700

Remarks 1. An oil hole is provided only for the stud head if the stud diameter d_1 is 6.35 mm or less. As for the others, an oil hole is provided for the head, the outside surface, and the end of the stud.
 2. Provided with pre-packed grease.
 3. Contact **IKO** for the information on the maximum allowable static load.

Selectable product specifications

Type of material	No symbol	High carbon steel
	F	Stainless steel
Roller guide method	No symbol	With cage
	V	Full complement
Seal structure	No symbol	Shield type
	UU	Sealed type
Shape of outer ring outside surface	No symbol	Cylindrical outer ring
	R	Crowned outer ring

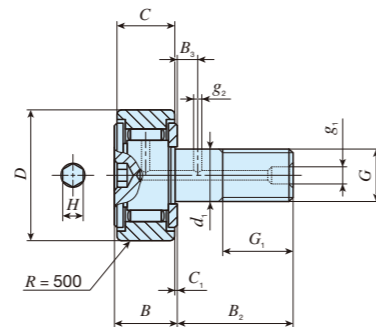

CR...VBR

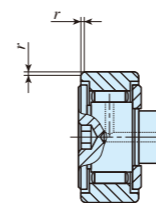

CR...VB

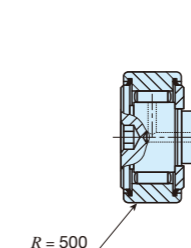

CR...VBUUR

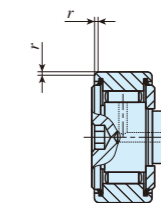

CR...VBUU

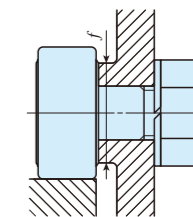

Stud diameter mm (inch)	Identification number				Mass (Ref.) g	Boundary dimensions mm (inch)													Mounting dimensions f Min. mm (inch)	Maximum tightening torque N·m	Basic dynamic load rating C N	Basic static load rating C ₀ N	Track capacity N	
	Shield type		Sealed type			D	C	d ₁	G UNF	G ₁	B max	B ₂	B ₃	C ₁	g ₁	g ₂	H	r					Crowned outer ring	Cylindrical outer ring
	Crowned outer ring	Cylindrical outer ring	Crowned outer ring	Cylindrical outer ring																				
4.826	CR 8 VBR	CR 8 VB	CR 8 VBUUR	CR 8 VBUU	9	12.700 (1/2)	8.731 (11/32)	4.826	No.10-32	6.350 (1/4)	10.2 (0.40)	12.700 (1/2)	— (—)	0.794 (1/32)	— (—)	— (—)	3.175 (1/8)	0.397 (1/64)	8.334 (25/64)	1.4	4 260	4 750	770	2 140
	CR 8-1 VBR	CR 8-1 VB	CR 8-1 VBUUR	CR 8-1 VBUU	10	12.700 (1/2)	8.525 (3/8)	4.826	No.10-32	6.350 (1/4)	10.9 (0.43)	15.875 (5/8)	— (—)	0.794 (1/32)	— (—)	— (—)	3.175 (1/8)	0.397 (1/64)	8.334 (25/64)	1.4	4 710	5 410	770	2 360
6.350 (1/4)	CR 10 VBR	CR 10 VB	CR 10 VBUUR	CR 10 VBUU	19	15.875 (5/8)	10.319 (13/32)	6.350 (1/4)	1/4 - 28	7.938 (5/16)	11.8 (0.46)	15.875 (5/8)	— (—)	0.794 (1/32)	— (—)	— (—)	3.175 (1/8)	0.397 (1/64)	11.509 (29/64)	3.4	5 830	7 660	1 030	3 210
	CR 10-1 VBR	CR 10-1 VB	CR 10-1 VBUUR	CR 10-1 VBUU	21	15.875 (5/8)	11.112 (7/16)	6.350 (1/4)	1/4 - 28	7.938 (5/16)	12.5 (0.49)	19.050 (3/4)	— (—)	0.794 (1/32)	— (—)	— (—)	3.175 (1/8)	0.397 (1/64)	11.509 (29/64)	3.4	6 340	8 530	1 030	3 480
9.525 (3/8)	CR 12 VBR	CR 12 VB	CR 12 VBUUR	CR 12 VBUU	36	19.050 (3/4)	12.700 (1/2)	9.525 (3/8)	3/8 - 24	9.525 (3/8)	14.2 (0.56)	22.225 (7/8)	6.350 (1/4)	0.794 (1/32)	4.762 (3/16)	2.381 (3/32)	4.762 (3/16)	0.794 (1/32)	13.494 (17/32)	10.8	8 710	12 300	1 340	4 500
	CR 14 VBR	CR 14 VB	CR 14 VBUUR	CR 14 VBUU	47	22.225 (7/8)	12.700 (1/2)	9.525 (3/8)	3/8 - 24	9.525 (3/8)	14.2 (0.56)	22.225 (7/8)	6.350 (1/4)	0.794 (1/32)	4.762 (3/16)	2.381 (3/32)	4.762 (3/16)	0.794 (1/32)	15.081 (19/32)	10.8	8 710	12 300	1 630	5 250
11.112 (7/16)	CR 16 VBR	CR 16 VB	CR 16 VBUUR	CR 16 VBUU	74	25.400 (1)	15.875 (5/8)	11.112 (7/16)	7/16 - 20	12.700 (1/2)	17.3 (0.68)	25.400 (1)	6.350 (1/4)	0.794 (1/32)	4.762 (3/16)	3.175 (1/8)	6.350 (1/4)	1.191 (3/64)	17.859 (5/64)	17.4	13 100	22 700	1 970	7 280
	CR 18 VBR	CR 18 VB	CR 18 VBUUR	CR 18 VBUU	85	28.575 (1 1/8)	15.875 (5/8)	11.112 (7/16)	7/16 - 20	12.700 (1/2)	17.3 (0.68)	25.400 (1)	6.350 (1/4)	0.794 (1/32)	4.762 (3/16)	3.175 (1/8)	6.350 (1/4)	1.588 (1/16)	19.050 (3/4)	17.4	13 100	22 700	2 300	7 710
12.700 (1/2)	CR 20 VBR	CR 20 VB	CR 20 VBUUR	CR 20 VBUU	137	31.750 (1 1/4)	19.050 (3/4)	12.700 (1/2)	1/2 - 20	15.875 (5/8)	20.4 (0.80)	31.750 (1 1/4)	7.938 (5/16)	0.794 (1/32)	4.762 (3/16)	3.175 (1/8)	6.350 (1/4)	1.588 (1/16)	21.828 (55/64)	27.7	23 600	31 700	2 680	10 700
	CR 22 VBR	CR 22 VB	CR 22 VBUUR	CR 22 VBUU	160	34.925 (1 3/8)	19.050 (3/4)	12.700 (1/2)	1/2 - 20	15.875 (5/8)	20.4 (0.80)	31.750 (1 1/4)	7.938 (5/16)	0.794 (1/32)	4.762 (3/16)	3.175 (1/8)	6.350 (1/4)	1.588 (1/16)	21.828 (55/64)	27.7	23 600	31 700	3 050	11 800
15.875 (5/8)	CR 24 VBR	CR 24 VB	CR 24 VBUUR	CR 24 VBUU	230	38.100 (1 1/2)	22.225 (7/8)	15.875 (5/8)	5/8 - 18	19.050 (3/4)	23.6 (0.93)	38.100 (1 1/2)	9.525 (3/8)	0.794 (1/32)	4.762 (3/16)	3.969 (5/32)	7.938 (5/16)	1.588 (1/16)	26.196 (1 3/64)	55.7	28 200	40 100	3 410	15 400
	CR 26 VBR	CR 26 VB	CR 26 VBUUR	CR 26 VBUU	265	41.275 (1 5/8)	22.225 (7/8)	15.875 (5/8)	5/8 - 18	19.050 (3/4)	23.6 (0.93)	38.100 (1 1/2)	9.525 (3/8)	0.794 (1/32)	4.762 (3/16)	3.969 (5/32)	7.938 (5/16)	1.588 (1/16)	26.196 (1 3/64)	55.7	28 200	40 100	3 820	16 700
19.050 (3/4)	CR 28 VBR	CR 28 VB	CR 28 VBUUR	CR 28 VBUU	372	44.450 (1 3/4)	25.400 (1)	19.050 (3/4)	3/4 - 16	22.225 (7/8)	26.8 (1.06)	44.450 (1 3/4)	11.112 (7/16)	0.794 (1/32)	4.762 (3/16)	3.969 (5/32)	7.938 (5/16)	1.588 (1/16)	32.543 (1 3/32)	100	35 300	55 600	4 210	21 000
	CR 30 VBR	CR 30 VB	CR 30 VBUUR	CR 30 VBUU	418	47.625 (1 7/8)	25.400 (1)	19.050 (3/4)	3/4 - 16	22.225 (7/8)	26.8 (1.06)	44.450 (1 3/4)	11.112 (7/16)	0.794 (1/32)	4.762 (3/16)	3.969 (5/32)	7.938 (5/16)	1.588 (1/16)	32.543 (1 3/32)	100	35 300	55 600	4 610	22 500
22.225 (7/8)	CR 32 VBR	CR 32 VB	CR 32 VBUUR	CR 32 VBUU	627	50.800 (2)	31.750 (1 1/4)	22.225 (7/8)	7/8 - 14	25.400 (1)	33.5 (1.32)	50.800 (2)	12.700 (1/2)	0.794 (1/32)	4.762 (3/16)	4.762 (3/16)	11.112 (7/16)	1.588 (1/16)	37.306 (1 15/32)	162	45 700	80 600	5 050	30 900
	CR 36 VBR	CR 36 VB	CR 36 VBUUR	CR 36 VBUU	759	57.150 (2 1/4)	31.750 (1 1/4)	22.225 (7/8)	7/8 - 14	25.400 (1)	33.5 (1.32)	50.800 (2)	12.700 (1/2)	0.794 (1/32)	4.762 (3/16)	4.762 (3/16)	11.112 (7/16)	1.588 (1/16)	37.306 (1 15/32)	162	45 700	80 600	5 900	34 700

Remarks 1. No oil hole is provided if the stud diameter d_1 is 6.35 mm or less. As for the others, an oil hole is provided for the head, the outside surface, and the end of the stud.
 2. Provided with pre-packed grease.
 3. Contact **IKO** for the information on the maximum allowable static load.

Selectable product specifications

Type of material	No symbol	High carbon steel
	F	Stainless steel
Roller guide method	No symbol	With cage
	V	Full complement
Seal structure	No symbol	Shield type
	UU	Sealed type
Shape of outer ring outside surface	No symbol	Cylindrical outer ring
	R	Crowned outer ring

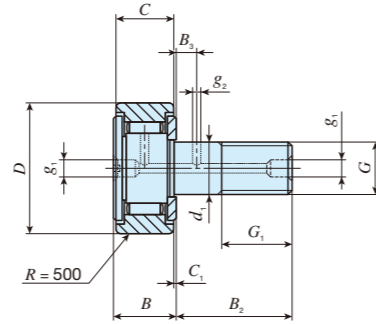
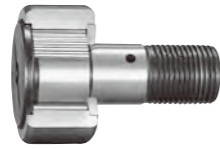

CR...VR

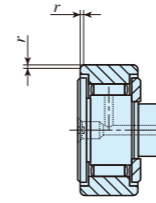

CR...V

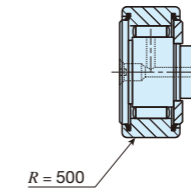

CR...VUUR

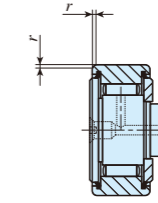

CR...VUU

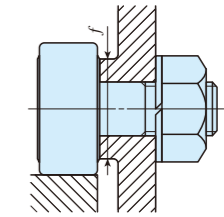

Stud diameter mm (inch)	Identification number				Mass (Ref.) g	Boundary dimensions mm (inch)											Mounting dimensions f mm (inch)	Maximum tightening torque N·m	Basic dynamic load rating C N	Basic static load rating C ₀ N	Track capacity				
	Shield type		Sealed type			D	C	d ₁	G UNF	G ₁	B max	B ₂	B ₃	C ₁	g ₁	g ₂					r	N	N	N	
	Crowned outer ring	Cylindrical outer ring	Crowned outer ring	Cylindrical outer ring																				Crowned outer ring	Cylindrical outer ring
4.826	CR 8 VR	CR 8 V	CR 8 VUUR	CR 8 VUU	9	12.700 (1/2)	8.731 (1/2)	4.826	No.10-32	6.350 (1/4)	10.2 (0.40)		12.700 (1/2)	— (—)	0.794 (1/32)	3.175 (1/8)	— (—)	0.397 (1/64)	8.334 (2/64)	1.4	4 260	4 750	770	2 140	
	CR 8-1 VR	CR 8-1 V	CR 8-1 VUUR	CR 8-1 VUU	10	12.700 (1/2)	9.525 (3/8)	4.826	No.10-32	6.350 (1/4)	10.9 (0.43)		15.875 (3/8)	— (—)	0.794 (1/32)	3.175 (1/8)	— (—)	0.397 (1/64)	8.334 (2/64)	1.4	4 710	5 410	770	2 360	
6.350 (1/4)	CR 10 VR	CR 10 V	CR 10 VUUR	CR 10 VUU	19	15.875 (3/8)	10.319 (1/2)	6.350 (1/4)	1/4 - 28	7.938 (3/16)	11.8 (0.46)		15.875 (3/8)	— (—)	0.794 (1/32)	3.175 (1/8)	— (—)	0.397 (1/64)	11.509 (2/64)	3.4	5 830	7 660	1 030	3 210	
	CR 10-1 VR	CR 10-1 V	CR 10-1 VUUR	CR 10-1 VUU	21	15.875 (3/8)	11.112 (7/16)	6.350 (1/4)	1/4 - 28	7.938 (3/16)	12.5 (0.49)		19.050 (3/4)	— (—)	0.794 (1/32)	3.175 (1/8)	— (—)	0.397 (1/64)	11.509 (2/64)	3.4	6 340	8 530	1 030	3 480	
9.525 (3/8)	CR 12 VR	CR 12 V	CR 12 VUUR	CR 12 VUU	36	19.050 (3/4)	12.700 (1/2)	9.525 (3/8)	3/8 - 24	9.525 (3/8)	14.2 (0.56)		22.225 (7/8)	6.350 (1/4)	0.794 (1/32)	4.762 (3/16)	2.381 (3/32)	0.794 (1/32)	13.494 (1/2)	10.8	8 710	12 300	1 340	4 500	
	CR 14 VR	CR 14 V	CR 14 VUUR	CR 14 VUU	47	22.225 (7/8)	12.700 (1/2)	9.525 (3/8)	3/8 - 24	9.525 (3/8)	14.2 (0.56)		22.225 (7/8)	6.350 (1/4)	0.794 (1/32)	4.762 (3/16)	2.381 (3/32)	0.794 (1/32)	15.081 (1/2)	10.8	8 710	12 300	1 630	5 250	
11.112 (7/16)	CR 16 VR	CR 16 V	CR 16 VUUR	CR 16 VUU	74	25.400 (1)	15.875 (3/8)	11.112 (7/16)	1/2 - 20	12.700 (1/2)	17.3 (0.68)		25.400 (1)	6.350 (1/4)	0.794 (1/32)	4.762 (3/16)	3.175 (1/8)	1.191 (3/64)	17.859 (5/64)	17.4	13 100	22 700	1 970	7 280	
	CR 18 VR	CR 18 V	CR 18 VUUR	CR 18 VUU	85	28.575 (1 1/8)	15.875 (3/8)	11.112 (7/16)	1/2 - 20	12.700 (1/2)	17.3 (0.68)		25.400 (1)	6.350 (1/4)	0.794 (1/32)	4.762 (3/16)	3.175 (1/8)	1.588 (1/16)	19.050 (3/4)	17.4	13 100	22 700	2 300	7 710	
12.700 (1/2)	CR 20 VR	CR 20 V	CR 20 VUUR	CR 20 VUU	137	31.750 (1 1/4)	19.050 (3/4)	12.700 (1/2)	1/2 - 20	15.875 (3/8)	20.4 (0.80)		31.750 (1 1/4)	7.938 (5/16)	0.794 (1/32)	4.762 (3/16)	3.175 (1/8)	1.588 (1/16)	21.828 (55/64)	27.7	23 600	31 700	2 680	10 700	
	CR 22 VR	CR 22 V	CR 22 VUUR	CR 22 VUU	160	34.925 (1 3/8)	19.050 (3/4)	12.700 (1/2)	1/2 - 20	15.875 (3/8)	20.4 (0.80)		31.750 (1 1/4)	7.938 (5/16)	0.794 (1/32)	4.762 (3/16)	3.175 (1/8)	1.588 (1/16)	21.828 (55/64)	27.7	23 600	31 700	3 050	11 800	
15.875 (5/8)	CR 24 VR	CR 24 V	CR 24 VUUR	CR 24 VUU	230	38.100 (1 1/2)	22.225 (7/8)	15.875 (3/8)	5/8 - 18	19.050 (3/4)	23.6 (0.93)		38.100 (1 1/2)	9.525 (3/8)	0.794 (1/32)	4.762 (3/16)	3.969 (5/32)	1.588 (1/16)	26.196 (1 3/64)	55.7	28 200	40 100	3 410	15 400	
	CR 26 VR	CR 26 V	CR 26 VUUR	CR 26 VUU	265	41.275 (1 5/8)	22.225 (7/8)	15.875 (3/8)	5/8 - 18	19.050 (3/4)	23.6 (0.93)		38.100 (1 1/2)	9.525 (3/8)	0.794 (1/32)	4.762 (3/16)	3.969 (5/32)	1.588 (1/16)	26.196 (1 3/64)	55.7	28 200	40 100	3 820	16 700	
19.050 (3/4)	CR 28 VR	CR 28 V	CR 28 VUUR	CR 28 VUU	372	44.450 (1 3/4)	25.400 (1)	19.050 (3/4)	3/4 - 16	22.225 (7/8)	26.8 (1.06)		44.450 (1 3/4)	11.112 (7/16)	0.794 (1/32)	4.762 (3/16)	3.969 (5/32)	1.588 (1/16)	32.543 (1 5/32)	100	35 300	55 600	4 210	21 000	
	CR 30 VR	CR 30 V	CR 30 VUUR	CR 30 VUU	418	47.625 (1 7/8)	25.400 (1)	19.050 (3/4)	3/4 - 16	22.225 (7/8)	26.8 (1.06)		44.450 (1 3/4)	11.112 (7/16)	0.794 (1/32)	4.762 (3/16)	3.969 (5/32)	1.588 (1/16)	32.543 (1 5/32)	100	35 300	55 600	4 610	22 500	
22.225 (7/8)	CR 32 VR	CR 32 V	CR 32 VUUR	CR 32 VUU	627	50.800 (2)	31.750 (1 1/4)	22.225 (7/8)	7/8 - 14	25.400 (1)	33.5 (1.32)		50.800 (2)	12.700 (1/2)	0.794 (1/32)	4.762 (3/16)	4.762 (3/16)	1.588 (1/16)	37.306 (1 15/32)	162	45 700	80 600	5 050	30 900	
	CR 36 VR	CR 36 V	CR 36 VUUR	CR 36 VUU	759	57.150 (2 1/4)	31.750 (1 1/4)	22.225 (7/8)	7/8 - 14	25.400 (1)	33.5 (1.32)		50.800 (2)	12.700 (1/2)	0.794 (1/32)	4.762 (3/16)	4.762 (3/16)	1.588 (1/16)	37.306 (1 15/32)	162	45 700	80 600	5 900	34 700	
31.750 (1 1/4)	—	—	—	CR 48 VUU	1 960	76.200 (3)	44.450 (1 3/4)	31.750 (1 1/4)	1 3/4 - 12	31.750 (1 1/4)	46.4 (1.83)		63.500 (2 1/2)	15.875 (3/8)	1.588 (1/16)	6.350 (1/4)	4.762 (3/16)	2.381 (3/32)	51.991 (2 3/64)	500	77 600	172 000	—	64 300	

Remarks 1. An oil hole is provided only for the stud head if the stud diameter d_1 is 6.35 mm or less. As for the others, an oil hole is provided for the head, the outside surface, and the end of the stud.
 2. Provided with pre-packed grease.
 3. Contact **IKO** for the information on the maximum allowable static load.

Selectable product specifications

Type of material	No symbol High carbon steel	F Stainless steel
Roller guide method	No symbol With cage	V Full complement
Seal structure	No symbol Shield type	UU Sealed type
Shape of outer ring outside surface	No symbol Cylindrical outer ring	R Crowned outer ring

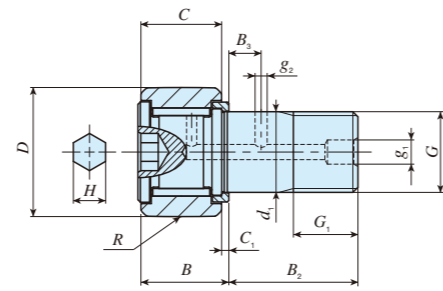
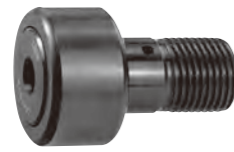

CRH...VBR

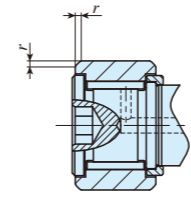

CRH...VB

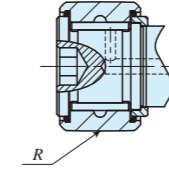

CRH...VBUUR

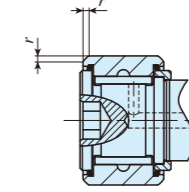

CRH...VBUU

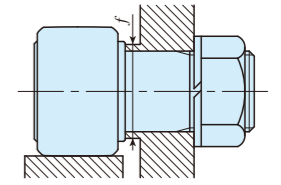

Stud diameter mm (inch)	Identification number				Mass (Ref.) g	Boundary dimensions mm (inch)														Mounting dimensions f mm (inch)	Maximum tightening torque N·m	Basic dynamic load rating C N	Basic static load rating C ₀ N	Track capacity N																		
	Shield type		Sealed type			D	C	d ₁	G UNF	G ₁	B max	B ₂	B ₃	C ₁	g ₁	g ₂	H	R	r					Crowned outer ring	Cylindrical outer ring																	
6.350 (1/4)	CRH 8-1 VBR	CRH 8-1 VB	CRH 8-1 VBUUR	CRH 8-1 VBUU	12	12.700 (1/2)	9.525 (3/8)	6.350 (1/4)	1/4 - 28	6.350 (1/4)	11.0 (0.44)																															
	CRH 9 VBR	CRH 9 VB	CRH 9 VBUUR	CRH 9 VBUU	15	14.288 (9/16)	9.525 (3/8)	6.350 (1/4)	1/4 - 28	6.350 (1/4)	11.1 (0.44)																															
7.938 (5/16)	CRH 10-1 VBR	CRH 10-1 VB	CRH 10-1 VBUUR	CRH 10-1 VBUU	23	15.875 (5/8)	11.112 (7/16)	7.938 (5/16)	5/16 - 24	7.938 (5/16)	12.8 (0.50)																															
	CRH 11 VBR	CRH 11 VB	CRH 11 VBUUR	CRH 11 VBUU	27	17.462 (11/16)	11.112 (7/16)	7.938 (5/16)	5/16 - 24	7.938 (5/16)	12.8 (0.50)																															
11.112 (7/16)	CRH 12 VBR	CRH 12 VB	CRH 12 VBUUR	CRH 12 VBUU	39	19.050 (3/4)	12.700 (1/2)	11.112 (7/16)	7/16 - 20	9.525 (3/8)	14.6 (0.57)																															
	CRH 14 VBR	CRH 14 VB	CRH 14 VBUUR	CRH 14 VBUU	49	22.225 (7/8)	12.700 (1/2)	11.112 (7/16)	7/16 - 20	9.525 (3/8)	14.6 (0.57)																															
15.875 (5/8)	CRH 16 VBR	CRH 16 VB	CRH 16 VBUUR	CRH 16 VBUU	93	25.400 (1)	15.875 (5/8)	15.875 (5/8)	5/8 - 18	12.700 (1/2)	17.9 (0.70)																															
	CRH 18 VBR	CRH 18 VB	CRH 18 VBUUR	CRH 18 VBUU	109	28.575 (1 1/8)	15.875 (5/8)	15.875 (5/8)	5/8 - 18	12.700 (1/2)	17.9 (0.70)																															
19.050 (3/4)	CRH 20 VBR	CRH 20 VB	CRH 20 VBUUR	CRH 20 VBUU	176	31.750 (1 1/4)	19.050 (3/4)	19.050 (3/4)	3/4 - 16	15.875 (5/8)	21.0 (0.83)																															
	CRH 22 VBR	CRH 22 VB	CRH 22 VBUUR	CRH 22 VBUU	200	34.925 (1 3/8)	19.050 (3/4)	19.050 (3/4)	3/4 - 16	15.875 (5/8)	21.0 (0.83)																															
22.225 (7/8)	CRH 24 VBR	CRH 24 VB	CRH 24 VBUUR	CRH 24 VBUU	296	38.100 (1 1/2)	22.225 (7/8)	22.225 (7/8)	7/8 - 14	19.050 (3/4)	24.3 (0.96)																															
	CRH 26 VBR	CRH 26 VB	CRH 26 VBUUR	CRH 26 VBUU	329	41.275 (1 5/8)	22.225 (7/8)	22.225 (7/8)	7/8 - 14	19.050 (3/4)	24.3 (0.96)																															
25.400 (1)	CRH 28 VBR	CRH 28 VB	CRH 28 VBUUR	CRH 28 VBUU	463	44.450 (1 3/4)	25.400 (1)	25.400 (1)	1 - 14UNS	22.225 (7/8)	27.4 (1.08)																															
	CRH 30 VBR	CRH 30 VB	CRH 30 VBUUR	CRH 30 VBUU	508	47.625 (1 7/8)	25.400 (1)	25.400 (1)	1 - 14UNS	22.225 (7/8)	27.4 (1.08)																															
28.575 (1 1/8)	CRH 32 VBR	CRH 32 VB	CRH 32 VBUUR	CRH 32 VBUU	722	50.800 (2)	31.750 (1 1/4)	28.575 (1 1/8)	1 1/8 - 12	25.400 (1)	34.2 (1.35)																															
	CRH 36 VBR	CRH 36 VB	CRH 36 VBUUR	CRH 36 VBUU	858	57.150 (2 1/4)	31.750 (1 1/4)	28.575 (1 1/8)	1 1/8 - 12	25.400 (1)	34.2 (1.35)																															
31.750 (1 1/4)	CRH 40 VBR	CRH 40 VB	CRH 40 VBUUR	CRH 40 VBUU	1 260	63.500 (2 1/2)	38.100 (1 1/2)	31.750 (1 1/4)	1 1/4 - 12	28.575 (1 1/8)	40.0 (1.57)																															
	CRH 44 VBR	CRH 44 VB	CRH 44 VBUUR	CRH 44 VBUU	1 460	69.850 (2 3/4)	38.100 (1 1/2)	31.750 (1 1/4)	1 1/4 - 12	28.575 (1 1/8)	40.0 (1.57)																															
38.100 (1 1/2)	CRH 48 VBR	CRH 48 VB	CRH 48 VBUUR	CRH 48 VBUU	2 100	76.200 (3)	44.450 (1 3/4)	38.100 (1 1/2)	1 1/2 - 12	31.750 (1 1/4)	46.4 (1.83)																															
	CRH 52 VBR	CRH 52 VB	CRH 52 VBUUR	CRH 52 VBUU	2 380	82.500 (3 1/8)	44.450 (1 3/4)	38.100 (1 1/2)	1 1/2 - 12	31.750 (1 1/4)	46.4 (1.83)																															
44.450 (1 3/4)	CRH 56 VBR	CRH 56 VB	CRH 56 VBUUR	CRH 56 VBUU	3 240	88.900 (3 1/2)	50.800 (2)	44.450 (1 3/4)	1 3/4 - 12UN	34.925 (1 3/8)	52.8 (2.08)																															
50.800 (2)	CRH 64 VBR	CRH 64 VB	CRH 64 VBUUR	CRH 64 VBUU	4 960	101.600 (4)	57.150 (2 1/4)	50.800 (2)	2 - 12UN	38.100 (1 1/2)	59.4 (2.34)																															

Remarks 1. No oil hole is provided if the stud diameter d_1 is 7.938 mm or less. As for the others, an oil hole is provided for the head, the outside surface, and the end of the stud.
 2. Provided with pre-packed grease.
 3. Contact **IKO** for the information on the maximum allowable static load.

Selectable product specifications

Type of material	No symbol	High carbon steel
	F	Stainless steel
Roller guide method	No symbol	With cage
	V	Full complement
Seal structure	No symbol	Shield type
	UU	Sealed type
Shape of outer ring outside surface	No symbol	Cylindrical outer ring
	R	Crowned outer ring

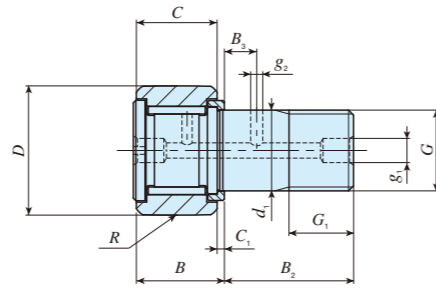

CRH...VR

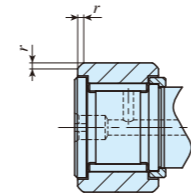

CRH...V

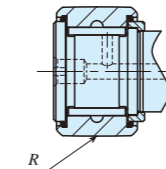

CRH...VUUR

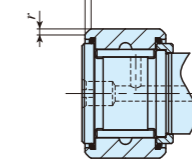

CRH...VUU

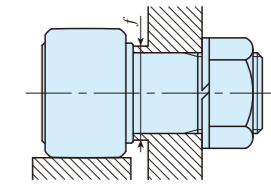

Stud diameter mm (inch)	Identification number				Mass (Ref.) g	Boundary dimensions mm (inch)											Mounting dimensions f Min. mm (inch)	Maximum tightening torque N·m	Basic dynamic load rating C N	Basic static load rating C ₀ N	Track capacity N			
	Shield type		Sealed type			D	C	d ₁	G UNF	G ₁	B max	B ₂	B ₃	C ₁	g ₁	g ₂					R	r	Crowned outer ring	Cylindrical outer ring
	Crowned outer ring	Cylindrical outer ring	Crowned outer ring	Cylindrical outer ring																				
6.350 (1/4)	CRH 8-1 VR	CRH 8-1 V	CRH 8-1 VUUR	CRH 8-1 VUU	12	12.700 (1/2)	9.525 (3/8)	6.350 (1/4)	1/4 - 28	6.350 (1/4)	11.0 (0.44)							8.334 (2/64)	3.4	4 710	5 410	401	2 360	
	CRH 9 VR	CRH 9 V	CRH 9 VUUR	CRH 9 VUU	15	14.288 (9/16)	9.525 (3/8)	6.350 (1/4)	1/4 - 28	6.350 (1/4)	11.1 (0.44)							8.334 (2/64)	3.4	4 710	5 410	469	2 650	
7.938 (5/16)	CRH 10-1 VR	CRH 10-1 V	CRH 10-1 VUUR	CRH 10-1 VUU	23	15.875 (5/8)	11.112 (7/16)	7.938 (5/16)	5/16 - 24	7.938 (5/16)	12.8 (0.50)							11.112 (7/16)	6.8	6 340	8 530	579	3 480	
	CRH 11 VR	CRH 11 V	CRH 11 VUUR	CRH 11 VUU	27	17.462 (11/16)	11.112 (7/16)	7.938 (5/16)	5/16 - 24	7.938 (5/16)	12.8 (0.50)							11.112 (7/16)	6.8	6 340	8 530	658	3 830	
11.112 (7/16)	CRH 12 VR	CRH 12 V	CRH 12 VUUR	CRH 12 VUU	39	19.050 (3/4)	12.700 (1/2)	11.112 (7/16)	7/16 - 20	9.525 (3/8)	14.6 (0.57)							13.494 (1/2)	17.6	8 710	12 300	853	4 500	
	CRH 14 VR	CRH 14 V	CRH 14 VUUR	CRH 14 VUU	49	22.225 (7/8)	12.700 (1/2)	11.112 (7/16)	7/16 - 20	9.525 (3/8)	14.6 (0.57)							13.494 (1/2)	17.6	8 710	12 300	1 050	5 250	
15.875 (5/8)	CRH 16 VR	CRH 16 V	CRH 16 VUUR	CRH 16 VUU	93	25.400 (1)	15.875 (5/8)	15.875 (5/8)	5/8 - 18	12.700 (1/2)	17.9 (0.70)							18.256 (9/32)	57.8	13 100	22 700	1 420	7 280	
	CRH 18 VR	CRH 18 V	CRH 18 VUUR	CRH 18 VUU	109	28.575 (1 1/8)	15.875 (5/8)	15.875 (5/8)	5/8 - 18	12.700 (1/2)	17.9 (0.70)							18.256 (9/32)	57.8	13 100	22 700	1 660	7 710	
19.050 (3/4)	CRH 20 VR	CRH 20 V	CRH 20 VUUR	CRH 20 VUU	176	31.750 (1 1/4)	19.050 (3/4)	19.050 (3/4)	3/4 - 16	15.875 (5/8)	21.0 (0.83)							24.209 (9/16)	103	23 600	31 700	2 160	10 700	
	CRH 22 VR	CRH 22 V	CRH 22 VUUR	CRH 22 VUU	200	34.925 (1 3/8)	19.050 (3/4)	19.050 (3/4)	3/4 - 16	15.875 (5/8)	21.0 (0.83)							24.209 (9/16)	103	23 600	31 700	2 450	11 800	
22.225 (7/8)	CRH 24 VR	CRH 24 V	CRH 24 VUUR	CRH 24 VUU	296	38.100 (1 1/2)	22.225 (7/8)	22.225 (7/8)	7/8 - 14	19.050 (3/4)	24.3 (0.96)							26.988 (1 1/16)	162	28 200	40 100	3 410	15 400	
	CRH 26 VR	CRH 26 V	CRH 26 VUUR	CRH 26 VUU	329	41.275 (1 5/8)	22.225 (7/8)	22.225 (7/8)	7/8 - 14	19.050 (3/4)	24.3 (0.96)							26.988 (1 1/16)	162	28 200	40 100	3 820	16 700	
25.400 (1)	CRH 28 VR	CRH 28 V	CRH 28 VUUR	CRH 28 VUU	463	44.450 (1 3/4)	25.400 (1)	25.400 (1)	1 - 14UNS	22.225 (7/8)	27.4 (1.08)							32.941 (1 9/16)	258	35 300	55 600	4 210	21 000	
	CRH 30 VR	CRH 30 V	CRH 30 VUUR	CRH 30 VUU	508	47.625 (1 7/8)	25.400 (1)	25.400 (1)	1 - 14UNS	22.225 (7/8)	27.4 (1.08)							32.941 (1 9/16)	258	35 300	55 600	4 610	22 500	
28.575 (1 1/8)	CRH 32 VR	CRH 32 V	CRH 32 VUUR	CRH 32 VUU	722	50.800 (2)	31.750 (1 1/4)	28.575 (1 1/8)	1 1/8 - 12	25.400 (1)	34.2 (1.35)							37.306 (1 15/16)	356	45 700	80 600	5 690	30 900	
	CRH 36 VR	CRH 36 V	CRH 36 VUUR	CRH 36 VUU	858	57.150 (2 1/4)	31.750 (1 1/4)	28.575 (1 1/8)	1 1/8 - 12	25.400 (1)	34.2 (1.35)							37.306 (1 15/16)	356	45 700	80 600	6 640	34 700	
31.750 (1 1/4)	CRH 40 VR	CRH 40 V	CRH 40 VUUR	CRH 40 VUU	1 260	63.500 (2 1/2)	38.100 (1 1/2)	31.750 (1 1/4)	1 1/4 - 12	28.575 (1 1/8)	40.0 (1.57)							40.878 (1 3/8)	500	61 400	116 000	8 970	45 000	
	CRH 44 VR	CRH 44 V	CRH 44 VUUR	CRH 44 VUU	1 460	69.850 (2 3/4)	38.100 (1 1/2)	31.750 (1 1/4)	1 1/4 - 12	28.575 (1 1/8)	40.0 (1.57)							40.878 (1 3/8)	500	61 400	116 000	10 200	49 500	
38.100 (1 1/2)	CRH 48 VR	CRH 48 V	CRH 48 VUUR	CRH 48 VUU	2 100	76.200 (3)	44.450 (1 3/4)	38.100 (1 1/2)	1 1/2 - 12	31.750 (1 1/8)	46.4 (1.83)							51.991 (2 3/16)	892	77 600	172 000	11 400	64 300	
	CRH 52 VR	CRH 52 V	CRH 52 VUUR	CRH 52 VUU	2 380	82.500 (3 1/4)	44.450 (1 3/4)	38.100 (1 1/2)	1 1/2 - 12	31.750 (1 1/8)	46.4 (1.83)							51.991 (2 3/16)	892	77 600	172 000	12 700	69 600	
44.450 (1 3/4)	CRH 56 VR	CRH 56 V	CRH 56 VUUR	CRH 56 VUU	3 240	88.900 (3 1/2)	50.800 (2)	44.450 (1 3/4)	1 3/4 - 12UN	34.925 (1 3/8)	52.8 (2.08)							59.928 (2 3/16)	1 450	111 000	239 000	14 100	87 000	
50.800 (2)	CRH 64 VR	CRH 64 V	CRH 64 VUUR	CRH 64 VUU	4 960	101.600 (4)	57.150 (2 1/4)	50.800 (2)	2 - 12UN	38.100 (1 1/2)	59.4 (2.34)							64.691 (2 5/16)	2 190	142 000	317 000	16 800	113 000	

Remarks 1. An oil hole is provided only for the stud head if the stud diameter d₁ is 7.938 mm or less. As for the others, an oil hole is provided for the head, the outside surface, and the end of the stud.
 2. Provided with pre-packed grease.
 3. Contact **IKO** for the information on the maximum allowable static load.

Way for Cam Follower

The accuracy of the mating cam guide that comes in contact with the outer ring of Cam Followers has a large influence on the guide performance of Cam Followers and machinery.

A specially designed high-precision Way for Cam Follower should be used in order to achieve sufficient performance from the Cam Followers. Fixed with bolts for simple assembly and available in 2 models - A type or B type - depending on the mounting direction.

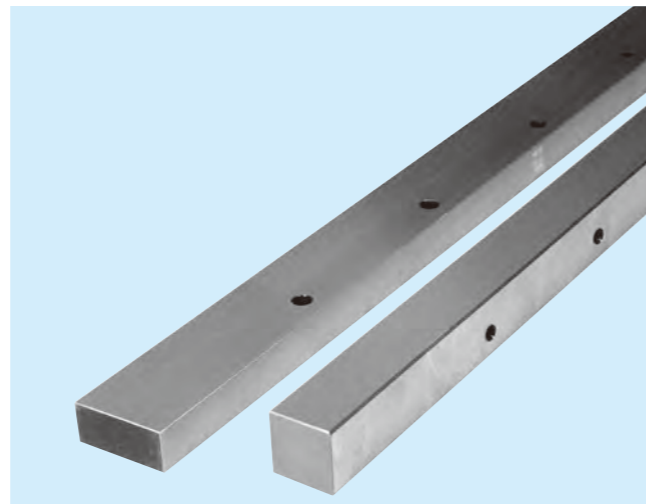

<Way A Type>

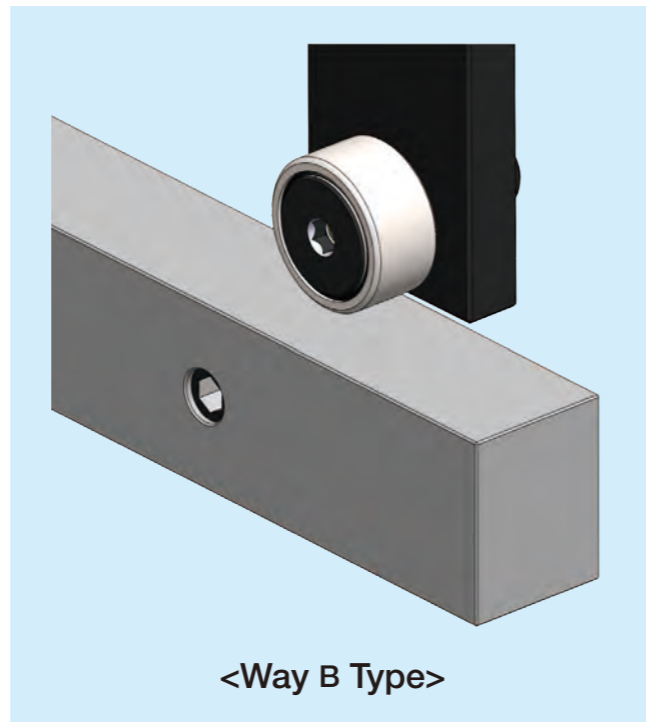

<Way B Type>

1 Identification Number

Example of the identification number of Way for Cam Follower is shown below.

TRLA - 800 - 49 - 22

Model code
TRLA (Way A Type)
TRLB (Way B Type)

Overall length
 mm

Width
 mm

Height
 mm

2 Dimension Table

<Way A Type>

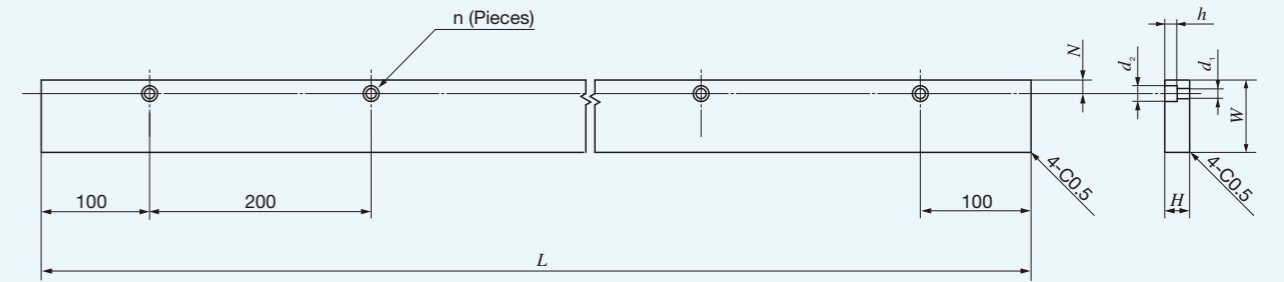

Material: SKS3 equivalent
 Surface hardness: HRC40 or more

Identification number	Boundary dimensions mm							Applicable Cam Followers
	L (n)	W	H	N	d ₁	d ₂	h	
TRLA- 600-40-22	600 (3)	40	22	12	9	14	11	Stud dia. 3 to 8 mm
TRLA- 800-40-22	800 (4)							
TRLA-1000-40-22	1000 (5)							
TRLA- 600-49-22	600 (3)	49	22	12	9	14	11	Stud dia. 10 to 18 mm
TRLA- 800-49-22	800 (4)							
TRLA-1000-49-22	1000 (5)							
TRLA- 600-64-22	600 (3)	64	22	12	9	14	11	Stud dia. 20 to 30 mm
TRLA- 800-64-22	800 (4)							
TRLA-1000-64-22	1000 (5)							

Remark For other dimensions, please contact **IKO**.

<Way B Type>

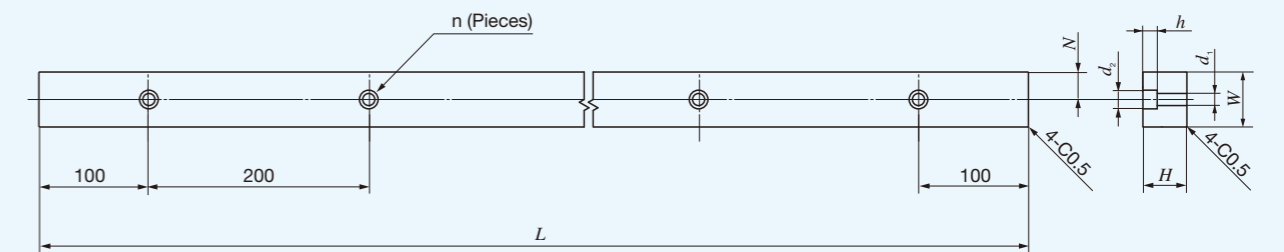

Material: SKS3 equivalent
 Surface hardness: HRC40 or more

Identification number	Boundary dimensions mm							Applicable Cam Followers
	L (n)	W	H	N	d ₁	d ₂	h	
TRLB- 600-34-22	600 (3)	34	22	17	9	14	11	Stud dia. 3 to 12 mm
TRLB- 800-34-22	800 (4)							
TRLB-1000-34-22	1000 (5)							
TRLB- 600-50-40	600 (3)	50	40	25	11	17	13	Stud dia. 16 to 30 mm
TRLB- 800-50-40	800 (4)							
TRLB-1000-50-40	1000 (5)							

Remark For other dimensions, please contact **IKO**.

Introduction of Special Support Examples

Introducing special support examples of Way for Cam Follower.
A variety of shapes are supported. For details, please contact **IKO**.

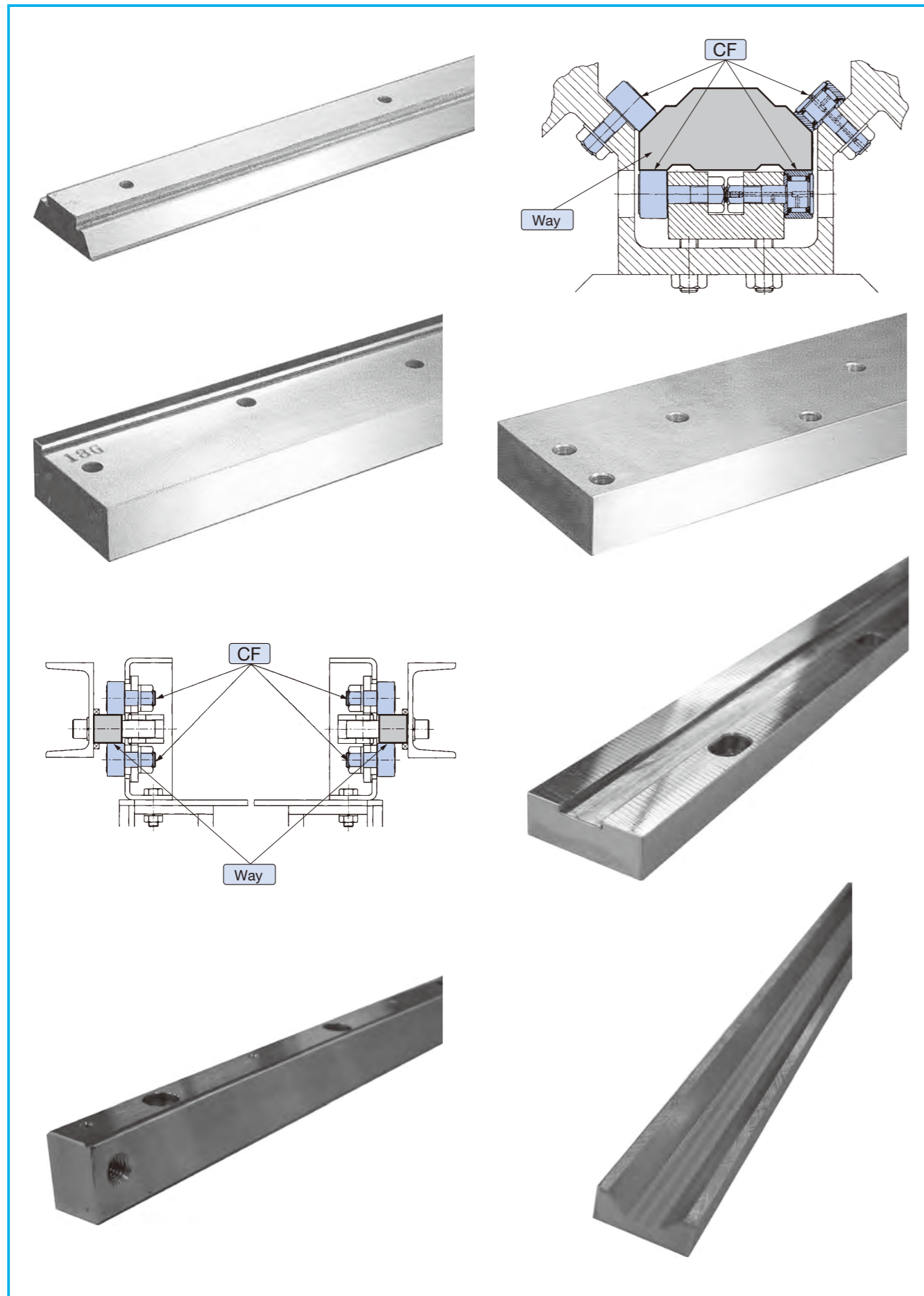

Roller Follower Series

Explanation	
Features	77
Identification number	79
Load Rating and Life	80
Maximum Allowable Static Load	80
Accuracy	81
Radial Internal Clearance	82
Fit	83
Track Capacity	83
Allowable Rotational Speed	83
Lubrication	83
Oil Hole	83
Operating Temperature Range	83
Mounting	84

Dimension Table	
Separable Roller Followers	85
Non-separable Roller Followers	89
C-Lube Roller Followers	93
Cylindrical Roller Followers	95
Inch Series Non-separable Roller Followers	97

IKO Roller Followers European RoHS Compliant Products

IKO Roller Followers are bearings with needle rollers in the thick outer ring and designed for rotation of the outer ring.

There are separable/non-separable models, Cylindrical Roller Followers, and other models. Roller Followers are widely used as follower bearings of various cam mechanisms and guide rollers for linear motion of conveying equipment.

Side plate
Quench-hardened for increased wear resistance.

Inner ring
The outer peripheral faces of the needle rollers are finished with high accuracy that contributes to a long life.

Outer ring
Adopts a thick shape and realizes resistance to shock loads.

Needle roller
Adopts a crowning roller contributing to resistance to shock loads.

Cage
Separable types use a needle roller cage for excellent high-speed rotation.

Seal
Completely sealed to prevent foreign substances entering the bearing.

Roller Followers

C-Lube Roller Followers

NART.../SG

The space inside IKO the bearings of Non-separable Roller Followers is filled with C-Lube, a unique thermal setting solid lubricant, achieving a maintenance free product.

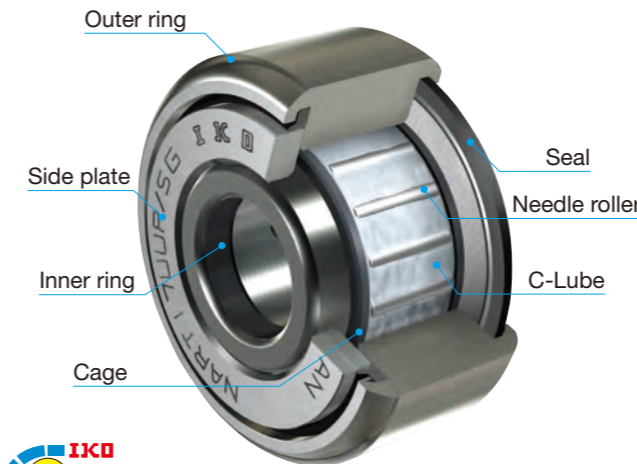

Features

1. Less lubrication oil used
Periodic lubrication is not required, leading to a reduction in the amount of lubrication oil used. This simultaneously reduces the number of lubrication mechanisms.

2. Ideal for oil-free applications
Lubrication oil is retained within the bearing without leakage, preventing oil from being scattered and dirtying the surrounding environment.

3. Lubrication device cost reduction
Lubrication devices are not necessary, eliminating the device installation and running costs. Furthermore, the space otherwise occupied with lubrication devices can be utilized effectively.

Selectable product specifications

Type of material	No symbol	High carbon steel
	F	Stainless steel
Roller guide method	No symbol	With cage
	V	Full complement
Seal structure	No symbol	Shield type
	UU	Sealed type
Shape of outer ring outside surface	No symbol	Cylindrical outer ring
	R	Crowned outer ring

Separable Roller Followers

NAST

This type has a structure combining the outer ring, the inner ring, and the needle roller cage and offers excellent high-speed rotation performance. In addition, each part is separable and easily handled. There are two types: type without inner ring RNAS and type with inner ring NAST.

Selectable product specifications

Type of material	No symbol	High carbon steel
	F	Stainless steel
Roller guide method	No symbol	With cage
	V	Full complement
Seal structure	No symbol	Open type
	ZZ	Shield type
	ZZUU	Sealed type
Shape of outer ring outside surface	No symbol	Cylindrical outer ring
	R	Crowned outer ring

Non-separable Roller Followers

NART

High carbon steel made
Stainless steel made

These non-separable type bearings have side plates fixed on both sides of the inner ring. Caged type and full complement type are available for your use. Materials can be selected and the stainless steel Roller Followers are superior in corrosion resistance and suitable for applications in environments where oil cannot be used or where water splashes, and in clean-rooms.

Selectable product specifications

Type of material	No symbol	High carbon steel
	F	Stainless steel
Roller guide method	No symbol	With cage
	V	Full complement
Seal structure	No symbol	Shield type
	UU	Sealed type
Shape of outer ring outside surface	No symbol	Cylindrical outer ring
	R	Crowned outer ring

Cylindrical Roller Followers

NURT

These bearings are full complement type bearings incorporating double rows of full complement cylindrical rollers in the outer ring, and can withstand large radial loads and some axial loads.

Selectable product specifications

Type of material	No symbol	High carbon steel
	F	Stainless steel
Roller guide method	No symbol	Full complement
Seal structure	No symbol	Shield type
	UU	Sealed type
Shape of outer ring outside surface	No symbol	Cylindrical outer ring
	R	Crowned outer ring

Inch Series Roller Followers

CRY

These are NART Inch Series Roller Followers with black oxide film treatment.

Selectable product specifications

Type of material	No symbol	High carbon steel
	F	Stainless steel
Roller guide method	No symbol	With cage
	V	Full complement
Seal structure	No symbol	Shield type
	UU	Sealed type
Shape of outer ring outside surface	No symbol	Cylindrical outer ring
	R	Crowned outer ring

Identification Number

Examples of the identification number of Roller Followers are shown below. In addition, for application of roller guide method, seal structure and shape of outer ring outside surface to each model, refer to the dimension table.

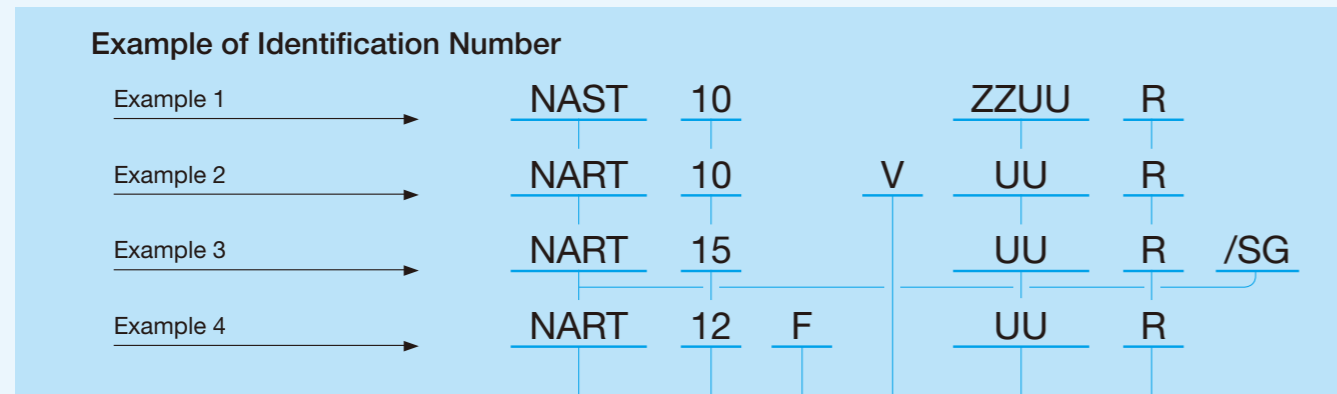

Model code			
Metric series	RNAST	Separable Roller Followers	Without inner ring
	NAST	Separable Roller Followers	With inner ring
	NART	Non-separable Roller Followers	
	NART.../SG	C-Lube Roller Followers	
	NURT	Cylindrical Roller Followers	
Inch series	CRY	Non-separable Roller Followers	

Dimensions	
The size indicates the bore diameter of the inner ring. (unit: mm)	
In the inch series, the outer diameter of the outer ring is indicated in units of 1/16 inch.	

Type of material	
No symbol	High carbon steel made
F ⁽¹⁾	Stainless steel made

Roller guide method	
No symbol	With cage
V	Full complement

Seal Structure (Separable Roller Follower)	
No symbol	Open type
ZZ	Shield type
ZZUU	Sealed type

Seal Structure (Other Roller Followers)	
No symbol	Shield type
UU	Sealed type

Shape of outer ring outside surface	
R	Crowned outer ring
No symbol	Cylindrical outer ring

Note (1) Applicable to Non-separable Roller Followers only

Load Rating and Life

Basic dynamic load rating C

Basic dynamic load rating refers to a static radial load with a certain direction and size with which 90% of a group of the same Roller Followers can run one million rotations without material damages due to rolling contact fatigue when they are operated in the same conditions.

Basic static load rating C_0

Basic static load rating refers to a static radial load with a certain direction and size with a certain contact stress at the center of contact parts of the rolling elements and a raceway under maximum load.

Life

The basic rating life calculation formulas are shown below.

$$L_{10} = \left(\frac{C}{P_r}\right)^{10/3} \dots\dots\dots (1)$$

Where, L_{10} : Basic rating life 10^6 rev.
 C : Basic dynamic load rating N
 P_r : Dynamic equivalent radial load N

Therefore, life time can be calculated by applying the rotational speed to the formula below.

$$L_h = \frac{10^6 L_{10}}{60n} \dots\dots\dots (2)$$

Where, L_h : Basic rating life represented by service hours h
 n : Rotational speed min^{-1}

Static Safety Factor

Static safety factor can be obtained by the following equation and typical values are shown in Table 1.

$$f_s = \frac{C_0}{P_{or}} \dots\dots\dots (3)$$

Where, f_s : Static safety factor
 C_0 : Basic static load rating N
 P_{or} : Static equivalent radial load (maximum load) N

Table 1 Static safety factor

Bearing use conditions	f_s
When high rotational accuracy is required	≥ 3
For ordinary operation conditions	≥ 1.5
When smooth operations are not required with a high priority under normal operating conditions When it is rarely rotated	≥ 1

Load factor

Actual load applied on the Roller Followers becomes larger than load theoretically calculated from vibration and shock. Therefore, multiply the load by the load factor shown in Table 2.

Table 2 Load factor

Degree of load	f_w
Smooth operation free from shock	1 to 1.2
Normal operation	1.2 to 1.5
Operation with shock load	1.5 to 3

Maximum Allowable Static Load

The applicable load on Roller Followers is, in some cases, limited by the strength of the outer ring instead of the load rating of the needle roller bearing. Therefore, the maximum allowable static load that is limited by these strengths is specified.

Accuracy

The accuracy of Roller Followers is shown in Table 3, Table 4.1, Table 4.2, and Table 4.3. Tolerances for the smallest single roller set bore diameter of Separable Roller Followers are shown in Table 5. We also provide special accuracy class product. For details, please contact **IKO**.

Table 3 Tolerances

Item	Series	Metric series		Inch series	
		Crowned outer ring	Cylindrical outer ring	Crowned outer ring	Cylindrical outer ring
Bore dia. of inner ring d	$d \leq 19.05$	See Table 4.1		+ 5 - 10	+ 5 - 10
	$19.05 < d$			+ 2 - 12	
Outside dia. of outer ring D		0 -50	See Table 4.2	0 -50	See Table 4.3
Width of outer ring C		0 -120		0 -130	
Width of inner ring B	Separable Roller Followers	0 -120		-	
Width of bearing B	Non-separable Roller Followers	h12	-	+130	
	Cylindrical Roller Followers		h12	-250	
Roller set bore dia. F_w	Separable Roller Followers	See Table 5		-	

unit: μm

Table 4.1 Tolerance and allowance of inner ring (Metric series)

d Nominal bore diameter mm	Δd_{mp} Deviation of mean bore diameter in a single plane		V_{dsp} Variation of bore diameter in a single plane (Maximum)	V_{dmp} Variation of mean bore diameter (Maximum)	K_{ia} Radial runout of inner ring of assembled bearing (Maximum)	V_{Bs} Variation of inner ring width (Maximum)	
	Over	Incl.					High
2.5	10	0	- 8	10	6	10	15
10	18	0	- 8	10	6	10	20
18	30	0	-10	13	8	13	20
30	50	0	-12	15	9	15	20

unit: μm

Table 4.2 Tolerance and allowance of outer ring (Metric series, Cylindrical outer ring)

D Nominal outside diameter of outer ring mm	ΔD_{mp} Deviation of mean outside diameter in a single plane		V_{Dsp} Variation of outside diameter in a single plane (Maximum)	V_{Dmp} Variation of mean outside diameter (Maximum)	K_{ea} Radial runout of outer ring of assembled bearing (Maximum)	V_{Cs} Variation of outer ring width (Maximum)
	Over	Incl.				
6	18	0	- 8	10	6	15
18	30	0	- 9	12	7	15
30	50	0	-11	14	8	20
50	80	0	-13	16	10	25
80	120	0	-15	19	11	35

unit: μm

See the allowance of V_{Bs} for the same bearing d .

Table 4.3 Tolerance and allowance of outer ring (Inch series, Cylindrical outer ring)

unit: μm

D Nominal outside diameter of outer ring mm	ΔD_{mp} Deviation of mean outside diameter in a single plane		V_{Dsp} Variation of outside diameter in a single plane (Maximum)	V_{Dmp} Variation of mean outside diameter (Maximum)	K_{ea} Radial runout of outer ring of assembled bearing (Maximum)	
	Over	Incl.				High
6	18	0	-25	10	6	15
18	30			12	7	15
30	50			14	8	20
50	80			16	10	25
80	120			19	11	35

Table 5 Tolerances of smallest single roller set bore diameter $F_{ws\ min}$

unit: μm

F_w Nominal roller set bore diameter mm	$\Delta F_{ws\ min}$ Deviation of smallest single roller set bore diameter		
	Over	Incl.	High
6	10	+22	+13
10	18	+27	+16
18	30	+33	+20
30	50	+41	+25
50	80	+49	+30

Radial Internal Clearance

Radial internal clearance of Roller Followers is shown in Table 6.

Table 6 Radial internal clearance

unit: μm

Identification number (1)				Radial internal clearance	
Metric series		Inch series		Min.	Max.
Separable Roller Followers	Non-separable Roller Followers (2)	Cylindrical Roller Followers	Non-separable Roller Followers		
NAST 6R	NART 5R	-	-	5	20
NAST 8R to NAST12R	NART 6R to NART12R	-	-	5	25
NAST15R to NAST25R	NART15R to NART20R	-	-	10	30
NAST30R to NAST40R	NART25R to NART40R	-	-	10	40
NAST45R, NAST50R	NART45R, NART50R	-	-	15	50
-	-	NURT15R to NURT30-1R	-	20	45
-	-	NURT35R to NURT40-1R	-	25	50
-	-	NURT45R to NURT50-1R	-	30	60
-	-	-	CRY12R to CRY56R	35	60
-	-	-	CRY64R	45	70

Note (1) Also applicable to the type with full complement, the shield and sealed types, and the cylindrical outer ring.

Note (2) Also applicable to C-Lube Roller Followers.

Fit

Roller Followers are generally used for outer ring rotation load. A recommended fit with a shaft is shown in Table 7. Those for the inch series are shown in the dimension table.

Table 7 Recommended fit (metric series)

Model of bearing	Tolerance class of shaft	
Separable Roller Followers	Without inner ring	k5, k6
	With inner ring	g6, h6
Non-separable Roller Followers (*)		
Cylindrical Roller Followers		

Note (*) Also applicable to C-Lube Roller Followers.

Track Capacity

Track capacity is defined as the load which can be continuously applied on a Roller Follower placed on a steel cam guide surface without causing deformation or indentation on the cam guide surface when the outer ring of the Roller Follower makes contact with the mating cam guide surface (plane). Track capacities shown in the dimension table are values on the assumption that hardness of the mating member material is 40HRC (tensile strength: 1250 N/mm²) and if hardness is not 40HRC, these values must be multiplied by track capacity factors shown in Table 8.

If lubrication between the outer ring and the mating cam guide surface is insufficient, seizure and/or wear may occur depending on the operating conditions. Therefore, attention must be paid to lubrication and surface roughness of the mating cam guide especially for high-speed rotations such as cam mechanisms.

Table 8 Track capacity factor

Hardness HRC	Tensile strength N/mm ²	Track capacity factor	
		Crowned outer ring	Cylindrical outer ring
20	760	0.22	0.37
25	840	0.31	0.46
30	950	0.45	0.58
35	1 080	0.65	0.75
38	1 180	0.85	0.89
40	1 250	1.00	1.00
42	1 340	1.23	1.15
44	1 435	1.52	1.32
46	1 530	1.85	1.51
48	1 635	2.27	1.73
50	1 760	2.80	1.99
52	1 880	3.46	2.29
54	2 015	4.21	2.61
56	2 150	5.13	2.97
58	2 290	6.26	3.39

Allowable Rotational Speed

The allowable rotational speed of Roller Followers is affected by mounting and operating conditions. For dn value with only pure radial load applied, use values in Table 9 or lower as references. Under actual use conditions, it is recommended to use dn , one tenth of indicated values, taking into account the effect of axial load. C-Lube Roller Followers, use 8,000 or lower as reference for the dn value.

Table 9 Roller Follower dn value (*)

Model of bearing	Lubrication	
	Grease lubrication	Oil lubrication
With cage	84 000	140 000
Full complement	42 000	70 000
Cylindrical Roller Followers	72 000	120 000

Note (*) dn value = $d \times n$
 where, d : Bearing inner diameter mm
 n : Rotational speed min⁻¹

Lubrication

In Sealed Type Roller Followers, Cylindrical Roller Followers and Inch Series Roller Followers, ALVANIA GREASE S2 (SHOWA SHELL SEKIYU K.K.) is pre-packed as the lubrication grease.

For bearings without pre-packed grease, grease or oil should be supplied through the oil hole of the inner ring for use. Operating without lubrication will increase the wear on the rolling contact surfaces and lead to short bearing life.

Oil Hole

Open Type Separable Roller Followers have no oil hole. Inner rings of other types of Metric series Roller Followers have an oil hole. Inch series inner rings have an oil groove and an oil hole.

Operating Temperature Range

Operating temperature range of Roller Followers is -20°C to +120°C.

Please use C-Lube Roller Followers at a bearing temperature between -15°C and +80°C. For continuous operation, the recommended operating temperature is +60°C or less.

Mounting

Notes about mounts

In case of shield and sealed types, match the side surface correctly to the mating seating surface indicated by the dimension a shown in the dimension table, and fix them. (See Fig. 1)

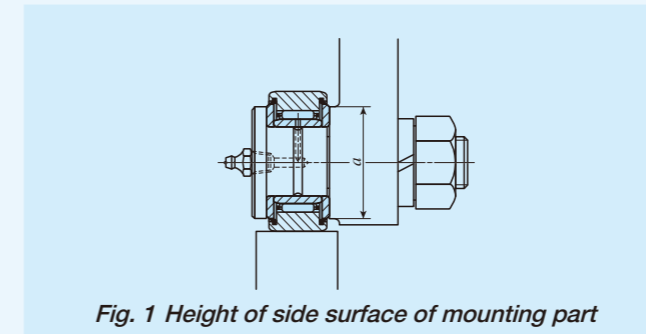

Notes about oil hole position and loading direction

When mounting Roller Followers, pay special attention to avoid locating the oil hole of the inner ring within the loading zone. Otherwise, product life may become shorter. (See Fig. 2)

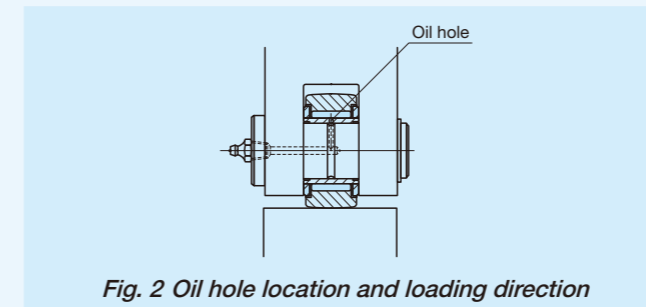

Mounting methods for Separable Roller Followers

When mounting Sealed Type Separable Roller Followers, do not cause the side plates to come off. If they come off, set the seal lip into the side plate again, taking care to avoid damaging the seal lips. (See Fig. 3)

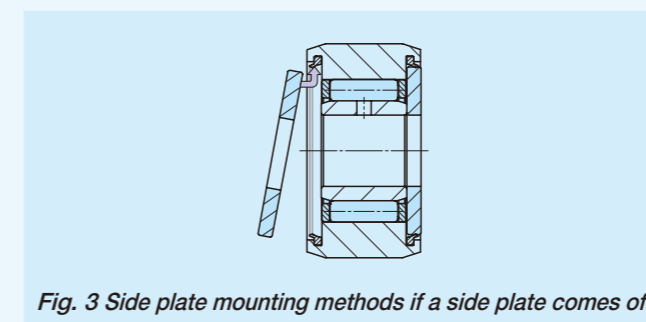

Mounting methods for bearings without inner rings

In case of Roller Followers without inner ring, the shaft requires heat treatment and grinding finish. At this time, the shaft surface hardness of 58 to 64 HRC and the shaft surface roughness of 0.2 μmR_a or less is recommended. Also, the outer ring and cage are guided by side surfaces of the mounting parts. Therefore, it is recommended that the side surfaces of the mounting parts be finished by grinding or at least by machining. (See Fig. 4)

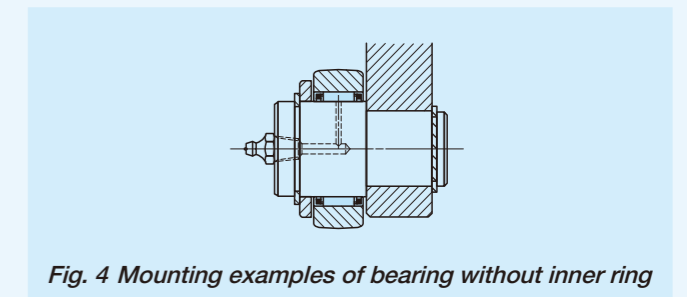

Mounting methods for Non-Separable Roller Followers

Mount in accordance with Fig. 5 when inserting Non-Separable Roller Followers into the shaft. Pushing on the side plates or outer rings may cause unsatisfactory product performance.

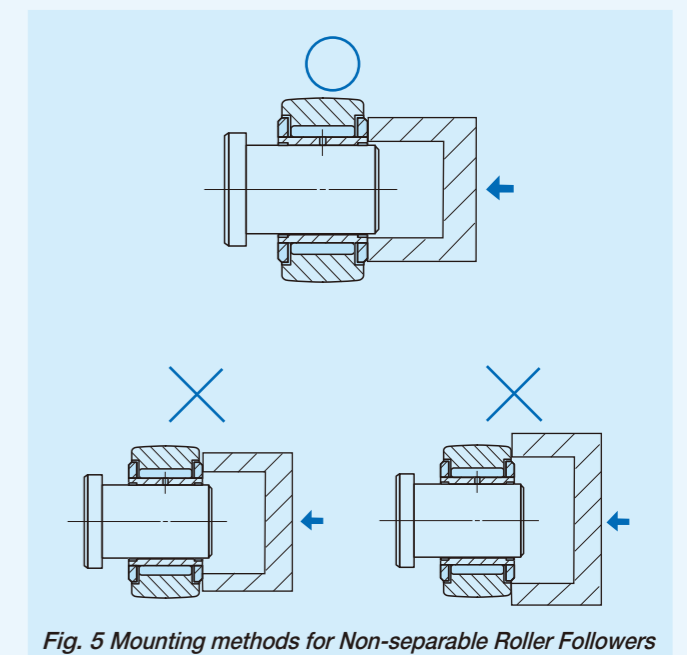

Selectable product specifications

Type of material	No symbol	High carbon steel
	F	Stainless steel
Roller guide method	No symbol	With cage
	V	Full complement
Seal structure	No symbol	Open type
	ZZ	Shield type
	ZZUU	Sealed type
Shape of outer ring outside surface	No symbol	Cylindrical outer ring
	R	Crowned outer ring

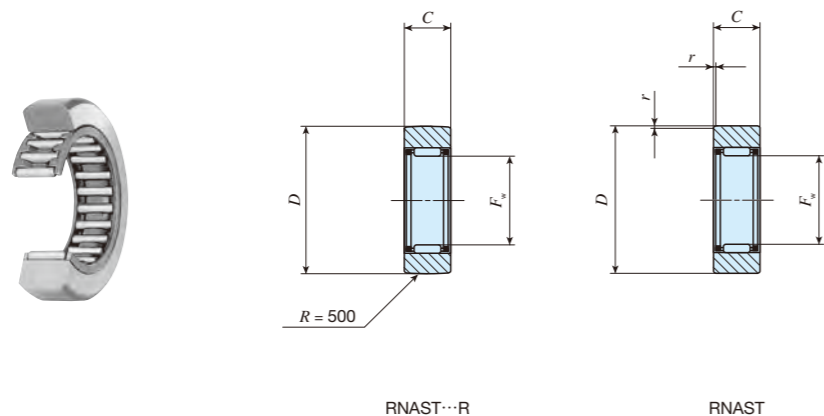

Selectable product specifications

Type of material	No symbol	High carbon steel
	F	Stainless steel
Roller guide method	No symbol	With cage
	V	Full complement
Seal structure	No symbol	Open type
	ZZ	Shield type
	ZZUU	Sealed type
Shape of outer ring outside surface	No symbol	Cylindrical outer ring
	R	Crowned outer ring

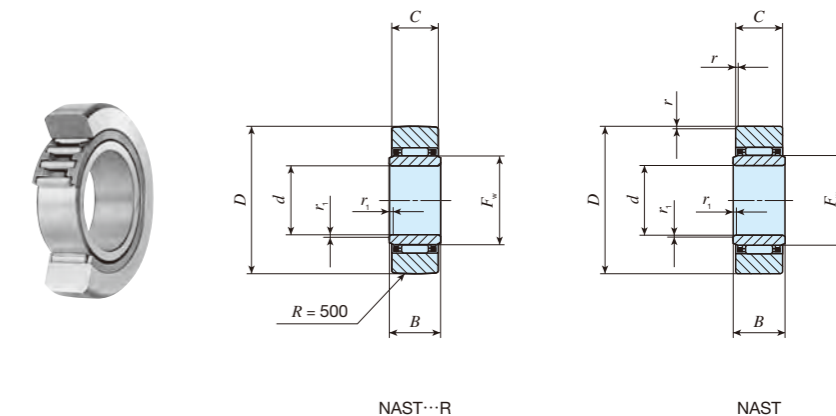

Shaft diameter mm	Identification number		Mass (Ref.) g	Boundary dimensions mm				Basic dynamic load rating C N	Basic static load rating C ₀ N	Track capacity N	
	Open type			F _w	D	C	r _{s min} ⁽¹⁾			Crowned outer ring	Cylindrical outer ring
	Crowned outer ring	Cylindrical outer ring									
7	RNAST 5 R	RNAST 5	8.9	7	16	7.8	0.3	2 710	2 390	1 040	2 310
10	RNAST 6 R	RNAST 6	13.9	10	19	9.8	0.3	4 160	4 550	1 330	3 550
12	RNAST 8 R	RNAST 8	23.5	12	24	9.8	0.6	5 650	5 890	1 850	3 980
14	RNAST 10 R	RNAST 10	42.5	14	30	11.8	1	9 790	9 680	2 470	5 610
16	RNAST 12 R	RNAST 12	49.5	16	32	11.8	1	10 500	10 900	2 710	5 990
20	RNAST 15 R	RNAST 15	50	20	35	11.8	1	12 400	14 300	3 060	6 550
22	RNAST 17 R	RNAST 17	90	22	40	15.8	1	17 600	20 900	3 660	10 900
25	RNAST 20 R	RNAST 20	135	25	47	15.8	1	19 400	24 500	4 530	12 800
30	RNAST 25 R	RNAST 25	152	30	52	15.8	1	20 800	28 400	5 190	14 100
38	RNAST 30 R	RNAST 30	255	38	62	19.8	1	30 500	45 400	6 580	22 100
42	RNAST 35 R	RNAST 35	375	42	72	19.8	1	32 400	50 600	8 020	25 700
50	RNAST 40 R	RNAST 40	420	50	80	19.8	1.5	35 900	61 100	9 220	26 900
55	RNAST 45 R	RNAST 45	460	55	85	19.8	1.5	37 400	66 400	9 990	28 500
60	RNAST 50 R	RNAST 50	500	60	90	19.8	1.5	38 900	71 700	10 800	30 200

Note (1) Minimum allowable value of the chamfer dimension r.
 Remark 1. No oil hole is provided.
 2. Not provided with pre-packed grease. Perform proper lubrication for use.

Shaft diameter mm	Identification number		Mass (Ref.) g	Boundary dimensions mm							Basic dynamic load rating C N	Basic static load rating C ₀ N	Built-in inner ring	Track capacity N	
	Open type			d	D	B	C	r _{s min} ⁽¹⁾	r _{s min} ⁽¹⁾	F _w				Crowned outer ring	Cylindrical outer ring
	Crowned outer ring	Cylindrical outer ring													
6	NAST 6 R	NAST 6	17.8	6	19	10	9.8	0.3	0.3	10	4 160	4 550	LRT 61010 S	1 330	3 550
8	NAST 8 R	NAST 8	28	8	24	10	9.8	0.6	0.3	12	5 650	5 890	LRT 81210 S	1 850	3 980
10	NAST 10 R	NAST 10	49.5	10	30	12	11.8	1	0.3	14	9 790	9 680	LRT 101412 S	2 470	5 610
12	NAST 12 R	NAST 12	58	12	32	12	11.8	1	0.3	16	10 500	10 900	LRT 121612 S	2 710	5 990
15	NAST 15 R	NAST 15	62	15	35	12	11.8	1	0.3	20	12 400	14 300	LRT 152012 S	3 060	6 550
17	NAST 17 R	NAST 17	109	17	40	16	15.8	1	0.3	22	17 600	20 900	LRT 172216 S	3 660	10 900
20	NAST 20 R	NAST 20	157	20	47	16	15.8	1	0.3	25	19 400	24 500	LRT 202516 S	4 530	12 800
25	NAST 25 R	NAST 25	180	25	52	16	15.8	1	0.3	30	20 800	28 400	LRT 253016 S	5 190	14 100
30	NAST 30 R	NAST 30	320	30	62	20	19.8	1	0.6	38	30 500	45 400	LRT 303820 S	6 580	22 100
35	NAST 35 R	NAST 35	440	35	72	20	19.8	1	0.6	42	32 400	50 600	LRT 354220 S	8 020	25 700
40	NAST 40 R	NAST 40	530	40	80	20	19.8	1.5	1	50	35 900	61 100	LRT 405020 S	9 220	26 900
45	NAST 45 R	NAST 45	580	45	85	20	19.8	1.5	1	55	37 400	66 400	LRT 455520 S	9 990	28 500
50	NAST 50 R	NAST 50	635	50	90	20	19.8	1.5	1	60	38 900	71 700	LRT 506020 S	10 800	30 200

Note (1) Minimum allowable value of chamfer dimension r or r₁.
 Remark 1. No oil hole is provided.
 2. Not provided with pre-packed grease. Perform proper lubrication for use.

IKO Separable Roller Followers / Shield Type / With Inner Ring Separable Roller Followers / Sealed Type / With Inner Ring

Selectable product specifications

Type of material	No symbol	High carbon steel
	F	Stainless steel
Roller guide method	No symbol	With cage
	V	Full complement
Seal structure	No symbol	Open type
	ZZ	Shield type
	ZZUU	Sealed type
Shape of outer ring outside surface	No symbol	Cylindrical outer ring
	R	Crowned outer ring

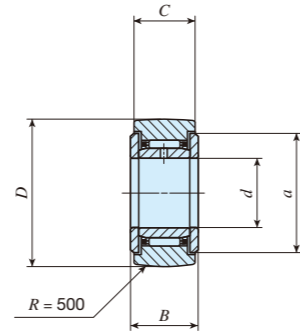

NAST...ZZR

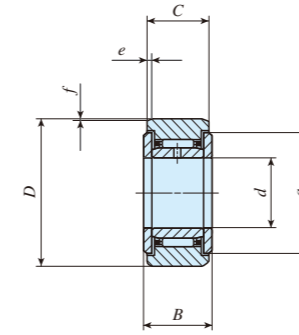

NAST...ZZ

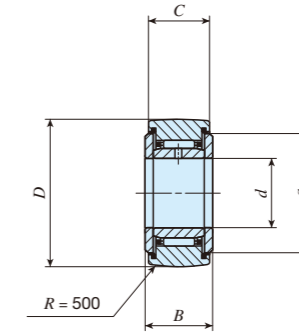

NAST...ZZUUR

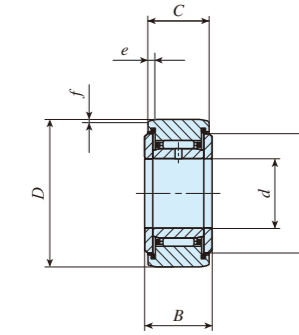

NAST...ZZUU

Shaft diameter mm	Identification number				Mass (Ref.) g	Boundary dimensions mm							Basic dynamic load rating C N	Basic static load rating C ₀ N	Track capacity N	
	Shield type		Sealed type			d	D	B	C	a	e	f			Crowned outer ring	Cylindrical outer ring
	Crowned outer ring	Cylindrical outer ring	Crowned outer ring	Cylindrical outer ring												
6	NAST 6 ZZR	NAST 6 ZZ	NAST 6 ZZUUR	NAST 6 ZZUU	24.5	6	19	14	13.8	14	2.5	0.8	4 160	4 550	1 330	3 550
8	NAST 8 ZZR	NAST 8 ZZ	NAST 8 ZZUUR	NAST 8 ZZUU	39	8	24	14	13.8	17.5	2.5	0.8	5 650	5 890	1 850	4 490
10	NAST 10 ZZR	NAST 10 ZZ	NAST 10 ZZUUR	NAST 10 ZZUU	65	10	30	16	15.8	23.5	2.5	0.8	9 790	9 680	2 470	6 890
12	NAST 12 ZZR	NAST 12 ZZ	NAST 12 ZZUUR	NAST 12 ZZUU	75	12	32	16	15.8	25.5	2.5	0.8	10 500	10 900	2 710	7 350
15	NAST 15 ZZR	NAST 15 ZZ	NAST 15 ZZUUR	NAST 15 ZZUU	83	15	35	16	15.8	29	2.5	0.8	12 400	14 300	3 060	8 030
17	NAST 17 ZZR	NAST 17 ZZ	NAST 17 ZZUUR	NAST 17 ZZUU	135	17	40	20	19.8	32.5	3	1	17 600	20 900	3 660	11 700
20	NAST 20 ZZR	NAST 20 ZZ	NAST 20 ZZUUR	NAST 20 ZZUU	195	20	47	20	19.8	38	3	1	19 400	24 500	4 530	13 800
25	NAST 25 ZZR	NAST 25 ZZ	NAST 25 ZZUUR	NAST 25 ZZUU	225	25	52	20	19.8	43	3	1	20 800	28 400	5 190	15 300
30	NAST 30 ZZR	NAST 30 ZZ	NAST 30 ZZUUR	NAST 30 ZZUU	400	30	62	25	24.8	50.5	4	1.2	30 500	45 400	6 580	22 100
35	NAST 35 ZZR	NAST 35 ZZ	NAST 35 ZZUUR	NAST 35 ZZUU	550	35	72	25	24.8	53.5	4	1.2	32 400	50 600	8 020	25 700
40	NAST 40 ZZR	NAST 40 ZZ	NAST 40 ZZUUR	NAST 40 ZZUU	710	40	80	26	25.8	61.5	4	1.2	35 900	61 100	9 220	30 300
45	NAST 45 ZZR	NAST 45 ZZ	NAST 45 ZZUUR	NAST 45 ZZUU	760	45	85	26	25.8	66.5	4	1.2	37 400	66 400	9 990	32 200
50	NAST 50 ZZR	NAST 50 ZZ	NAST 50 ZZUUR	NAST 50 ZZUU	830	50	90	26	25.8	76	4	1.2	38 900	71 700	10 800	34 000

Remark 1. The inner ring has an oil hole.

2. Grease is pre-packed for the sealed type. Shield type is not provided with pre-packed grease. Perform proper lubrication for use.

Selectable product specifications

Type of material	No symbol	High carbon steel
	F	Stainless steel
Roller guide method	No symbol	With cage
	V	Full complement
Seal structure	No symbol	Shield type
	UU	Sealed type
Shape of outer ring outside surface	No symbol	Cylindrical outer ring
	R	Crowned outer ring

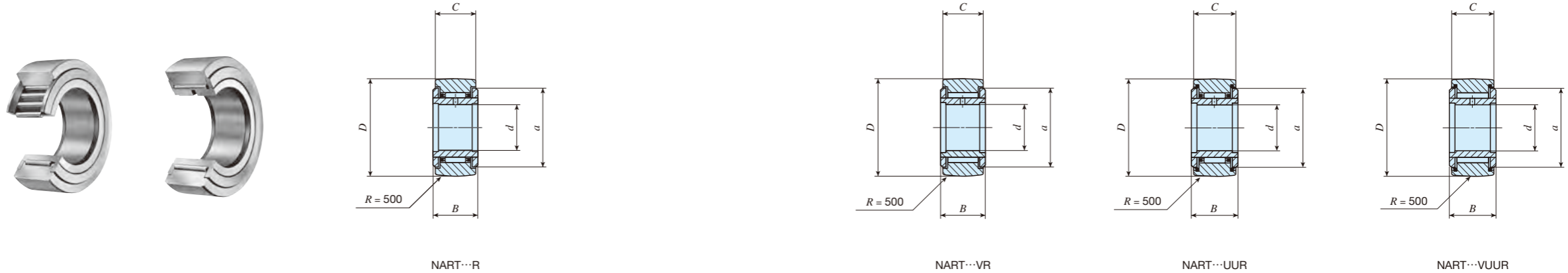

Shaft diameter mm	Identification number				Mass (Ref.) g	Boundary dimensions mm					Basic dynamic load rating C N	Basic static load rating C ₀ N	Maximum allowable static load N	Track capacity N
	Shield type Crowned outer ring		Sealed type Crowned outer ring			d	D	B	C	a				
	With cage	Full complement	With cage	Full complement										
5	NART 5 R	—	NART 5 UUR	—	14.5	5	16	12	11	12	3 650	3 680	3 680	1 040
	—	NART 5 VR	—	NART 5 VUUR	15.1	5	16	12	11	12	6 810	8 370	7 310	1 040
6	NART 6 R	—	NART 6 UUR	—	20.5	6	19	12	11	14	4 250	4 740	4 740	1 330
	—	NART 6 VR	—	NART 6 VUUR	21.5	6	19	12	11	14	7 690	10 300	10 300	1 330
8	NART 8 R	—	NART 8 UUR	—	41.5	8	24	15	14	17.5	5 640	5 900	5 900	1 850
	—	NART 8 VR	—	NART 8 VUUR	42.5	8	24	15	14	17.5	11 800	15 600	15 600	1 850
10	NART 10 R	—	NART 10 UUR	—	64.5	10	30	15	14	23.5	8 030	7 540	7 540	2 470
	—	NART 10 VR	—	NART 10 VUUR	66.5	10	30	15	14	23.5	15 600	18 100	17 500	2 470
12	NART 12 R	—	NART 12 UUR	—	71	12	32	15	14	25.5	8 580	8 470	8 470	2 710
	—	NART 12 VR	—	NART 12 VUUR	73	12	32	15	14	25.5	16 800	20 500	18 600	2 710
15	NART 15 R	—	NART 15 UUR	—	102	15	35	19	18	29	13 700	16 400	16 400	3 060
	—	NART 15 VR	—	NART 15 VUUR	106	15	35	19	18	29	25 200	36 400	24 000	3 060
17	NART 17 R	—	NART 17 UUR	—	149	17	40	21	20	32.5	17 600	21 000	21 000	3 660
	—	NART 17 VR	—	NART 17 VUUR	155	17	40	21	20	32.5	32 000	46 300	33 100	3 660
20	NART 20 R	—	NART 20 UUR	—	250	20	47	25	24	38	23 000	30 700	30 700	4 530
	—	NART 20 VR	—	NART 20 VUUR	255	20	47	25	24	38	41 600	67 300	67 300	4 530
25	NART 25 R	—	NART 25 UUR	—	285	25	52	25	24	43	24 700	35 400	35 400	5 190
	—	NART 25 VR	—	NART 25 VUUR	295	25	52	25	24	43	45 500	79 100	79 100	5 190
30	NART 30 R	—	NART 30 UUR	—	470	30	62	29	28	50.5	33 600	51 400	51 400	6 580
	—	NART 30 VR	—	NART 30 VUUR	485	30	62	29	28	50.5	59 900	110 000	92 500	6 580
35	NART 35 R	—	NART 35 UUR	—	640	35	72	29	28	53.5	35 700	57 400	57 400	8 020
	—	NART 35 VR	—	NART 35 VUUR	655	35	72	29	28	53.5	63 100	121 000	121 000	8 020
40	NART 40 R	—	NART 40 UUR	—	845	40	80	32	30	61.5	44 900	81 500	81 500	9 220
	—	NART 40 VR	—	NART 40 VUUR	865	40	80	32	30	61.5	76 300	164 000	164 000	9 220
45	NART 45 R	—	NART 45 UUR	—	915	45	85	32	30	66.5	46 800	88 600	88 600	9 990
	—	NART 45 VR	—	NART 45 VUUR	935	45	85	32	30	66.5	80 300	181 000	181 000	9 990
50	NART 50 R	—	NART 50 UUR	—	980	50	90	32	30	76	48 600	95 600	95 600	10 800
	—	NART 50 VR	—	NART 50 VUUR	1 010	50	90	32	30	76	84 300	198 000	198 000	10 800

Remark 1. The inner ring has an oil hole.
 2. Grease is pre-packed for the sealed type. Shield type is not provided with pre-packed grease. Perform proper lubrication for use.

Selectable product specifications

Type of material	No symbol	High carbon steel
	F	Stainless steel
Roller guide method	No symbol	With cage
	V	Full complement
Seal structure	No symbol	Shield type
	UU	Sealed type
Shape of outer ring outside surface	No symbol	Cylindrical outer ring
	R	Crowned outer ring

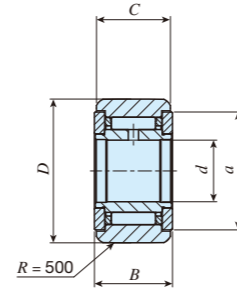

NART...FR

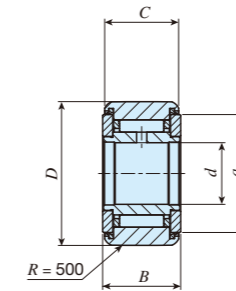

NART...FUUR

Shaft diameter mm	Identification number		Mass (Ref.) g	Boundary dimensions mm					Basic dynamic load rating C N	Basic static load rating C_0 N	Maximum allowable static load N	Track capacity N
	Shield type	Sealed type		d	D	B	C	a				
5	NART 5 FR	NART 5 FUUR	13	5	16	12	11	12	2 930	2 920	2 920	1 040
6	NART 6 FR	NART 6 FUUR	19	6	19	12	11	14	3 400	3 790	3 790	1 330
8	NART 8 FR	NART 8 FUUR	39	8	24	15	14	17.5	4 340	5 510	5 510	1 850
10	NART 10 FR	NART 10 FUUR	61	10	30	15	14	22.5	6 330	7 830	7 830	2 470
12	NART 12 FR	NART 12 FUUR	67	12	32	15	14	25.5	6 510	8 400	8 400	2 710
15	NART 15 FR	NART 15 FUUR	99	15	35	19	18	27.5	9 620	14 700	14 700	3 060
17	NART 17 FR	NART 17 FUUR	146	17	40	21	20	31	11 800	20 200	20 200	3 660
20	NART 20 FR	NART 20 FUUR	241	20	47	25	24	36.5	16 500	27 700	27 700	4 530
25	NART 25 FR	NART 25 FUUR	269	25	52	25	24	43	19 800	28 300	28 300	5 190
30	NART 30 FR	NART 30 FUUR	447	30	62	29	28	50	26 900	41 200	41 200	6 580

Remark 1. The inner ring has an oil hole.

2. Grease is pre-packed for the sealed type. Shield type is not provided with pre-packed grease. Perform proper lubrication for use.

Selectable product specifications

Type of material	No symbol	High carbon steel
	F	Stainless steel
Roller guide method	No symbol	With cage
	V	Full complement
Seal structure	No symbol	Shield type
	UU	Sealed type
Shape of outer ring outside surface	No symbol	Cylindrical outer ring
	R	Crowned outer ring

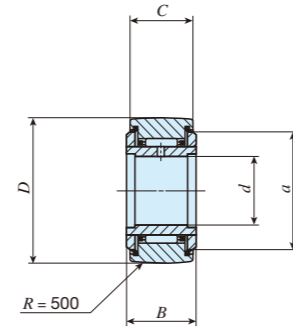

NART...UUR/SG

Shaft diameter mm	Identification number Sealed type	Mass (Ref.) g	Boundary dimensions mm					Basic dynamic load rating C N	Basic static load rating C_0 N	Maximum allowable static load N	Track capacity N
			d	D	B	C	a				
5	NART 5 UUR / SG	14.5	5	16	12	11	12	3 650	3 680	3 680	1 040
6	NART 6 UUR / SG	20.5	6	19	12	11	14	4 250	4 740	4 740	1 330
8	NART 8 UUR / SG	41.5	8	24	15	14	17.5	5 640	5 900	5 900	1 850
10	NART 10 UUR / SG	64.5	10	30	15	14	23.5	8 030	7 540	7 540	2 470
12	NART 12 UUR / SG	71	12	32	15	14	25.5	8 580	8 470	8 470	2 710
15	NART 15 UUR / SG	102	15	35	19	18	29	13 700	16 400	16 400	3 060
17	NART 17 UUR / SG	149	17	40	21	20	32.5	17 600	21 000	21 000	3 660
20	NART 20 UUR / SG	250	20	47	25	24	38	23 000	30 700	30 700	4 530

Remark This bearing cannot be re-lubricated as thermosetting solid-type lubricant C-Lube fills its inner space.

Selectable product specifications

Type of material	No symbol	High carbon steel
	F	Stainless steel
Roller guide method	No symbol	Full complement
Seal structure	No symbol	Shield type
	UU	Sealed type
Shape of outer ring outside surface	No symbol	Cylindrical outer ring
	R	Crowned outer ring

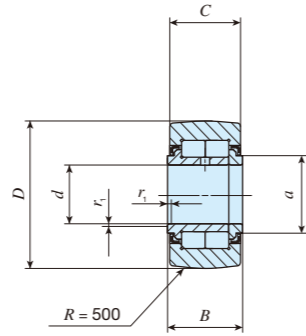

NURT...R

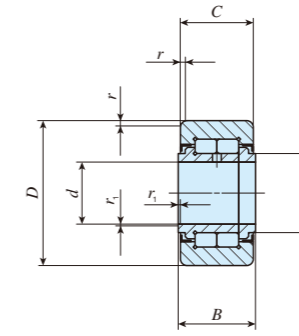

NURT

Shaft diameter mm	Identification number		Mass (Ref.) g	Boundary dimensions mm								Basic dynamic load rating C N	Basic static load rating C_0 N	Maximum allowable static load N	Track capacity N	
	Crowned outer ring	Cylindrical outer ring		d	D	B	C	a	$r_{s \min}^{(1)}$	$r_{1s \min}^{(1)}$	Crowned outer ring				Cylindrical outer ring	
15	NURT 15 R	NURT 15	100	15	35	19	18	20		0.6	0.3	23 400	27 300	11 800	3 060	11 500
	NURT 15-1 R	NURT 15-1	160	15	42	19	18	20		0.6	0.3	23 400	27 300	27 300	3 910	13 700
17	NURT 17 R	NURT 17	147	17	40	21	20	22		1	0.3	25 200	30 900	20 300	3 660	13 600
	NURT 17-1 R	NURT 17-1	222	17	47	21	20	22		1	0.3	25 200	30 900	30 900	4 530	16 000
20	NURT 20 R	NURT 20	245	20	47	25	24	27		1	0.3	38 900	49 000	27 200	4 530	20 000
	NURT 20-1 R	NURT 20-1	321	20	52	25	24	27		1	0.3	38 900	49 000	49 000	5 190	22 100
25	NURT 25 R	NURT 25	281	25	52	25	24	31		1	0.3	43 100	58 100	30 000	5 190	22 100
	NURT 25-1 R	NURT 25-1	450	25	62	25	24	31		1	0.3	43 100	58 100	58 100	6 580	26 400
30	NURT 30 R	NURT 30	466	30	62	29	28	38		1	0.3	58 200	75 300	35 200	6 580	31 600
	NURT 30-1 R	NURT 30-1	697	30	72	29	28	38		1	0.3	58 200	75 300	75 300	8 020	36 700
35	NURT 35 R	NURT 35	630	35	72	29	28	44		1	0.6	63 900	88 800	57 000	8 020	36 700
	NURT 35-1 R	NURT 35-1	840	35	80	29	28	44		1	0.6	63 900	88 800	88 800	9 220	40 800
40	NURT 40 R	NURT 40	817	40	80	32	30	49		1	0.6	86 500	122 000	75 300	9 220	44 200
	NURT 40-1 R	NURT 40-1	1 130	40	90	32	30	49		1	0.6	86 500	122 000	122 000	10 800	49 700
45	NURT 45 R	NURT 45	883	45	85	32	30	53		1	0.6	91 500	135 000	78 700	9 990	47 000
	NURT 45-1 R	NURT 45-1	1 400	45	100	32	30	53		1	0.6	91 500	135 000	135 000	12 400	55 300
50	NURT 50 R	NURT 50	950	50	90	32	30	58		1	0.6	96 300	148 000	82 100	10 800	49 700
	NURT 50-1 R	NURT 50-1	1 690	50	110	32	30	58		1	0.6	96 300	148 000	148 000	14 000	60 800

Note (1) Minimum allowable value of chamfer dimension r or r_1 .

Remark 1. The inner ring has an oil hole.

2. Provided with pre-packed grease.

Selectable product specifications

Type of material	No symbol	High carbon steel
	F	Stainless steel
Roller guide method	No symbol	With cage
	V	Full complement
Seal structure	No symbol	Shield type
	UU	Sealed type
Shape of outer ring outside surface	No symbol	Cylindrical outer ring
	R	Crowned outer ring

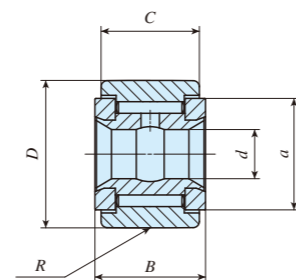

CRY...VR

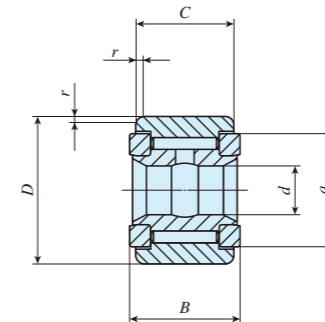

CRY...V

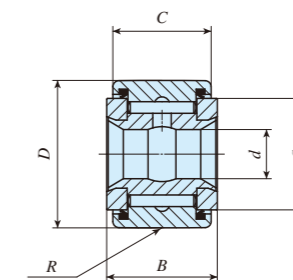

CRY...VUUR

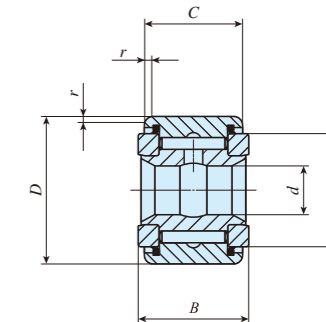

CRY...VUU

Shaft diameter mm (inch)	Identification number				Mass (Ref.) g	Boundary dimensions mm (inch)								Shaft diameter mm						Basic dynamic load rating C N	Basic static load rating C ₀ N	Track capacity N	
	Shield type		Sealed type			d	D	B	C	a	R	r	Clearance fit		Transition fit		Interference fit		Crowned outer ring			Cylindrical outer ring	
	Crowned outer ring	Cylindrical outer ring	Crowned outer ring	Cylindrical outer ring									Min.	Max.	Min.	Max.	Min.	Max.					
6.350 ($\frac{1}{4}$)	CRY 12 VR	CRY 12 V	CRY 12 VUUR	CRY 12 VUU	27	6.350 ($\frac{1}{4}$)	19.050 ($\frac{3}{4}$)	14.288 (0.5625)	12.700 ($\frac{1}{2}$)		14.4 (0.567)	250 (10)	0.794 ($\frac{1}{32}$)	6.332	6.342	6.348	6.358	6.353	6.363	8 710	12 300	853	4 490
	CRY 14 VR	CRY 14 V	CRY 14 VUUR	CRY 14 VUU	36	6.350 ($\frac{1}{4}$)	22.225 ($\frac{7}{8}$)	14.288 (0.5625)	12.700 ($\frac{1}{2}$)		14.4 (0.567)	250 (10)	0.794 ($\frac{1}{32}$)	6.332	6.342	6.348	6.358	6.353	6.363	8 710	12 300	1 050	5 240
7.938 ($\frac{5}{16}$)	CRY 16 VR	CRY 16 V	CRY 16 VUUR	CRY 16 VUU	68	7.938 ($\frac{5}{16}$)	25.400 (1)	17.463 (0.6875)	15.875 ($\frac{5}{8}$)		19.6 (0.772)	300 (12)	1.191 ($\frac{3}{16}$)	7.920	7.930	7.935	7.945	7.940	7.950	13 100	22 700	1 420	7 270
	CRY 18 VR	CRY 18 V	CRY 18 VUUR	CRY 18 VUU	77	7.938 ($\frac{5}{16}$)	28.575 (1 $\frac{1}{8}$)	17.463 (0.6875)	15.875 ($\frac{5}{8}$)		19.6 (0.772)	300 (12)	1.588 ($\frac{1}{16}$)	7.920	7.930	7.935	7.945	7.940	7.950	13 100	22 700	1 660	7 700
9.525 ($\frac{3}{8}$)	CRY 20 VR	CRY 20 V	CRY 20 VUUR	CRY 20 VUU	109	9.525 ($\frac{3}{8}$)	31.750 (1 $\frac{1}{4}$)	20.638 (0.8125)	19.050 ($\frac{3}{4}$)		25.0 (0.984)	360 (14)	1.588 ($\frac{1}{16}$)	9.507	9.517	9.523	9.533	9.528	9.538	23 600	31 700	2 160	10 700
	CRY 22 VR	CRY 22 V	CRY 22 VUUR	CRY 22 VUU	136	9.525 ($\frac{3}{8}$)	34.925 (1 $\frac{3}{8}$)	20.638 (0.8125)	19.050 ($\frac{3}{4}$)		25.0 (0.984)	360 (14)	1.588 ($\frac{1}{16}$)	9.507	9.517	9.523	9.533	9.528	9.538	23 600	31 700	2 450	11 800
11.112 ($\frac{7}{16}$)	CRY 24 VR	CRY 24 V	CRY 24 VUUR	CRY 24 VUU	186	11.112 ($\frac{7}{16}$)	38.100 (1 $\frac{1}{2}$)	23.813 (0.9375)	22.225 ($\frac{7}{8}$)		28.8 (1.134)	500 (20)	1.588 ($\frac{1}{16}$)	11.095	11.105	11.110	11.120	11.115	11.125	28 200	40 100	3 410	15 400
	CRY 26 VR	CRY 26 V	CRY 26 VUUR	CRY 26 VUU	227	11.112 ($\frac{7}{16}$)	41.275 (1 $\frac{5}{8}$)	23.813 (0.9375)	22.225 ($\frac{7}{8}$)		28.8 (1.134)	500 (20)	1.588 ($\frac{1}{16}$)	11.095	11.105	11.110	11.120	11.115	11.125	28 200	40 100	3 820	16 700
12.700 ($\frac{1}{2}$)	CRY 28 VR	CRY 28 V	CRY 28 VUUR	CRY 28 VUU	290	12.700 ($\frac{1}{2}$)	44.450 (1 $\frac{3}{4}$)	26.988 (1.0625)	25.400 (1)		32.7 (1.287)	500 (20)	1.588 ($\frac{1}{16}$)	12.682	12.692	12.698	12.708	12.708	12.718	35 300	55 600	4 210	21 000
	CRY 30 VR	CRY 30 V	CRY 30 VUUR	CRY 30 VUU	363	12.700 ($\frac{1}{2}$)	47.625 (1 $\frac{7}{8}$)	26.988 (1.0625)	25.400 (1)		32.7 (1.287)	500 (20)	1.588 ($\frac{1}{16}$)	12.682	12.692	12.698	12.708	12.708	12.718	35 300	55 600	4 610	22 500
15.875 ($\frac{5}{8}$)	CRY 32 VR	CRY 32 V	CRY 32 VUUR	CRY 32 VUU	476	15.875 ($\frac{5}{8}$)	50.800 (2)	33.338 (1.3125)	31.750 (1 $\frac{1}{4}$)		36.0 (1.417)	600 (24)	1.588 ($\frac{1}{16}$)	15.857	15.867	15.873	15.883	15.883	15.893	45 700	80 600	5 690	30 800
	CRY 36 VR	CRY 36 V	CRY 36 VUUR	CRY 36 VUU	599	15.875 ($\frac{5}{8}$)	57.150 (2 $\frac{1}{4}$)	33.338 (1.3125)	31.750 (1 $\frac{1}{4}$)		36.0 (1.417)	600 (24)	1.588 ($\frac{1}{16}$)	15.857	15.867	15.873	15.883	15.883	15.893	45 700	80 600	6 640	34 700
19.050 ($\frac{3}{4}$)	CRY 40 VR	CRY 40 V	CRY 40 VUUR	CRY 40 VUU	816	19.050 ($\frac{3}{4}$)	63.500 (2 $\frac{1}{2}$)	39.688 (1.5625)	38.100 (1 $\frac{1}{2}$)		43.3 (1.705)	760 (30)	2.381 ($\frac{3}{32}$)	19.032	19.042	19.048	19.058	19.058	19.068	61 400	116 000	8 970	44 900
	CRY 44 VR	CRY 44 V	CRY 44 VUUR	CRY 44 VUU	1 020	19.050 ($\frac{3}{4}$)	69.850 (2 $\frac{3}{4}$)	39.688 (1.5625)	38.100 (1 $\frac{1}{2}$)		43.3 (1.705)	760 (30)	2.381 ($\frac{3}{32}$)	19.032	19.042	19.048	19.058	19.058	19.068	61 400	116 000	10 200	49 400
25.400 (1)	CRY 48 VR	CRY 48 V	CRY 48 VUUR	CRY 48 VUU	1 410	25.400 (1)	76.200 (3)	46.038 (1.8125)	44.450 (1 $\frac{3}{4}$)		54.0 (2.125)	760 (30)	2.381 ($\frac{3}{32}$)	25.377	25.390	25.397	25.410	25.408	25.420	77 600	172 000	11 400	64 300
	CRY 52 VR	CRY 52 V	CRY 52 VUUR	CRY 52 VUU	1 640	25.400 (1)	82.550 (3 $\frac{1}{4}$)	46.038 (1.8125)	44.450 (1 $\frac{3}{4}$)		54.0 (2.125)	760 (30)	2.381 ($\frac{3}{32}$)	25.377	25.390	25.397	25.410	25.408	25.420	77 600	172 000	12 700	69 600
28.575 (1 $\frac{1}{8}$)	CRY 56 VR	CRY 56 V	CRY 56 VUUR	CRY 56 VUU	2 250	28.575 (1 $\frac{1}{8}$)	88.900 (3 $\frac{1}{2}$)	52.388 (2.0625)	50.800 (2)		61.9 (2.437)	760 (30)	2.381 ($\frac{3}{32}$)	28.522	28.565	28.572	28.585	28.583	28.595	111 000	239 000	14 100	87 000
31.750 (1 $\frac{1}{4}$)	CRY 64 VR	CRY 64 V	CRY 64 VUUR	CRY 64 VUU	3 200	31.750 (1 $\frac{1}{4}$)	101.600 (4)	58.738 (2.3125)	57.150 (2 $\frac{1}{4}$)		71.0 (2.797)	760 (30)	2.381 ($\frac{3}{32}$)	31.727	31.740	31.747	31.760	31.758	31.770	142 000	317 000	16 800	113 000

Remark 1. The inner ring has an oil groove and an oil hole.
2. Provided with pre-packed grease.

Customized Products
Model Comparison Table
Miscellaneous Tables

Introduction of Customized Products 115
Model Comparison Table for Cam Followers 117
Model Comparison Table for Roller Followers 118
Miscellaneous Tables 119
Introduction of **IKO** Technical Service Site 127
Introduction of **IKO** Products 129

Introduction of Customized Products

IKO can also manufacture products with special specifications to suit the customer's requirements, in addition to the products listed in the catalog. This section introduces examples of customized products.

Special Outer Ring Products

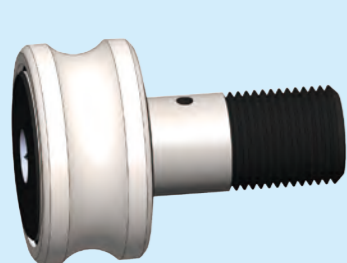

R-Groove Shaped Outer Ring

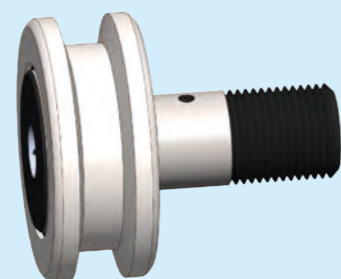

Pulley-Groove Shaped Outer Ring

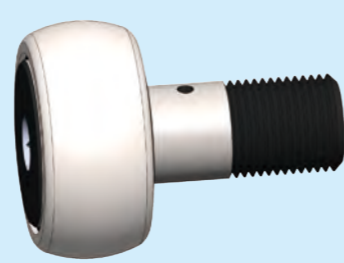

Spherical Shaped Outer Wheel

Overview / Applications

A special product with the grooved shape of the outer ring to match the surface of the mating cam guide. Use as a guide roller for the following circumstances.

- Steel wire or steel tube guides
- Rope guides for rope winders
- Belt tension guides

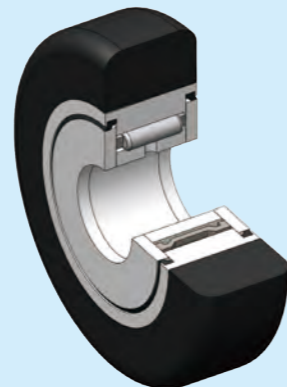
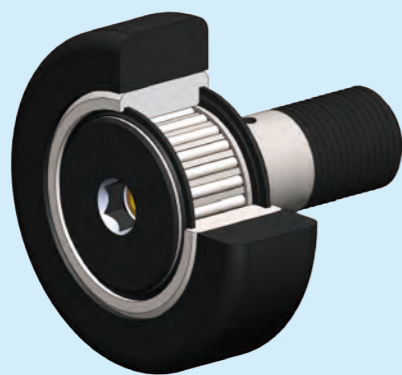

Urethane Rubber Attachments (CF, NAST)

Overview / Applications

The outer ring has a urethane rubber ring attached to allow for use in the following circumstances.

- For insulation purposes such as when metal contact with the mating cam guide is prohibited
- For the purpose of preventing noise generated from metal contact
- In places when lubricant cannot be used on the mating cam guide surface

Special Stud Products

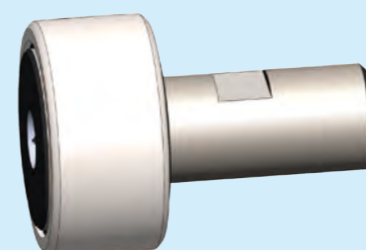

Stud with D Cut

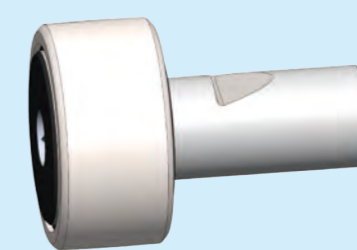

Stud with V Cut

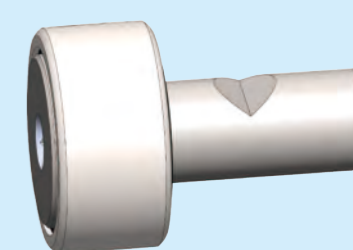

Stud with V Cut

Overview / Applications

With position fixable by fixing screws, it can be easily mounted and is often used as the gear cam guide for indexing machines.

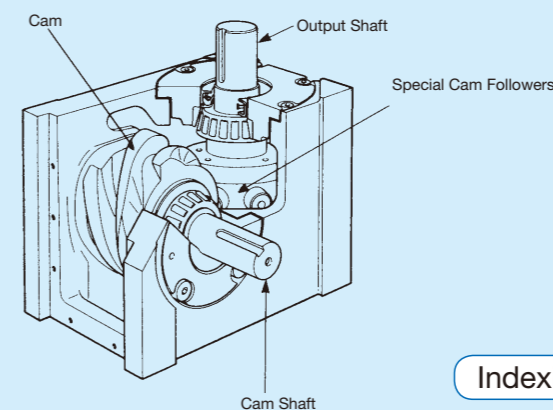

Indexing machine

Special Shaped Products

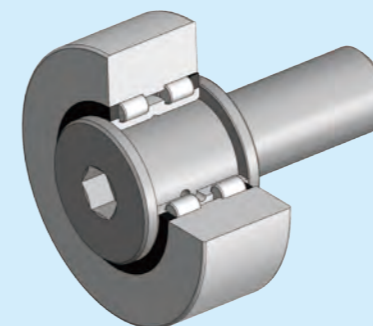

Roller Bearings Built In

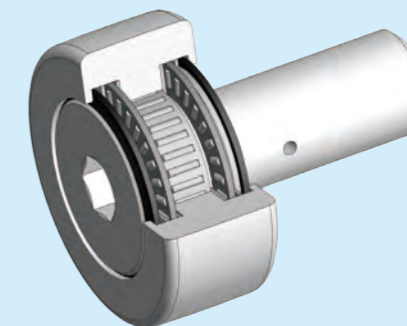

Thrust Bearings Built In

We also have a history of manufacturing many other special products. If you have any problems with special product applications, please contact **IKO**.

Model Comparison Table for Cam Followers

Model of bearing	IKO	Dimensions Page	JNS / THK	INA / SKF	Mc.GILL	KOYO TORRINGTON	SMITH
Miniature Type Cam Followers	CFS	31	CFS...A				
	CFS...V	31	CFS...VA				
	CFS...F	31	CFS...MA				
	CFS...FV	31	CFS...VMA				
Thrust Disk Type Miniature Cam Followers	CFS...W	33					
	CFS...WV	33					
	CFS...FW	33					
Standard Type Cam Followers	CF...BR	35	CF...RA	KR...SK	MFCR...B	KM...RHM	MCR...B
	CF...B	35	CF...A	KR...XSK	MFCR...BX	KM...HMM	MCR...CB
	CF...BUUR	35	CF...UURA	KR...PPSK	MFCR...SB	KM...UURHM	MCR...SB
	CF...BUU	35	CF...UUA	KR...PPXSK	MFCR...SBX	KM...UUHM	MCR...SCB
Standard Type Cam Followers (Full Complement Type)	CF...VBR	37	CF...VUURA	KRV...SK	MCF...BA	CM...RHM	MCRV...B
	CF...VB	37	CF...VA	KRV...XSK	MCF...BXA	CM...HM	MCRV...CB
	CF...VBUUR	37	CF...VUURA	KRV...PPSK	MCF...SB	CM...UURHM	MCRV...SB
	CF...VBUU	37	CF...VUUA	KRV...PPXSK	MCF...SBX	CM...UUHM	MCRV...SCB
Cam Follower G	CF...G	43					
Standard Type Cam Followers (Stainless Steel Made)	CF...FBR	35	CF...MRA				
	CF...FB	35	CF...MA				
	CF...FBUUR	35	CF...MUURA				
	CF...FBUU	35	CF...MUUA				
Double Hex Hole Cam Followers	CFKR	39	CF...AB	KR...X			
	CFKR...R	39	CF...RAB	KR			
	CFKR...UU	39	CF...UUAB	KR...PPX			
	CFKR...UUR	39	CF...UURAB	KR...PP			
Double Hex Hole Cam Followers (Full Complement Type)	CFKR...V	41	CF...VAB	KRV...X			
	CFKR...VR	41	CF...VRAB	KRV			
	CFKR...VUU	41	CF...VUUAB	KRV...PPX			
	CFKR...VUUR	41	CF...VUURAB	KRV...PP			
Thrust Disk Type Cam Followers	CF...WBR	45					
	CF...WBUUR	45					
	CF...FWBR	45					
	CF...FWBUUR	45					
C-Lube Cam Followers	CF...WBUUR/SG	47					
Solid Eccentric Stud Type Cam Followers	CFES...BR	49	CFH...RA				
	CFES...B	49	CFH...A				
	CFES...BUUR	49	CFH...UURA				
	CFES...BUU	49	CFH...UUA				
Eccentric Type Cam Followers	CFE...BR	51		KRE...SK	MCFRE...B		MCR...BE
	CFE...B	51		KRE...XSK	MCFRE...BX		MCR...CBE
	CFE...BUUR	51		KRE...PPSK	MCFRE...SB		MCR...SBE
	CFE...BUU	51		KRE...PPXSK	MCFRE...SBX		MCR...SCBE
Eccentric Type Cam Followers (Full Complement Type)	CFE...VBR	53		KRVE...SK	MCFE...B		MCRV...BE
	CFE...VB	53		KRVE...XSK	MCFE...BX		MCRV...CBE
	CFE...VBUUR	53		KRVE...PPSK	MCFE...SB		MCRV...SBE
	CFE...VBUU	53		KRVE...PPXSK	MCFE...SBX		MCRV...SCBE
Centralized Lubrication Type Cam Followers (With Screwdriver Slot)	CF-RU1	55	CFT...UUR				
	CF-FU1	55	CFT...UU				
Easy Mounting Type Cam Followers	CF-SFU...B	57	CF-SFU...				
Cylindrical Roller Cam Followers	NUCF...BR	59	NUCF...AB	NUKR	MCFD		NUKR...B

Remark **IKO** Cam Followers have a hexagon socket for easy mounting and an original lubrication mechanism that allows lubrication from the stud head.

Model Comparison Table for Inch Series Cam Followers

Model of bearing	IKO	Dimensions Page	JNS / THK	INA / SKF	Mc.GILL	KOYO TORRINGTON	SMITH	RBC
Inch Series Cam Followers (With Cage / With Hexagon Socket)	CR...BR	61		CFC...YSK				
	CR...B	61		CFC...SK				
	CR...BUUR	61		CFC...PPYSK				
	CR...BUU	61		CFC...PPSK				
Inch Series Cam Followers (With Cage / With Screwdriver Slot)	CR...R	63	CR...R	CFC...Y				
	CR	63	CR...	CFC				
	CR...UUR	63	CR...UUR	CFC...PPPY				
	CR...UU	63	CR...UU	CFC...PP				
Inch Series Cam Followers (Full Complement Type / With Hexagon Socket)	CR...VBR	65		CF...YSK	CCF...B	CRBC	CR...BC	CS...W
	CR...VB	65		CF...SK	CF...B	CRB	CR...B	S...W
	CR...VBUUR	65		CF...PPYSK	CCF...SB	CRSBC	CR...XBC	CS...LW
	CR...VBUU	65		CF...PPSK	CF...SB	CRSB	CR...XB	S...LW
Inch Series Cam Followers (Full Complement Type / With Screwdriver Slot)	CR...VR	67		CF...Y	CCF	CRC		CS
	CR...V	67		CF	CF	CR		S
	CR...VUUR	67		CF...PPY	CCF...S	CRSC		CS...L
	CR...VUU	67		CF...PP	CF...S	CRS		S...L
Inch Series Cam Followers (Full Complement Type / With Hexagon Socket)	CRH...VBR	69			CCFH...B		HR...BC	CH...W
	CRH...VB	69			CFH...B		HR...B	H...W
	CRH...VBUUR	69			CCFH...SB		HR...XBC	CH...LW
	CRH...VBUU	69			CFH...SB		HR...XB	H...LW
Inch Series Cam Followers (Full Complement Type / With Screwdriver Slot)	CRH...VR	71			CCFH...B		HR...BC	CH
	CRH...V	71			CFH...B		HR...B	H
	CRH...VUUR	71			CCFH...SB		HR...XBC	CH...L
	CRH...VUU	71			CFH...SB		HR...XB	H...L

Model Comparison Table for Roller Followers

Model of bearing	IKO	Dimensions Page	JNS / THK	INA / SKF	Mc.GILL	KOYO TORRINGTON	SMITH
Separable Roller Followers (Open Type / Without Inner Ring)	RNAST...R	85	RNAST...R	RSTO		RSTO...	
	RNAST	85	RNAST	RSTO...X		RSTO...DZ	
Separable Roller Followers (Open Type / With Inner Ring)	NAST...R	86	NAST...R	STO		STO...	
	NAST	86	NAST	STO...X		STO...DZ	
Separable Roller Followers (Shield Type / With Inner Ring)	NAST...ZZR	87	NAST...ZZR	NAST...2Z (SKF)		STO...ZZ	
	NAST...ZZ	87	NAST...ZZ	NAST...P2Z (SKF)		STO...ZZDZ	
Separable Roller Followers (Sealed Type / With Inner Ring)	NAST...ZZUUR	87	NAST...ZZUUR				
	NAST...ZZUU	87	NAST...ZZUU				
Non-separable Roller Followers	NART...R	89	NART...R	NATR	MCYRR	CXM...RM	
	NART...VR	89	NART...VR	NATV	MCYR	CYM...RM	
	NART...UUR	89	NART...UUR	NATR...PP	MCYRR...S	CXM...UURM	
	NART...VUUR	89	NART...UUVR	NATV...PP	MCYR...S	CYM...UURM	
Non-separable Roller Followers (Stainless Steel)	NART...FR	91	NART...MR				
	NART...FUUR	91	NART...MUUR				
C-Lube Roller Followers	NART...UUR/SG	93					
Cylindrical Roller Followers	NURT...R	95	NURT...R	NUTR	MYCRD		
	NURT	95	NURT...X		MYCRD...X		
Inch Series Non-separable Roller Followers	CRY...VR	97		RF...Y	CCYR		
	CRY...V	97		RF	CYR		
	CRY...VUUR	97		RF...PPY	CCYR...S		
	CRY...VUU	97		RF...PP	CYR...S		

Miscellaneous Tables

Unit Conversion Rate Table

Comparison table between SI units, CGS units and gravitational system of units

Item System of units	Length	Mass	Time	Acceleration	Force	Stress and pressure
SI units	m	kg	s	m/s ²	N	Pa
CGS units	cm	g	s	Gal	dyn	dyn/cm ²
Gravity units	m	kgf·s ² /m	s	m/s ²	kgf	kgf/m ²

Conversion into SI units

Item	Unit name	Symbol	SI conversion rate	SI unit name	Symbol
Angle	Degree	°	$\pi/180$	Radian	rad
	Minute	'	$\pi/10\ 800$		
	Second	"	$\pi/648\ 000$		
Length	Meter	m	1	Meter	m
	Micron	μ	10^{-6}		
	Angstrom	Å	10^{-10}		
	X ray unit		$\approx 1.002\ 08 \times 10^{-13}$		
	Nautical mile	n mile	1852		
Area	Square meter	m ²	1	Square meter	m ²
	Are	a	10^2		
	Hectare	ha	10^4		
Volume	Cubic meter	m ³	1	Cubic meter	m ³
	Liter	l, L	10^{-3}		
Mass	Kilogram	kg	1	Kilogram	kg
	Ton	t	10^3		
	Atomic mass unit	u	$\approx 1.660\ 57 \times 10^{-27}$		
Time	Second	s	1	Second	s
	Minute	min	60		
	Hour	h	3 600		
	Day	d	86 400		
Velocity	Meter per second	m/s	1	Meter per second	m/s
	Knot	kn	1 852/3 600		
Frequency and vibration	Cycle	s ⁻¹	1	Hertz	Hz
Rotation speed	Rotation per minute	rpm	1/60	Per second	s ⁻¹
Angular velocity	Radian per second	rad/s	1	Radian per second	rad/s
Acceleration	Meter per second squared	m/s ²	1	Meter per second squared	m/s ²
	G	G	9.806 65		
Force	Kilogram force	kgf	9.806 65	Newton	N
	Ton force	tf	9 806.65		
	Dyne	dyn	10^{-5}		
Moment of force	Kilogram force-meter	kgf·m	9.806 65	Newton-meter	N·m
Stress and pressure	Kilogram force per square meter	kgf/m ²	9.806 65	Pascal	Pa
	Kilogram force per square centimeter	kgf/cm ²	$9.806\ 65 \times 10^4$		
	Kilogram force per square millimeter	kgf/mm ²	$9.806\ 65 \times 10^6$		

Energy	Power	Temperature	Viscosity	Kinematic viscosity	Magnetic flux	Magnetic flux density	Magnetic field intensity
J	W	K	Pa·s	m ² /s	Wb	T	A/m
erg	erg/s	°C	P	St	Mx	Gs	Oe
kgf·m	kgf·m/s	°C	kgf·s/m ²	m ² /s	—	—	—

Item	Unit name	Symbol	SI conversion rate	SI unit name	Symbol
Pressure	Hydro-column meter	mH ₂ O	9 806.65	Pascal	Pa
	Mercury column millimeter	mmHg	101 325/760		
	Torr	Torr	101 325/760		
	Atmosphere	atm	101 325		
Energy	Bar	bar	10^5	Joule	J
	Erg	erg	10^{-7}		
	IT calorie	cal _{IT}	4.186 8		
	Kilogram force-meter	kgf·m	9.806 65		
	Kilowatt hour	kW·h	3.600×10^6		
Power and motivity	Horse power hour (French)	PS·h	$\approx 2.647\ 79 \times 10^6$	Watt	W
	Electron volt	eV	$\approx 1.602\ 19 \times 10^{-19}$		
	Watt	W	1		
Viscosity	Horse power (French)	PS	≈ 735.5	Pascal-second	Pa·s
	Kilogram force-meter per second	kgf·m/s	9.806 65		
	Poise	P	10^{-1}		
Kinematic viscosity	Centipoise	cP	10^{-3}	Square meter per second	m ² /s
	Kilogram force-second per square meter	kgf·s/m ²	9.806 65		
	Stokes	St	10^{-4}		
Temperature	Centistokes	cSt	10^{-6}	Kelvin	K
	degree	°C	+273.15		
Radioactivity	Curie	Ci	3.7×10^{10}	Becquerel	Bq
	Roentgen	R	2.58×10^{-4}		
Exposure dose	Absorbed dose	rad	10^{-2}	Coulomb per kilogram	C/kg
	Dose equivalent	rem	10^{-2}		
Magnetic flux	Gray	Gy		Weber	Wb
	Sievert	Sv			
Magnetic flux density	Maxwell	Mx	10^{-8}	Tesla	T
	Gamma	γ	10^{-9}		
Magnetic field intensity	Gauss	Gs	10^{-4}	Ampere per meter	A/m
	Oersted	Oe	$10^3/4\pi$		
Electric quantity	Coulomb	C	1	Coulomb	C
	Electric potential difference	V	1		
Electrostatic capacity	Volt	V	1	Farad	F
	Farad	F	1		
(Electric) resistance	Ohm	Ω	1	Ohm	Ω
	(Electric) conductance	S	1		
Inductance	Siemens	S	1	Henry	H
	Henry	H	1		
Current	Ampere	A	1	Ampere	A

● Hardness Conversion Table (Reference)

Rockwell C scale hardness Load 1471 N HRC	Vickers hardness HV	Brinell hardness		Rockwell hardness		Shore hardness HS
		Standard ball	Tungsten carbide ball	A scale Load 588.4 N Diamond circular cone	B scale Load 980.7 N Diameter 1/16 inch ball	
68	940	—	—	85.6	—	97
67	900	—	—	85.0	—	95
66	865	—	—	84.5	—	92
65	832	—	(739)	83.9	—	91
64	800	—	(722)	83.4	—	88
63	772	—	(705)	82.8	—	87
62	746	—	(688)	82.3	—	85
61	720	—	(670)	81.8	—	83
60	697	—	(654)	81.2	—	81
59	674	—	(634)	80.7	—	80
58	653	—	615	80.1	—	78
57	633	—	595	79.6	—	76
56	613	—	577	79.0	—	75
55	595	—	560	78.5	—	74
54	577	—	543	78.0	—	72
53	560	—	525	77.4	—	71
52	544	(500)	512	76.8	—	69
51	528	(487)	496	76.3	—	68
50	513	(475)	481	75.9	—	67
49	498	(464)	469	75.2	—	66
48	484	451	455	74.7	—	64
47	471	442	443	74.1	—	63
46	458	432	432	73.6	—	62
45	446	421	421	73.1	—	60
44	434	409	409	72.5	—	58
43	423	400	400	72.0	—	57
42	412	390	390	71.5	—	56
41	402	381	381	70.9	—	55
40	392	371	371	70.4	—	54
39	382	362	362	69.9	—	52

Rockwell C scale hardness Load 1471 N HRC	Vickers hardness HV	Brinell hardness		Rockwell hardness		Shore hardness HS
		Standard ball	Tungsten carbide ball	A scale Load 588.4 N Diamond circular cone	B scale Load 980.7 N Diameter 1/16 inch ball	
38	372	353	353	69.4	—	51
37	363	344	344	68.9	—	50
36	354	336	336	68.4	(109.0)	49
35	345	327	327	67.9	(108.5)	48
34	336	319	319	67.4	(108.0)	47
33	327	311	311	66.8	(107.5)	46
32	318	301	301	66.3	(107.0)	44
31	310	294	294	65.8	(106.0)	43
30	302	286	286	65.3	(105.5)	42
29	294	279	279	64.7	(104.5)	41
28	286	271	271	64.3	(104.0)	41
27	279	264	264	63.8	(103.0)	40
26	272	258	258	63.3	(102.5)	38
25	266	253	253	62.8	(101.5)	38
24	260	247	247	62.4	(101.0)	37
23	254	243	243	62.0	100.0	36
22	248	237	237	61.5	99.0	35
21	243	231	231	61.0	98.5	35
20	238	226	226	60.5	97.8	34
(18)	230	219	219	—	96.7	33
(16)	222	212	212	—	95.5	32
(14)	213	203	203	—	93.9	31
(12)	204	194	194	—	92.3	29
(10)	196	187	187	—	90.7	28
(8)	188	179	179	—	89.5	27
(6)	180	171	171	—	87.1	26
(4)	173	165	165	—	85.5	25
(2)	166	158	158	—	83.5	24
(0)	160	152	152	—	81.7	24

Miscellaneous Tables

Shaft Diameter Tolerance

Classification of diameter mm		b12		c12		d6		e6		e12		f5		f6		g5	
Over	Incl.	High	Low	High	Low	High	Low	High	Low	High	Low	High	Low	High	Low	High	Low
—	3	-140	-240	-60	-160	-20	-26	-14	-20	-14	-114	-6	-10	-6	-12	-2	-6
3	6	-140	-260	-70	-190	-30	-38	-20	-28	-20	-140	-10	-15	-10	-18	-4	-9
6	10	-150	-300	-80	-230	-40	-49	-25	-34	-25	-175	-13	-19	-13	-22	-5	-11
10	18	-150	-330	-95	-275	-50	-61	-32	-43	-32	-212	-16	-24	-16	-27	-6	-14
18	30	-160	-370	-110	-320	-65	-78	-40	-53	-40	-250	-20	-29	-20	-33	-7	-16
30	40	-170	-420	-120	-370	-80	-96	-50	-66	-50	-300	-25	-36	-25	-41	-9	-20
40	50	-180	-430	-130	-380	-80	-96	-50	-66	-50	-300	-25	-36	-25	-41	-9	-20
50	65	-190	-490	-140	-440	-100	-119	-60	-79	-60	-360	-30	-43	-30	-49	-10	-23
65	80	-200	-500	-150	-450	-100	-119	-60	-79	-60	-360	-30	-43	-30	-49	-10	-23
80	100	-220	-570	-170	-520	-120	-142	-72	-94	-72	-422	-36	-51	-36	-58	-12	-27
100	120	-240	-590	-180	-530	-120	-142	-72	-94	-72	-422	-36	-51	-36	-58	-12	-27
120	140	-260	-660	-200	-600	-145	-170	-85	-110	-85	-485	-43	-61	-43	-68	-14	-32
140	160	-280	-680	-210	-610	-145	-170	-85	-110	-85	-485	-43	-61	-43	-68	-14	-32
160	180	-310	-710	-230	-630	-145	-170	-85	-110	-85	-485	-43	-61	-43	-68	-14	-32
180	200	-340	-800	-240	-700	-170	-199	-100	-129	-100	-560	-50	-70	-50	-79	-15	-35
200	225	-380	-840	-260	-720	-170	-199	-100	-129	-100	-560	-50	-70	-50	-79	-15	-35
225	250	-420	-880	-280	-740	-170	-199	-100	-129	-100	-560	-50	-70	-50	-79	-15	-35
250	280	-480	-1000	-300	-820	-190	-222	-110	-142	-110	-630	-56	-79	-56	-88	-17	-40
280	315	-540	-1060	-330	-850	-190	-222	-110	-142	-110	-630	-56	-79	-56	-88	-17	-40
315	355	-600	-1170	-360	-930	-210	-246	-125	-161	-125	-695	-62	-87	-62	-98	-18	-43
355	400	-680	-1250	-400	-970	-210	-246	-125	-161	-125	-695	-62	-87	-62	-98	-18	-43
400	450	-760	-1390	-440	-1070	-230	-270	-135	-175	-135	-765	-68	-95	-68	-108	-20	-47
450	500	-840	-1470	-480	-1110	-230	-270	-135	-175	-135	-765	-68	-95	-68	-108	-20	-47

unit: μm

Classification of diameter mm		g6		h5		h6		h7		h8		h9		h10		h11		Classification of diameter mm	
Over	Incl.	High	Low	High	Low	High	Low	High	Low	High	Low	High	Low	High	Low	High	Low	Over	Incl.
—	3	-2	-8	0	-4	0	-6	0	-10	0	-14	0	-25	0	-40	0	-60	—	3
3	6	-4	-12	0	-5	0	-8	0	-12	0	-18	0	-30	0	-48	0	-75	3	6
6	10	-5	-14	0	-6	0	-9	0	-15	0	-22	0	-36	0	-58	0	-90	6	10
10	18	-6	-17	0	-8	0	-11	0	-18	0	-27	0	-43	0	-70	0	-110	10	18
18	30	-7	-20	0	-9	0	-13	0	-21	0	-33	0	-52	0	-84	0	-130	18	30
30	40	-9	-25	0	-11	0	-16	0	-25	0	-39	0	-62	0	-100	0	-160	30	40
40	50	-9	-25	0	-11	0	-16	0	-25	0	-39	0	-62	0	-100	0	-160	40	50
50	65	-10	-29	0	-13	0	-19	0	-30	0	-46	0	-74	0	-120	0	-190	50	65
65	80	-10	-29	0	-13	0	-19	0	-30	0	-46	0	-74	0	-120	0	-190	65	80
80	100	-12	-34	0	-15	0	-22	0	-35	0	-54	0	-87	0	-140	0	-220	80	100
100	120	-12	-34	0	-15	0	-22	0	-35	0	-54	0	-87	0	-140	0	-220	100	120
120	140	-14	-39	0	-18	0	-25	0	-40	0	-63	0	-100	0	-160	0	-250	120	140
140	160	-14	-39	0	-18	0	-25	0	-40	0	-63	0	-100	0	-160	0	-250	140	160
160	180	-14	-39	0	-18	0	-25	0	-40	0	-63	0	-100	0	-160	0	-250	160	180
180	200	-15	-44	0	-20	0	-29	0	-46	0	-72	0	-115	0	-185	0	-290	180	200
200	225	-15	-44	0	-20	0	-29	0	-46	0	-72	0	-115	0	-185	0	-290	200	225
225	250	-15	-44	0	-20	0	-29	0	-46	0	-72	0	-115	0	-185	0	-290	225	250
250	280	-17	-49	0	-23	0	-32	0	-52	0	-81	0	-130	0	-210	0	-320	250	280
280	315	-17	-49	0	-23	0	-32	0	-52	0	-81	0	-130	0	-210	0	-320	280	315
315	355	-18	-54	0	-25	0	-36	0	-57	0	-89	0	-140	0	-230	0	-360	315	355
355	400	-18	-54	0	-25	0	-36	0	-57	0	-89	0	-140	0	-230	0	-360	355	400
400	450	-20	-60	0	-27	0	-40	0	-63	0	-97	0	-155	0	-250	0	-400	400	450
450	500	-20	-60	0	-27	0	-40	0	-63	0	-97	0	-155	0	-250	0	-400	450	500

Classification of diameter mm		h12		js5		j5		js6		j6		j7		k5		k6	
Over	Incl.	High	Low	High	Low	High	Low	High	Low	High	Low	High	Low	High	Low	High	Low
—	3	0	-100	+2	-2	+2	-2	+3	-3	+4	-2	+6	-4	+4	0	+6	0
3	6	0	-120	+2.5	-2.5	+3	-2	+4	-4	+6	-2	+8	-4	+6	+1	+9	+1
6	10	0	-150	+3	-3	+4	-2	+4.5	-4.5	+7	-2	+10	-5	+7	+1	+10	+1
10	18	0	-180	+4	-4	+5	-3	+5.5	-5.5	+8	-3	+12	-6	+9	+1	+12	+1
18	30	0	-210	+4.5	-4.5	+5	-4	+6.5	-6.5	+9	-4	+13	-8	+11	+2	+15	+2
30	40	0	-250	+5.5	-5.5	+6	-5	+8	-8	+11	-5	+15	-10	+13	+2	+18	+2
40	50	0	-250	+5.5	-5.5	+6	-5	+8	-8	+11	-5	+15	-10	+13	+2	+18	+2
50	65	0	-300	+6.5	-6.5	+6	-7	+9.5	-9.5	+12	-7	+18	-12	+15	+2	+21	+2
65	80	0	-300	+6.5	-6.5	+6	-7	+9.5	-9.5	+12	-7	+18	-12	+15	+2	+21	+2
80	100	0	-350	+7.5	-7.5	+6	-9	+11	-11	+13	-9	+20	-15	+18	+3	+25	+3
100	120	0	-350	+7.5	-7.5	+6	-9	+11	-11	+13	-9	+20	-15	+18	+3	+25	+3
120	140	0	-400	+9	-9	+7	-11	+12.5	-12.5	+14	-11	+22	-18	+21	+3	+28	+3
140	160	0	-400	+9	-9	+7	-11	+12.5	-12.5	+14	-11	+22	-18	+21	+3	+28	+3
160	180	0	-400	+9	-9	+7	-11	+12.5	-12.5	+14	-11	+22	-18	+21	+3	+28	+3
180	200	0	-460	+10	-10	+7	-13	+14.5	-14.5	+16	-13	+25	-21	+24	+4	+33	+4
200	225	0	-460	+10	-10	+7	-13	+14.5	-14.5	+16	-13	+25	-21	+24	+4	+33	+4
225	250	0	-460	+10	-10	+7	-13	+14.5	-14.5	+16	-13	+25	-21	+24	+4	+33	+4
250	280	0	-520	+11.5	-11.5	+7	-16	+16	-16	+16	-16	+26	-26	+27	+4	+36	+4
280	315	0	-520	+11.5	-11.5	+7	-16	+16	-16	+16	-16	+26	-26	+27	+4	+36	+4
315	355	0	-570	+12.5	-12.5	+7	-18	+18	-18	+18	-18	+29	-28	+29	+4	+40	+4
355	400	0	-570	+12.5	-12.5	+7	-18	+18	-18	+18	-18	+29	-28	+29	+4	+40	+4
400	450	0	-630	+13.5	-13.5	+7	-20	+20	-20	+20	-20	+31	-32	+32	+5	+45	+5
450	500	0	-630	+13.5	-13.5	+7	-20	+20	-20	+20	-20	+31	-32	+32	+5	+45	+5

unit: μm

Classification of diameter mm		m5		m6		n5		n6		p6		Classification of diameter mm	
Over	Incl.	High	Low	High	Low	High	Low	High	Low	High	Low	Over	Incl.
—	3	+6	+2	+8	+2	+8	+4	+10	+4	+12	+6	—	3
3	6	+9	+4	+12	+4	+13	+8	+16	+8	+20	+12	3	6
6	10	+12	+6	+15	+6	+16	+10	+19	+10	+24	+15	6	10
10	18	+15	+7	+18	+7	+20	+12	+23	+12	+29	+18	10	18
18	30	+17	+8	+21	+8	+24	+15	+28	+15	+35	+22	18	30
30	40	+20	+9	+25	+9	+28	+17	+33	+17	+42	+26	30	40
40	50	+20	+9	+25	+9	+28	+17	+33	+17	+42	+26	40	50
50	65	+24	+11	+30	+11	+33	+20	+39	+20	+51	+32	50	65
65	80	+24	+11	+30	+11	+33	+20	+39	+20	+51	+32	65	80
80	100	+28	+13	+35	+13	+38	+23	+45	+23	+59	+37	80	100
100	120	+28	+13	+35	+13	+38	+23	+45	+23	+59	+37	100	120
120	140	+33	+15	+40	+15	+45	+27	+52	+27	+68	+43	120	140
140	160	+33	+15	+40	+15	+45	+27	+52	+27	+68	+43	140	160
160	180	+33	+15	+40	+15	+45	+27	+52	+27	+68	+43	160	180
180	200	+37	+17	+46	+17	+51	+31	+60	+31	+79	+50	180	200
200	225	+37	+17	+46	+17	+51	+31	+60	+31	+79	+50	200	225
225	250												

Miscellaneous Tables

Housing Bore Diameter Tolerance

Classification of diameter mm		B12		E7		E11		E12		F6		F7		G6		G7	
Over	Incl.	High	Low	High	Low	High	Low	High	Low	High	Low	High	Low	High	Low	High	Low
—	3	+ 240	+140	+ 24	+ 14	+ 74	+ 14	+114	+ 14	+ 12	+ 6	+ 16	+ 6	+ 8	+ 2	+12	+ 2
3	6	+ 260	+140	+ 32	+ 20	+ 95	+ 20	+140	+ 20	+ 18	+10	+ 22	+10	+12	+ 4	+16	+ 4
6	10	+ 300	+150	+ 40	+ 25	+115	+ 25	+175	+ 25	+ 22	+13	+ 28	+13	+14	+ 5	+20	+ 5
10	18	+ 330	+150	+ 50	+ 32	+142	+ 32	+212	+ 32	+ 27	+16	+ 34	+16	+17	+ 6	+24	+ 6
18	30	+ 370	+160	+ 61	+ 40	+170	+ 40	+250	+ 40	+ 33	+20	+ 41	+20	+20	+ 7	+28	+ 7
30	40	+ 420	+170	+ 75	+ 50	+210	+ 50	+300	+ 50	+ 41	+25	+ 50	+25	+25	+ 9	+34	+ 9
40	50	+ 430	+180														
50	65	+ 490	+190	+ 90	+ 60	+250	+ 60	+360	+ 60	+ 49	+30	+ 60	+30	+29	+10	+40	+10
65	80	+ 500	+200														
80	100	+ 570	+220	+107	+ 72	+292	+ 72	+422	+ 72	+ 58	+36	+ 71	+36	+34	+12	+47	+12
100	120	+ 590	+240														
120	140	+ 660	+260														
140	160	+ 680	+280	+125	+ 85	+335	+ 85	+485	+ 85	+ 68	+43	+ 83	+43	+39	+14	+54	+14
160	180	+ 710	+310														
180	200	+ 800	+340														
200	225	+ 840	+380	+146	+100	+390	+100	+560	+100	+ 79	+50	+ 96	+50	+44	+15	+61	+15
225	250	+ 880	+420														
250	280	+1000	+480	+162	+110	+430	+110	+630	+110	+ 88	+56	+108	+56	+49	+17	+69	+17
280	315	+1060	+540														
315	355	+1170	+600	+182	+125	+485	+125	+695	+125	+ 98	+62	+119	+62	+54	+18	+75	+18
355	400	+1250	+680														
400	450	+1390	+760	+198	+135	+535	+135	+765	+135	+108	+68	+131	+68	+60	+20	+83	+20
450	500	+1470	+840														

Classification of diameter mm		JS7		J7		K5		K6		K7		M6		M7		N6	
Over	Incl.	High	Low	High	Low	High	Low	High	Low	High	Low	High	Low	High	Low	High	Low
—	3	+ 5	- 5	+ 4	- 6	0	- 4	0	- 6	0	-10	- 2	- 8	-2	-12	- 4	-10
3	6	+ 6	- 6	+ 6	- 6	0	- 5	+2	- 6	+ 3	- 9	- 1	- 9	0	-12	- 5	-13
6	10	+ 7	- 7	+ 8	- 7	+1	- 5	+2	- 7	+ 5	-10	- 3	-12	0	-15	- 7	-16
10	18	+ 9	- 9	+10	- 8	+2	- 6	+2	- 9	+ 6	-12	- 4	-15	0	-18	- 9	-20
18	30	+10	-10	+12	- 9	+1	- 8	+2	-11	+ 6	-15	- 4	-17	0	-21	-11	-24
30	40	+12	-12	+14	-11	+2	- 9	+3	-13	+ 7	-18	- 4	-20	0	-25	-12	-28
40	50																
50	65	+15	-15	+18	-12	+3	-10	+4	-15	+ 9	-21	- 5	-24	0	-30	-14	-33
65	80																
80	100	+17	-17	+22	-13	+2	-13	+4	-18	+10	-25	- 6	-28	0	-35	-16	-38
100	120																
120	140	+20	-20	+26	-14	+3	-15	+4	-21	+12	-28	- 8	-33	0	-40	-20	-45
140	160																
160	180																
180	200	+23	-23	+30	-16	+2	-18	+5	-24	+13	-33	- 8	-37	0	-46	-22	-51
200	225																
225	250																
250	280	+26	-26	+36	-16	+3	-20	+5	-27	+16	-36	- 9	-41	0	-52	-25	-57
280	315																
315	355	+28	-28	+39	-18	+3	-22	+7	-29	+17	-40	-10	-46	0	-57	-26	-62
355	400																
400	450	+31	-31	+43	-20	+2	-25	+8	-32	+18	-45	-10	-50	0	-63	-27	-67
450	500																

unit: μm

Classification of diameter mm		H6		H7		H8		H9		H10		H11		JS6		J6	
Over	Incl.	High	Low	High	Low	High	Low	High	Low	High	Low	High	Low	High	Low	High	Low
—	3	+ 6	0	+10	0	+14	0	+ 25	0	+ 40	0	+ 60	0	+ 3	- 3	+ 2	-4
3	6	+ 8	0	+12	0	+18	0	+ 30	0	+ 48	0	+ 75	0	+ 4	- 4	+ 5	-3
6	10	+ 9	0	+15	0	+22	0	+ 36	0	+ 58	0	+ 90	0	+ 4.5	- 4.5	+ 5	-4
10	18	+11	0	+18	0	+27	0	+ 43	0	+ 70	0	+110	0	+ 5.5	- 5.5	+ 6	-5
18	30	+13	0	+21	0	+33	0	+ 52	0	+ 84	0	+130	0	+ 6.5	- 6.5	+ 8	-5
30	40	+16	0	+25	0	+39	0	+ 62	0	+100	0	+160	0	+ 8	- 8	+10	-6
40	50																
50	65	+19	0	+30	0	+46	0	+ 74	0	+120	0	+190	0	+ 9.5	- 9.5	+13	-6
65	80																
80	100	+22	0	+35	0	+54	0	+ 87	0	+140	0	+220	0	+11	-11	+16	-6
100	120																
120	140	+25	0	+40	0	+63	0	+100	0	+160	0	+250	0	+12.5	-12.5	+18	-7
140	160																
160	180																
180	200	+29	0	+46	0	+72	0	+115	0	+185	0	+290	0	+14.5	-14.5	+22	-7
200	225																
225	250																
250	280	+32	0	+52	0	+81	0	+130	0	+210	0	+320	0	+16	-16	+25	-7
280	315																
315	355	+36	0	+57	0	+89	0	+140	0	+230	0	+360	0	+18	-18	+29	-7
355	400																
400	450	+40	0	+63	0	+97	0	+155	0	+250	0	+400	0	+20	-20	+33	-7
450	500																

Classification of diameter mm		N7		P6		P7		R7		S7	
Over	Incl.	High	Low	High	Low	High	Low	High	Low	High	Low
—	3	- 4	-14	- 6	-12	- 6	- 16	- 10	- 20	- 14	- 24
3	6	- 4	-16	- 9	-17	- 8	- 20	- 11	- 23	- 15	- 27
6	10	- 4	-19	-12	-21	- 9	- 24	- 13	- 28	- 17	- 32
10	18	- 5	-23	-15	-26	-11	- 29	- 16	- 34	- 21	- 39
18	30	- 7	-28	-18	-31	-14	- 35	- 20	- 41	- 27	- 48
30	40	- 8	-33	-21	-37	-17	- 42	- 25	- 50	- 34	- 59
40	50										
50	65	- 9	-39	-26	-45	-21	- 51	- 30	- 60	- 42	- 72
65	80										
80	100	-10	-45	-30	-52	-24	- 59	- 38	- 73	- 58	- 93
100	120										
120	140	-12	-52	-36	-61	-28	- 68	- 48	- 88	- 77	-117
140	160										
160	180										
180	200	-14	-60	-41	-70	-33	- 79	- 60	-106	-105	-151
200	225										
225	250										
250	280	-14	-66	-47	-79	-36	- 88	- 74	-126	-138	-190
280	315										
315	355	-16	-73	-51	-87	-41	- 98	- 87	-144	-169	-226
355	400										
400	450	-17	-80	-55	-95	-45	-108	-103	-166	-209	-272
450	500										

unit: μm

Introduction of IKO Technical Service Site

"IKO Technical Service Site" can be accessed from our home page IKO. The site also distributes various tools, etc., to select Linear Ways/Linear Roller Ways, and please utilize the site for the assistance to select products. Additionally the site also provides CAD data and product catalog of needle series, linear motion rolling guide series and mechatronics series for you to download. Please consider to use for enhancing your design efficiency.

<http://www.ikont.co.jp/eg/>

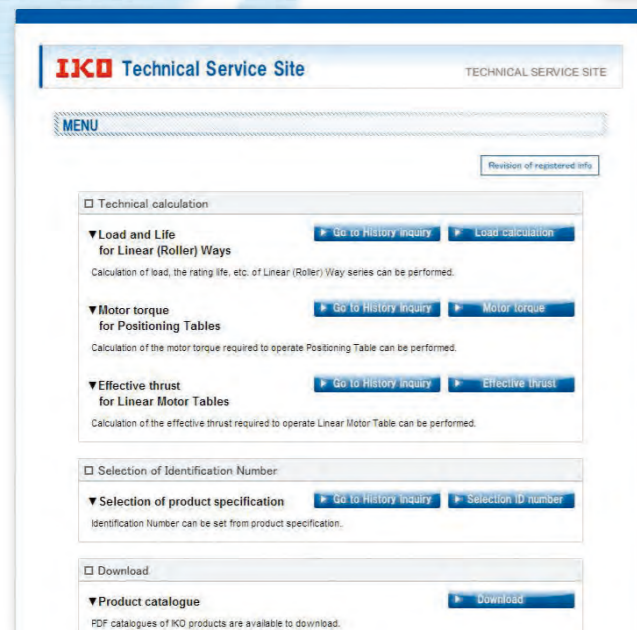
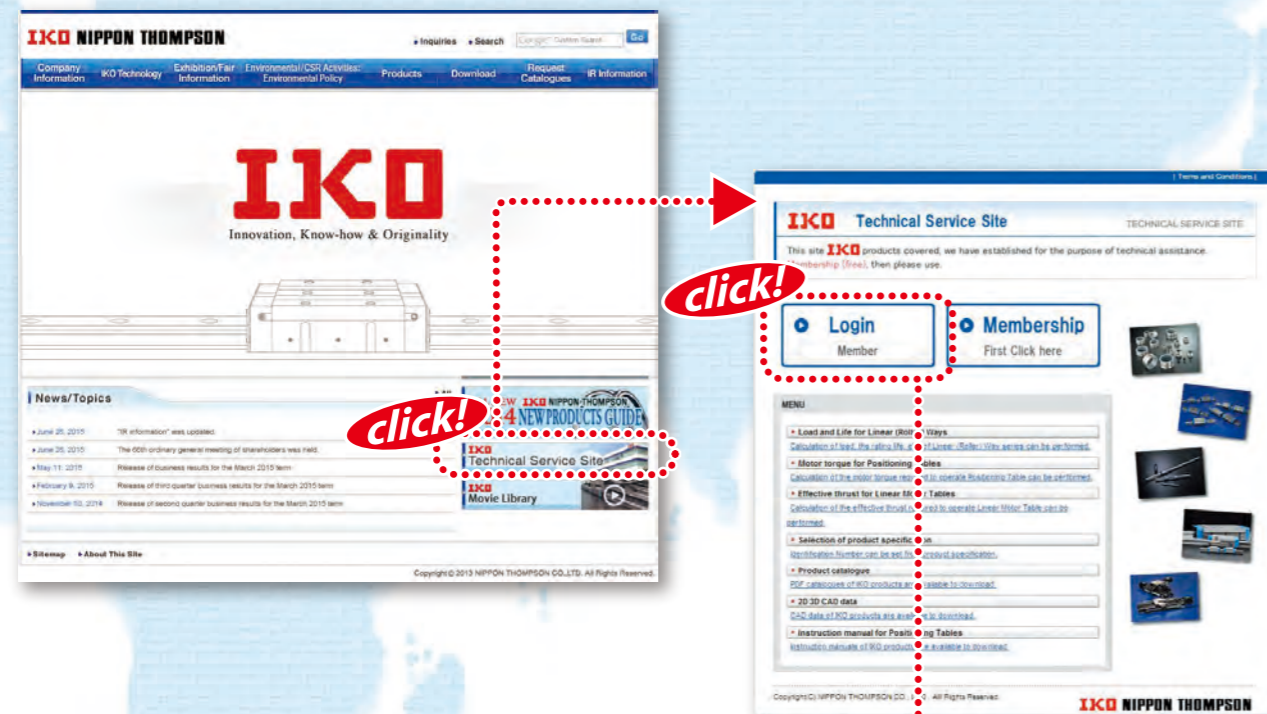

1. Technical calculations

For Linear Way/Linear Roller Way load and life calculation, you can obtain the calculated load and the rating life by entering the operating conditions. Also you can derive the motor torque required for operation and the effective thrust force during operation in the sections of motor torque calculation and calculation of effective thrust force of linear motor tables respectively, and output the calculation results in PDF format, as well as save the histories.

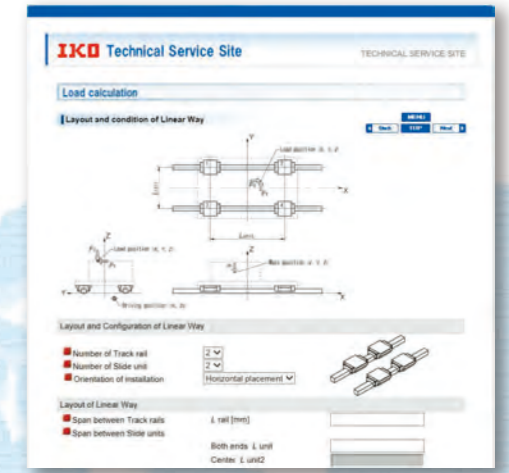

2. Selection of Identification Number

By selecting such specification as model code, dimensions, part code, material code, preload symbol, classification symbol, interchangeable code and supplemental code of Linear Ways/Linear Roller Ways, you can easily specify the identification number used for ordering.

Also you can browse the CAD data of the selected products, calculate the load, and output the selection results in PDF format, as well as save the histories.



3. Downloading CAD data

2-dimensional CAD data (DXF file)

There are two types of figures, brief figure and detailed figure. The brief figure shows only the external view lines, and the detailed figure shows the detailed lines. The drawing consists of three drawings: front view, side view and plain view. The scale shows only the original size (1:1), and it does not show dimension lines.

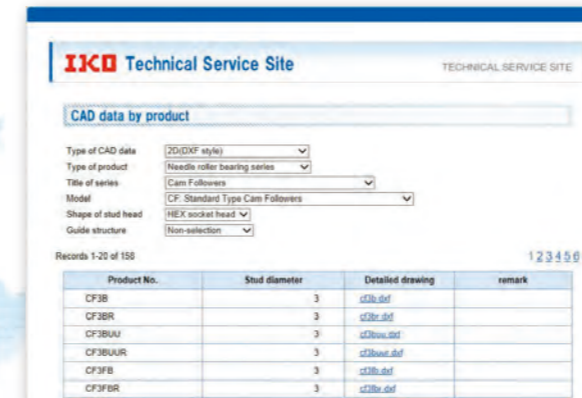

3-dimensional CAD data

It is linked to the mechanical parts CAD library "PART community". Entering the rail dimension and option contents to the detail, you can view the 2D/3D CAD data suitable for the specification for free of charge.



4. Downloading Catalog and Operation Manual

You can download product catalogs of needle series, linear motion rolling guide series and mechatronics series, operation manuals of precision positioning tables and various electrical components in PDF format, as well as support software for precision positioning tables. If you would like a copy of our catalog, please visit the IKO official website and apply for the catalog, or contact our regional office or sales office nearby.

Oil Minimum

IKO Gentle to The Earth

Nippon Thompson Co., Ltd. is working to develop global environment-friendly products.

It is committed to developing products that make its customers' machinery and equipment more reliable, thereby contributing to preserving the global environment.

This development stance manifests well in the keyword "Oil Minimum."

Our pursuit of Oil Minimum has led to the creation of
IKO's proprietary family of lubricating parts as "C-Lube."

IKO Products Underpin Sustain Technology Leaps

Nippon Thompson Co., Ltd. was the first Japanese manufacturer to develop needle bearings on its own and has since expanded into the arena of linear motion rolling guides (Linear Motion Series and Mechatro Series) on the support of its advanced expertise. The company now offers a vast assortment of ingenious products, including the world's first C-Lube maintenance-free series, to address increasingly diversified customer needs and thus sustain technology leaps.

C-Lube Maintenance-Free Series Products Evolving from the "Oil Minimum" Concept

We have developed lubricating parts impregnated with a large amount of lubricant as C-Lube Series to save the customer's oiling management workload and built them into bearings and linear motion rolling guides. The C-Lube Series not only keeps products maintenance-free for long by giving them an optimal and minimal amount of a lubricant for an extended period of time but also contributes greatly to preserving the global environment.



- **IKO** Linear Motion Rolling Guides are manufactured through a control system that alleviates their impact on the global environment to meet the quality requirements of ISO 14001 in compliance with the quality requirements level of ISO 9001 for quality improvement.
- The standard products listed in this catalog comply with the specifications of the six hazardous materials mentioned cited in the European RoHS Directive.