

**sedis** 

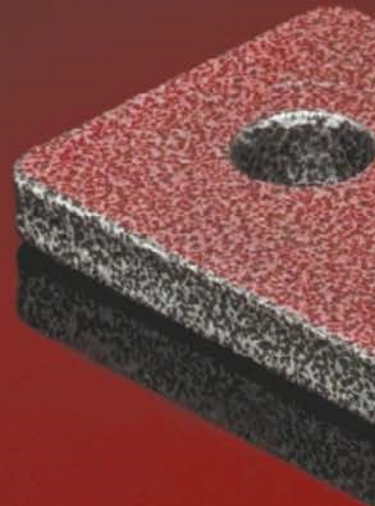

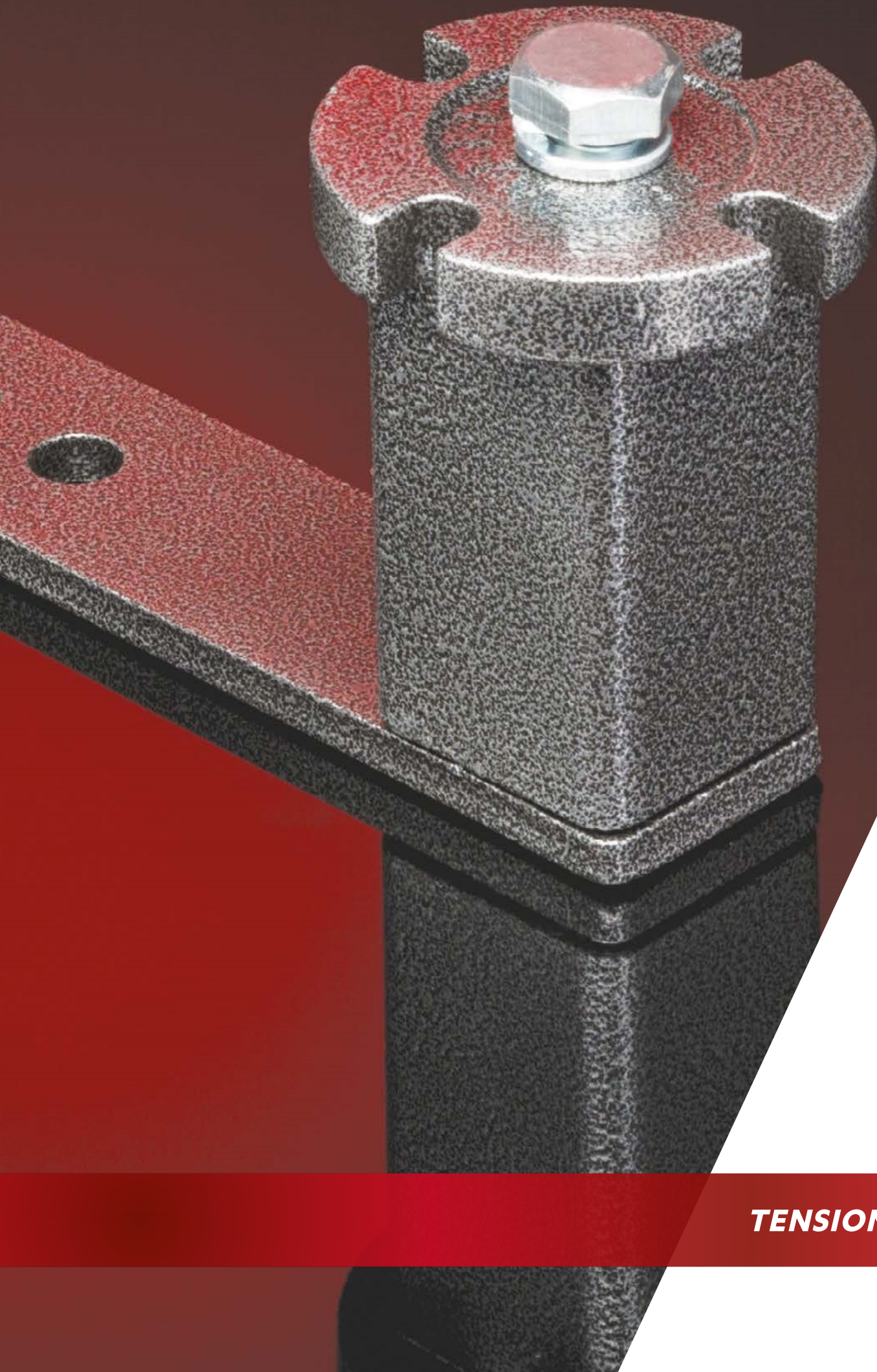

**TENSIONERS**



## ELASTIC CHAIN TENSIONERS - TYPE BT

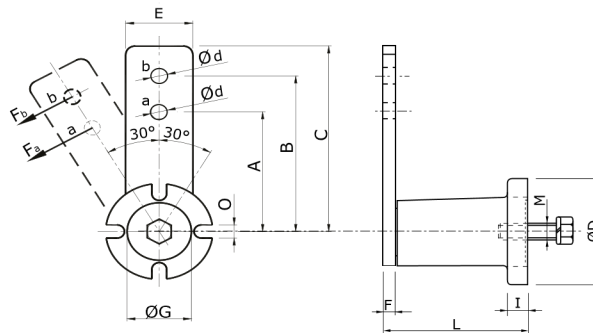

Reference	A	B	C	ØD	Ød	E	F	ØG	I	L	M	O	Fa pos. a [N]	Fb pos. b [N]	Kg
BT 11	60	80	90	40	8,5	25	5	20	6	50	M6	7	0-113	0-85	0,28
BT 15	80	100	112,5	50	10,5	30	5	30	8	62	M8	9	0-170	0-136	0,48
BT 18	80	100	115	60	10,5	35	6	35	10	76	M10	9	0-425	0-340	0,73
BT 27	100	130	155	80	12,5	50	8	48	15	105	M12	11	0-1027	0-790	2,00
BT 38	140	175	205	100	20,5	65	10	62	15	136	M16	13	0-2000	0-1600	4,20
BT 45	180	225	260	120	20,5	80	12	80	18	196	M20	13	0-3190	0-2550	7,00
BT 50	200	250	290	130	20,5	90	20	78	20	210	M24	17	0-4950	0-3950	9,60

Elastic tensioner arm type BT are made in epoxy coated cast-iron. they are also available in galvanized, nickel plated or stainless steel (From BT11 to BT38 : consult us for other dimensions).

Rotation angle +/- 30° - Operating temperature from - 40°C to + 80°C

Fa: Force made by the tensioner with the kit positioned in the a hole

Fb: Force made by the tensioner with the kit positioned in the b hole

## ELASTIC CHAIN TENSIONERS - TYPE BTF

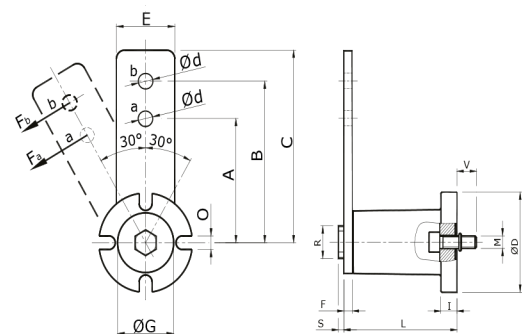
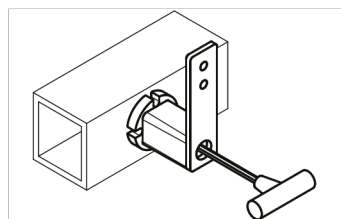

Reference	A	B	C	ØD	Ød	E	F	ØG	I	L	M	O	ØR	S	V	Fa pos. a [N]	Fb pos. b [N]	Kg
BTF 11	60	80	90	40	8,5	25	5	20	6	50	M5	7	14	3,5	10	0-113	0-85	0,25
BTF 15	80	100	112,5	50	10,5	30	5	30	8	62	M6	9	20	5	14	0-170	0-136	0,45
BTF 18	80	100	115	60	10,5	35	6	35	10	76	M8	9	20	5	19	0-425	0-340	0,69
BTF 27	100	130	155	80	12,5	50	8	48	15	105	M10	11	26	5	18	0-1027	0-790	1,90
BTF 38	140	175	205	100	20,5	65	10	62	15	136	M12	13	35	6	20	0-2000	0-1600	3,90
BTF 45	180	225	260	120	20,5	80	12	80	18	196	M16	13	40	6	36	0-3190	0-2550	6,90
BTF 50	200	250	290	130	20,5	90	20	78	20	210	M20	17	40	6	25	0-4950	0-3950	9,50

Front fixation with inner screws "M"

Rotation angle +/- 30° - Operating temperature from - 40°C to + 80°C

Fa: Force made by the tensioner with the kit positioned in the a hole

Fb: Force made by the tensioner with the kit positioned in the b hole



## ELASTIC CHAIN TENSIONERS - TYPE BTP



BTP tensioners are suitable for humid or corrosive environments.  
 BTP tensioners are manufactured in plastic with metal inserts.  
 The BTP model has an additional reinforcement screw.

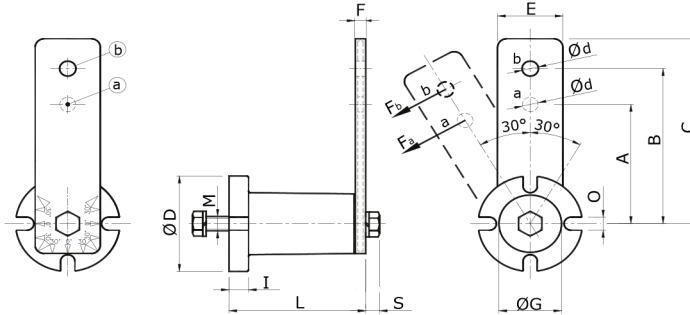

Reference	A	B	C	ØD	Ød	E	F	ØG	I	L	M	O	S	Fa pos. a [N]	Fb pos. b [N]	Kg
BTP 11	60	80	90	40	8,5	24	7	20	6	52	M6x20	7	7,5	0-113	0-85	0,10
BTP 15	80	100	112,5	50	10,5	30	8	30	8	66	M8x25	9	9,2	0-170	0-136	0,20
BTP 18	80	100	115	60	10,5	36	8	35	10	79	M10x30	9	10,5	0-425	0-340	0,26
BTP 27	100	130	155	80	12,5	50	10	48	15	108	M12x40	11	10,5	0-1027	0-790	0,72

Rotation angle + / - 30° - Operating temperature from - 10°C to + 80°C  
 Fa: Force made by the tensioner with the kit positioned in the a hole  
 Fb: Force made by the tensioner with the kit positioned in the b hole

## TENSIONERS BRACKET SUPPORTS - TYPE SBT



SBT support is used to facilitate the mounting of the elastic element on the machine.

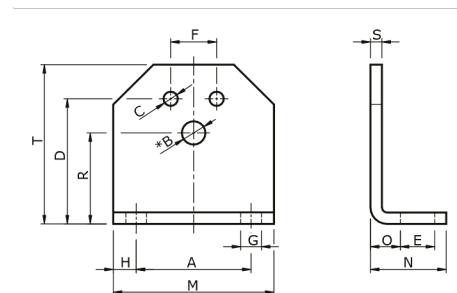
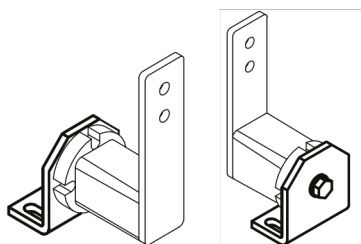

Reference	A	B*	C	D	E	F	G	H	M	N	O	R	S	T	Kg	
SBT 11	30	11	6,5	5,5	35	13	10	7	7,5	45	30	11,5	27	4	46	0,09
SBT 15	40	15	8,5	6,5	44	13	12	7	7,5	55	32	13,5	34	5	58	0,17
SBT 18	50	18	10,5	8,5	55	15,5	20	9,5	10	70	38	16,5	43	6	74	0,29
SBT 27	65	27	12,5	10,5	75	21,5	25	11,5	12,5	90	52	21	57	8	98	0,72
SBT 38	80	38	16,5	12,5	85	24	35	14	15	110	55	21	66	8	116	0,93
SBT 45	100	45	20,5	12,5	110	30	40	18	20	140	66	26	80	10	140	1,82

\* Bore B is used for the fixation of arms type BT and BTf



## SPROCKET WHEEL SET WITH SEALED BALLBEARING

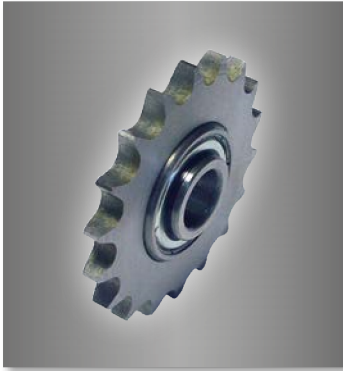

The quality of machining and of mounting of the double sealed ballbearings gives an increased breaking load and a better wear resistance to our products.

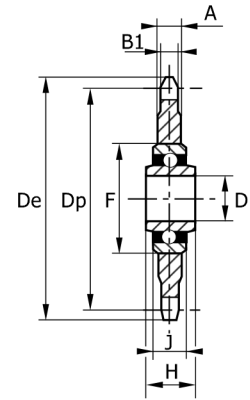
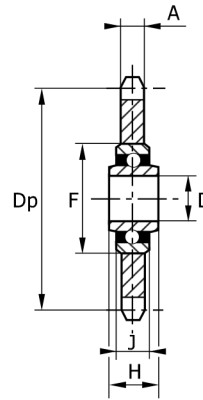
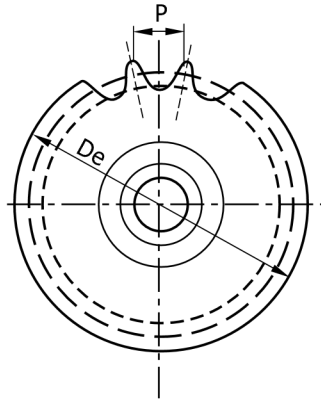

Pitch (mm)	Pitch (inch)	Chain	Reference	Z	De	Dp	B1	A	D	F	H	J	Kg
8	8	05B-1	PTR05B023	23	62,00	58,75	2,8	7,0	16	40	18,3	12	0,13
9,525	3/8" x 7/32"	06B-1	PTR06B021	21	68,00	63,91	5,3	7,0	16	40	18,3	12	0,15
12,7 x 3,18	1/2" x 1/8"	081-1	PTR081018	18	78,90	73,14	3,0	7,0	16	40	18,3	12	0,18
12,7 x 4,76	1/2" x 3/16"	083-1	PTR083016	16	70,90	65,10	4,5	7,0	16	40	18,3	12	0,17
12,7 x 4,76	1/2" x 3/16"	083-1	PTR083018	18	78,90	73,14	4,5	7,0	16	40	18,3	12	0,20
12,7	1/2" x 5/16"	08B-1	PTR08B016	16	69,50	65,10	-	7,2	16	40	18,3	12	0,17
12,7	1/2" x 5/16"	08B-1	PTR08B018	18	77,80	73,14	-	7,2	16	40	18,3	12	0,22
12,7	1/2" x 5/16"	08B-1	PTR08B020	20	85,80	81,19	-	7,2	16	40	18,3	12	0,27
15,875	5/8" x 3/8"	10B-1	PTR10B013	13	73,00	66,32	-	9,1	16	40	18,3	12	0,20
15,875	5/8" x 3/8"	10B-1	PTR10B014	14	78,00	71,34	-	9,1	16	40	18,3	12	0,23
15,875	5/8" x 3/8"	10B-1	PTR10B015	15	83,00	76,36	-	9,1	16	40	18,3	12	0,27
15,875	5/8" x 3/8"	10B-1	PTR10B017	17	93,00	86,30	-	9,1	16	40	18,3	12	0,36
19,05	3/4" x 7/16"	12B-1	PTR12B013	13	87,50	79,59	-	11,1	16	40	18,3	12	0,34
19,05	3/4" x 7/16"	12B-1	PTR12B015	15	99,80	91,63	-	11,1	16	40	18,3	12	0,47
25,4	1" x 17,02	16B-1	PTR16B012	12	109,00	98,14	-	16,2	20	47	17,7	14	0,72
25,4	1" x 17,02	16B-1	PTR16B015	15	133,00	122,17	-	16,2	20	47	17,7	14	0,90
31,75	1" 1/4 x 3/4"	20B-1	PTR20B013	13	147,80	132,65	-	18,5	25	52	21	15	1,64



Dimensions in mm

## SPROCKET WHEEL SET WITH SEALED BALLBEARING - TYPE TR (MACHINED PINS)

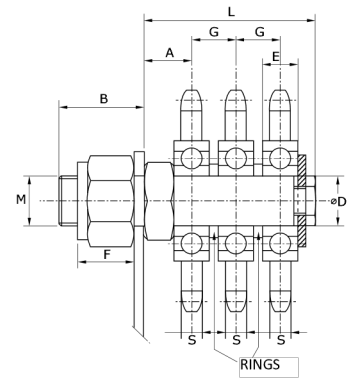
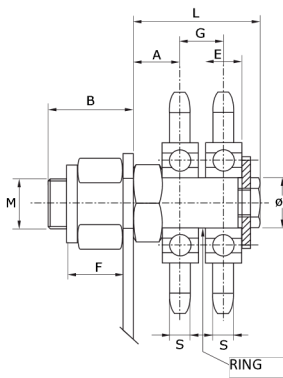
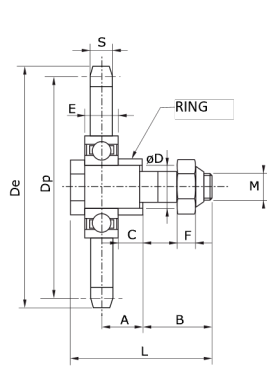

SIMPLEX															Size	Kg
Reference Pin + Wheel	Reference of Wheel only	Chain Pitch	Z	De	Dp	S	M	D	A	B	C	E	F	L		
TR1 03B 017	PT1 03B 017	5	17	29,00	27,20	2,3	M6	6	7	15	4	6	6	28		0,100
TR1 04B 015	PT1 04B 015	6	15	31,10	28,86	2,6	M6	6	7	15	4	6	6	28	11	0,110
TR1 05B 014	PT1 05B 014	8	14	39,20	35,95	2,8	M8	8	7,5	16	4	7	8	30		0,120
TR1 06B 017	PT1 06B 017	9,525	17	55,50	51,83	5,3	M10	12	12	22	7	10	10	44		0,135
TR1 081 013	PT1 081 013	12,7 x 3,3	13	59,40	53,06	3	M10	12	12	22	7	10	10	44	15	0,140
TR1 083 013	PT1 083 013	12,7 x 4,88	13	59,40	53,06	4,5	M10	12	12	22	7	10	10	44		0,145
TR1 08B 017	PT1 08B 017	12,7	17	74,00	69,11	7,2	M12	17	15	26	9	12	12	53	18	0,280
TR1 10B 016	PT1 10B 016	15,875	16	88,30	81,37	9,1	M12	17	15	26	9	12	12	53	27	0,410
TR1 12B 014	PT1 12B 014	19,05	14	93,80	85,61	11,1	M12	17	15	26	9	13	12	53	27	0,490
TR1 16B 012	PT1 16B 012	25,4	12	109,70	98,14	16,2	M20	20	25	28	18	14	17	66	38	0,960
TR1 20B 012	PT1 20B 012	31,75	12	137,00	122,68	18,5	M24	30	40	50	30,5	19	21	115	38 - 45	2,350
TR1 24B 012	PT1 24B 012	38,1	12	161,00	147,22	24,1	M36	40	50	74	38,5	23	29	155	45 - 50	3,250

DUPLEX											Size	Kg
Reference Pin + Wheel	Chain Pitch	Z	M	D	A	B	F	G	L			
TR2 06B 017	9,525	17	M12	12	12	35	10	10,24	33	27	0,235	
TR2 08B 017	12,7	17	M18	17	15	45	12	13,92	44	38	0,600	
TR2 10B 016	15,875	16	M20	17	15	45	12	16,59	46,6	38	0,900	
TR2 12B 014	19,05	14	M20	17	15	45	12	19,46	49,5	38	1,100	
TR2 16B 012	25,4	12	M24	20	24	55	14	31,88	71,8	45	2,000	

TRIPLEX										Size	Kg
Reference Pin + Wheel	Chain Pitch	Z	M	D	A	B	F	G	L		
TR3 06B 017	9,525	17	M12	12	12	35	10	10,24	43	18	0,325
TR3 08B 017	12,7	17	M18	17	15	45	12	13,92	58	27	0,800
TR3 10B 016	15,875	16	M20	17	15	45	12	16,59	63,2	38	1,300
TR3 12 014	19,05	14	M20	17	15	45	12	19,46	69	38	1,600

Protection : white zinc coat

The customer must widen the hole in the elastic element bore when necessary



# SPROCKET WHEEL SET WITH SEALED BALLBEARING - TYPE TF



Chain tensioning wheels in galvanized steel with sealed bearing, perfect to adjust the tension of simplex, duplex and triplex chains.

Maximum speed of 1m/sec - Maximum operating temperature : 100°C.

The kits are supplied complete with galvanized screws.

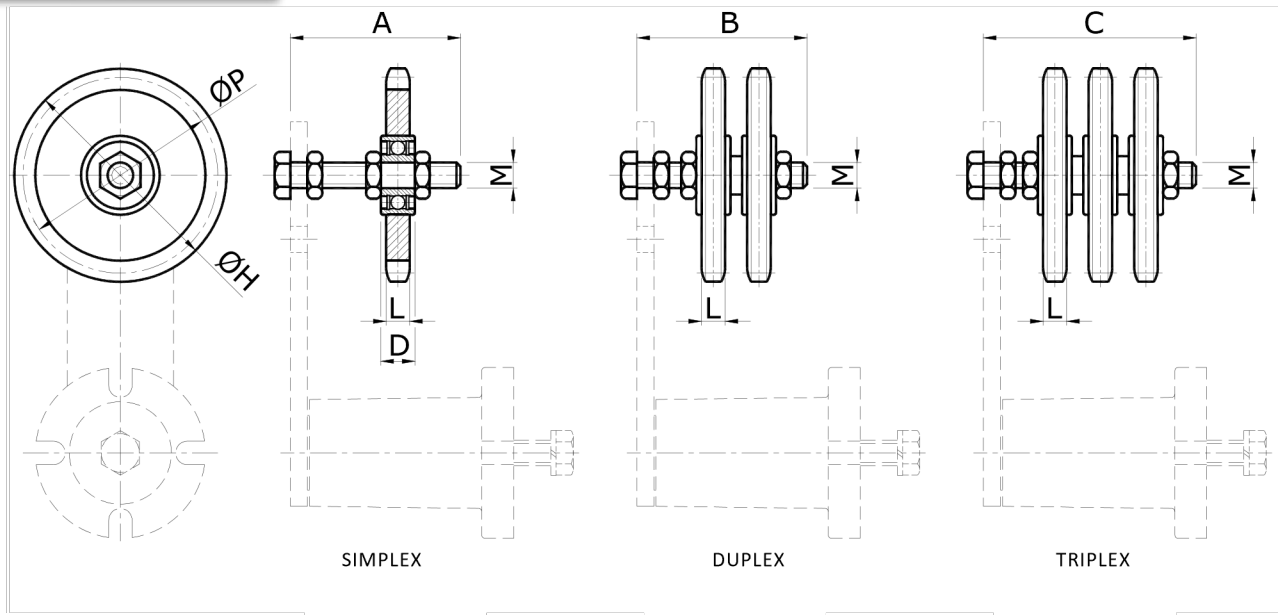

Simplex chain reference (S)	Duplex chain reference (D)	Triplex chain reference (T)	Chains	Size	Z*	A	B	C	D	ØH	L	M	ØP	Kg		
														S	D	T
TF1 06B 015 BT15	TF2 06B 015 BT15		3/8"x7/32"	15	15	55	55		9	49,3	5,3	10	45,81	0,13	0,23	
TF1 06B 015 BT18	TF2 06B 015 BT18	TF3 06B 015 BT18	3/8"x7/32"	18	15	55	60	70	9	49,3	5,3	10	45,81	0,13	0,23	0,26
TF1 08B 015 BT18	TF2 08B 015 BT18		1/2"x5/16"	18	15	55	60		9	65,5	7,2	10	61,09	0,21	0,37	
		TF3 08B 015 BT27	1/2"x5/16"	27	15			90	12	65,5	7,2	12	61,09		0,51	
TF1 10B 015 BT27	TF2 10B 015 BT27	TF3 10B 015 BT27	5/8"x3/8"	27	15	80	90	90	12	83,0	9,1	12	76,36	0,38	0,60	0,96
		TF3 10B 015 BT38	5/8"x3/8"	38	15			120	15	83,0	9,1	20	76,36		1,26	
TF1 12B 015 BT27	TF2 12B 015 BT27		3/4"x7/16"	27	15	80	90	90	12	99,8	11,1	12	91,63	0,56	1,00	
TF1 12B 015 BT38	TF2 12B 015 BT38	TF3 12B 015 BT38	3/4"x7/16"	38	15	80	90	120	15	99,8	11,1	20	91,63	0,81	1,35	1,60
TF1 16B 013 BT38	TF2 16B 013 BT38		1"X17,02 mm	38	13	100	120	120	15	117,0	16,2	20	106,12	1,23	2,10	
		TF3 16B 013 BT45	1"X17,02 mm	45	13			160	15	117,0	16,2	20	106,12		2,92	
TF1 20B 013 BT45	TF2 20B 013 BT45	TF3 20B 013 BT45	1" 1/4x3/4"	45	13	100	140	160	15	147,8	18,5	20	132,65	2,28	3,60	5,20
TF1 24B 011 BT45	TF2 24B 011 BT45	TF3 24B 011 BT45	1" 1/2x1"	45	11	140	140	180	15	150,0	24,1	20	135,21	2,33	4,20	6,10

\*Z : Number of teeth



## POLYETHYLENE SLIDING BLOCKS - TYPE OVR ACCESSORIES



Elliptical sliding block OVR in polyethylene with a high molecular density, suitable to tension simplex, duplex or triplex chains which have a speed below 0.35 m/s and operating temperatures lower than 80°C.

This type of sliding block is particular suitable for installations close to the sprocket and for reduced center distance. Its particular shape allows its use on both sides, granting a lifetime which is double compared to a traditional block.

The kits are supplied complete with galvanized steel screws and bolts (kit with stainless steel screws and bolts also possible).

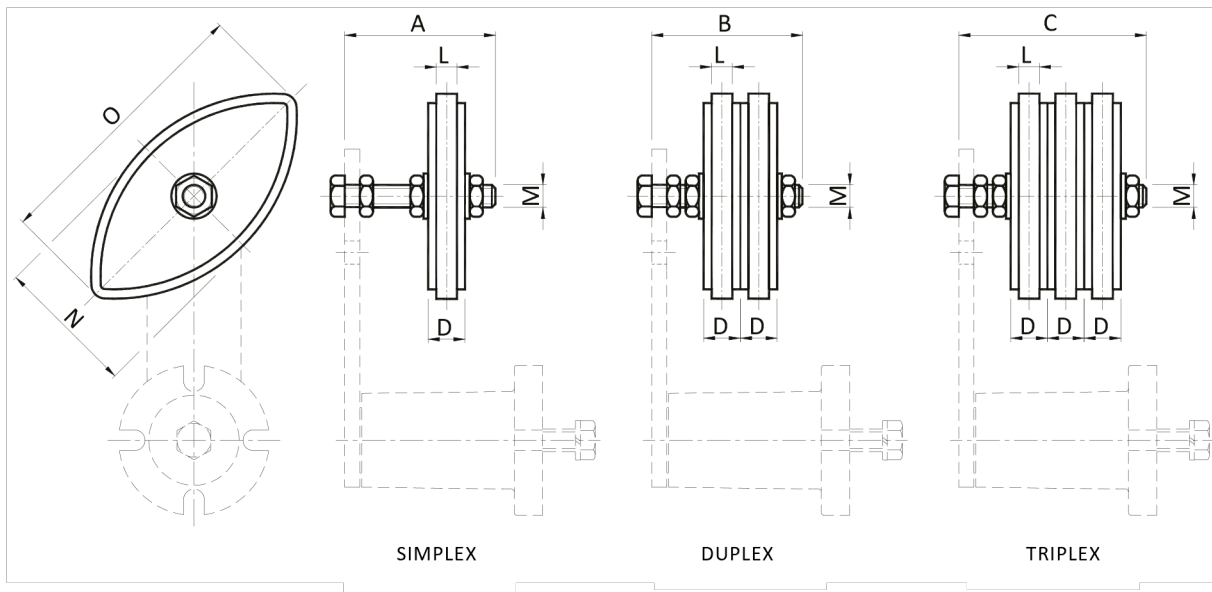

For duplex chains, use two blocks side by side.  
For triplex chains, use 3 blocks side by side.

Simplex chain reference (S)	Duplex chain reference (D)	Triplex chain reference (T)	Chains	Size									Kg		
					A	B	C	D	L	M	N	O	S	D	T
OVR 06B1 BT 11	OVR 06B2 BT11		3/8" x 7/32"	11	45	45		10,2	5	M 8	40	75	0,09	0,10	
		OVR 06B3 BT15	3/8" x 7/32"	15		55		10,2	5	M10	40	75			0,11
OVR 08B1 BT15	OVR 08B2 BT15		1/2" x 5/16"	15	55	55		13,9	7	M10	50	96	0,10	0,11	
OVR 08B1 BT18	OVR 08B2 BT18	OVR 08B3 BT18	1/2" x 5/16"	18	55	60	75	13,9	7	M10	50	96	0,11	0,12	0,13
OVR 10B1 BT18	OVR 10B2 BT18		5/8" x 3/8"	18	55	70		16,6	9	M10	65	126	0,12	0,14	
		OVR 10B3 BT27	5/8" x 3/8"	27		90		16,6	9	M12	65	126			0,16
OVR 12B1 BT18	OVR 12B2 BT18		3/4" x 7/16"	18	60	70		19,5	11	M10	74	148	0,13	0,15	
OVR 12B1 BT27	OVR 12B2 BT27	OVR 12B3 BT27	3/4" x 7/16"	27	80	80	100	19,5	11	M12	74	148	0,20	0,22	0,25





## ROLLERS : TYPE RLP & RLA ACCESSORIES

**POLYAMID ROLLER -  
TYPE RLP**

Roller installed on self-lubricated bearings, suitable to tension the belts.

Maximum operating temperature : 70°C for polyamid rollers  
Maximum operating temperature : 100°C for galvanized rollers

The kits are supplied with galvanized bolts and screws.

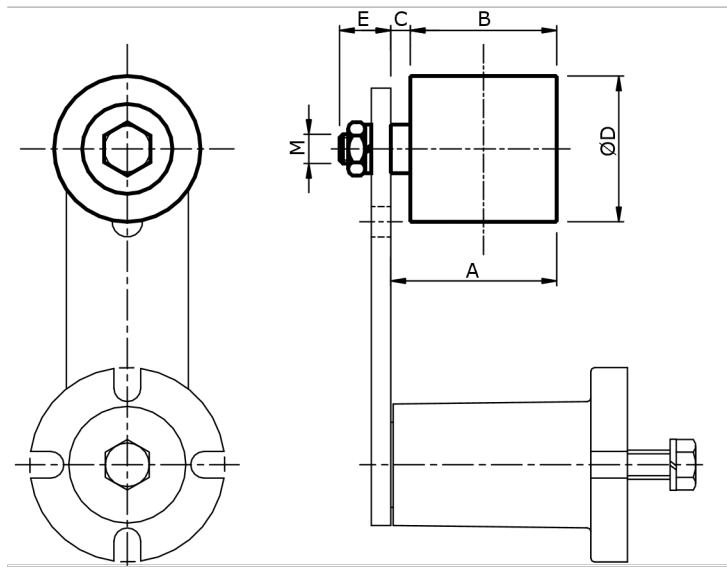
**GALVANIZED ROLLER -  
TYPE RLA**

Polyamid roller			Galvanized roller			A	B	C	ØD	E	max speed [rpm]	Size 
Reference	M	Kg	Reference	M	Kg							
RLP 30	M8	0.08	RLA 30	M8	0.16	38	35	3	30	13	8000	11
RLP 40	M10	0.18	RLA 40	M10	0.37	51	45	6	40	16	8000	15-18
RLP 60	M12	0.40	RLA 60	M16	0.85	68	60	8	60	21	6000	27
RLP 80	M20	1.20	RLA 80	M20	2.09	99	90	9	80	28	5000	38
RLP 90	M20	1.70	RLA 90	M20	2.44	142	135	7	90	27	4500	45



## TRAPEZOIDAL PULLEYS : TYPE KSP ACCESSORIES



Cast iron pulley for trapezoidal belts installed on self-lubricated bearings.

Pulleys with other profiles or timing pulleys are possible on request.

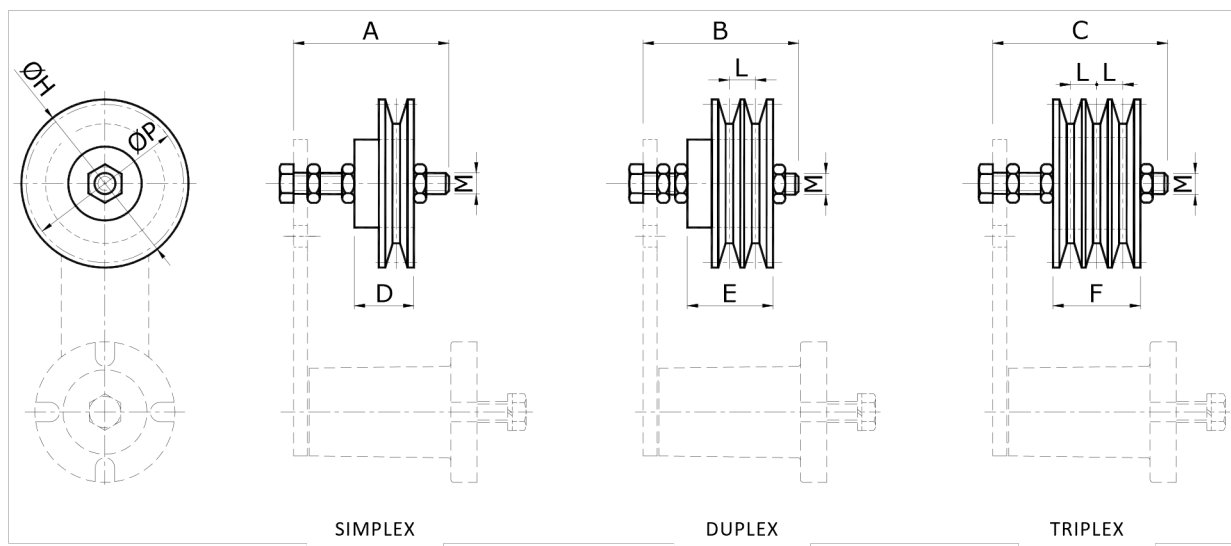

Simplex belt reference (S)	Duplex belt reference (D)	Triplex belt reference (T)	Belt	Size	A	B	C	D	E	F	ØH	L	ØP	M	S	Kg	
																D	T
KSPZ 063/1	KSPZ 063/2	KSPZ 063/3	SPZ	18	55	60	70	24	35	40	67	12	63	M10	0,40	0,70	1,10
KSPA 090/1	KSPA 090/2	KSPA 090/3	SPA	27	80	80	80	34	49	50	95,6	15	90	M12	1,00	1,70	1,80
KSPB 125/1	KSPB 125/2		SPB	27	80	90		41	60		132	19	125	M12	1,90	2,80	
		KSPB 125/3	SPB	38			120			63	132	19	125	M20			3,50



# AXIAL TENSIONERS TAS



**Type TASZ with spring in galvanized steel**  
**Type TASX with spring in stainless steel**

**Material :** Tensioners TAS are completely made in plastic with stainless steel screws.  
 The inside spring can be in galvanized or stainless steel.

**Use :** Maximum operating temperature: 80°C.  
 All the bodies are supplied with a preloading system.  
 Maximum stroke: 40 mm.

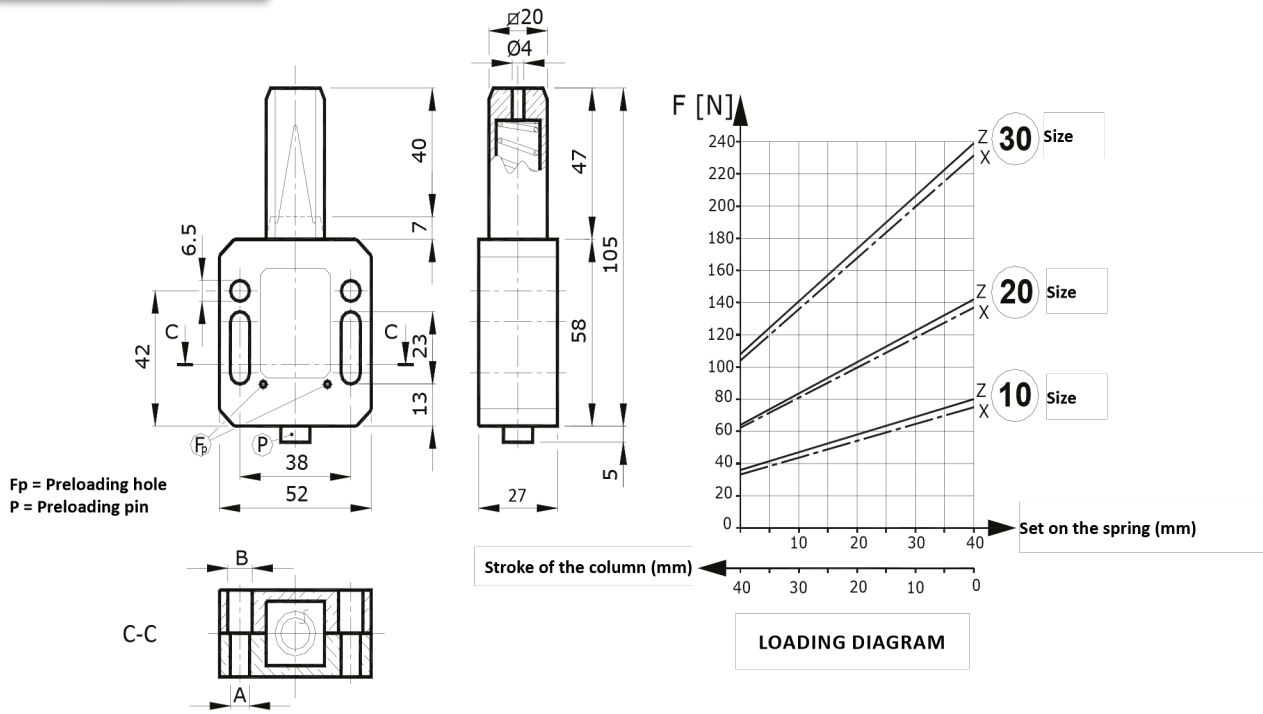

A	B	With galvanized spring		With stainless steel spring	
		Reference	Newton*	Reference	Newton*
6,5	6,5	TAS 10-6Z	36-79	TAS 10-6X	35-77
8,5	8,5	TAS 10-8Z	36-79	TAS 10-8X	35-77
6,5	8,5	TAS 10-6/8Z	36-79	TAS 10-6/8X	35-77
6,5	6,5	TAS 20-6Z	64-142	TAS 20-6X	63-139
8,5	8,5	TAS 20-8Z	64-142	TAS 20-8X	63-139
6,5	8,5	TAS 20-6/8Z	64-142	TAS 20-6/8X	63-139
6,5	6,5	TAS 30-6Z	108-239	TAS 30-6X	105-233
8,5	8,5	TAS 30-8Z	108-239	TAS 30-8X	105-233
6,5	8,5	TAS 30-6/8Z	108-239	TAS 30-6/8X	105-233

\* The first figure gives the spring pressure at the end of the stroke, the second figure when totally compressed.

### FOR ALL ORDERS PLEASE PRECISE :

- Axial tightener type : TAS - TAD - TBD - TCD
- Block type : PF - PG - PC - PV - QG - QV
- Chain type : reference ISO and pitch in mm
- Spring type : to precise only if stainless steel is needed (galvanized by default)

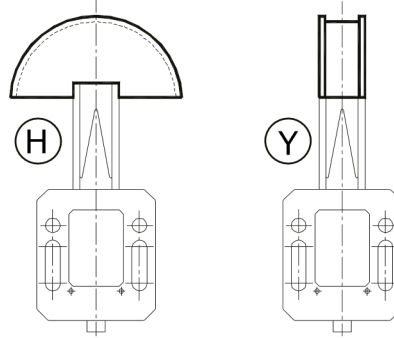
**KIT FOR CHAIN TENSIONERS - POLYETHYLENE SLIDING BLOCK- TYPE PF**

Positioning of the sliding block

**Material :** Polyethylene sliding block with high molecular density with bolts and nuts in stainless steel.

**Use :** Operating speed  $\leq 20\text{m/min}$ .  
Sliding block operating temperature  $\leq 70^\circ\text{C}$ .

It is suitable for reduced interaxis.

Please precise the positioning of the sliding block (H or Y), by default it will be supplied with H execution.

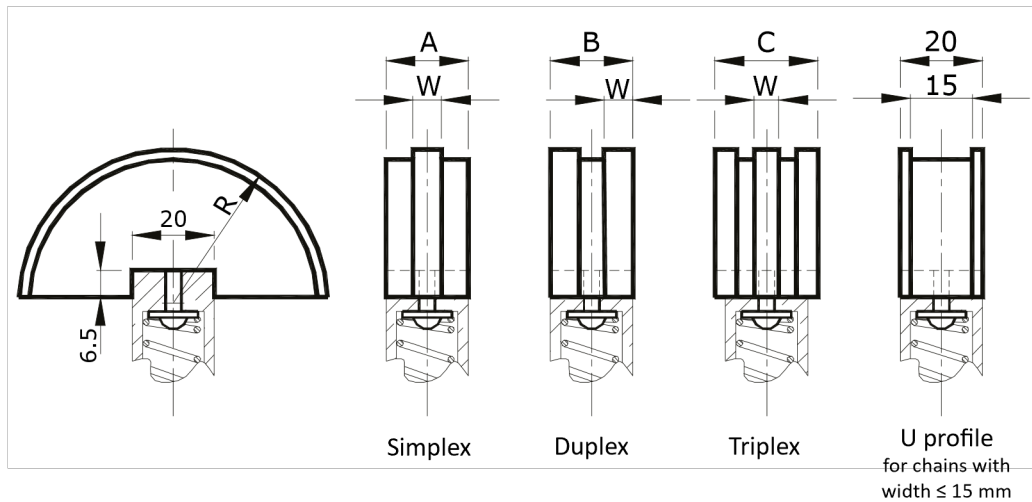

Sliding block reference				Chain	Size	R	A	B	C	W	Kg			
Simplex Reference	Duplex Reference	Triplex Reference	U profile Reference								Simplex	Duplex	Triplex	U profile
PF AS			PF AU	6 mm	10	37,5	20			2,3	0,03		0,03	
PF OS	PF OD		PF AU	8 mm	10	37,5	20	20		2,5	0,03	0,03	0,03	
		PF OT		8 mm	20	37,5			20	2,5			0,04	
		PF OT		8 mm	30	37,5			20	2,5			0,04	
PF 1S	PF 1D		PF AU	3/8"x7/32"	10	37,5	20	20		5	0,03	0,03	0,03	
PF 1S	PF 1D	PF 1T	PF AU	3/8"x7/32"	20	37,5	20	20	25	5	0,03	0,03	0,04	
		PF 1T		3/8"x7/32"	30	37,5			25	5			0,04	
PF 2S	PF 2D			1/2"x5/16"	20	37,5	20	20		7	0,03	0,04		
PF 2S	PF 2D			1/2"x5/16"	30	37,5	20	20		7	0,03	0,04		
PF 3S				5/8"x3/8"	20	40	20			9	0,04			
PF 3S	PF 3D			5/8"x3/8"	30	40	20	25		9	0,04	0,08		
PF 4S				3/4"x7/16"	30	40	20			11	0,05			

This product will be supplied as a KIT : Axial tightener on one side / sliding block on the other side



# AXIAL TENSIONERS TAD



**Type TADZ with spring in galvanized steel**  
**Type TADX with spring in stainless steel**

**Material :** Tensioners TAD are completely made in plastic with stainless steel screws. The inside spring can be in galvanized steel (TADZ) or stainless steel (TADX).

**Use :** Elastic chain tensioner.  
 Maximum operating temperature: 80°C.  
 All the bodies are supplied with a preloading system.  
 Maximum stroke: 40 mm.

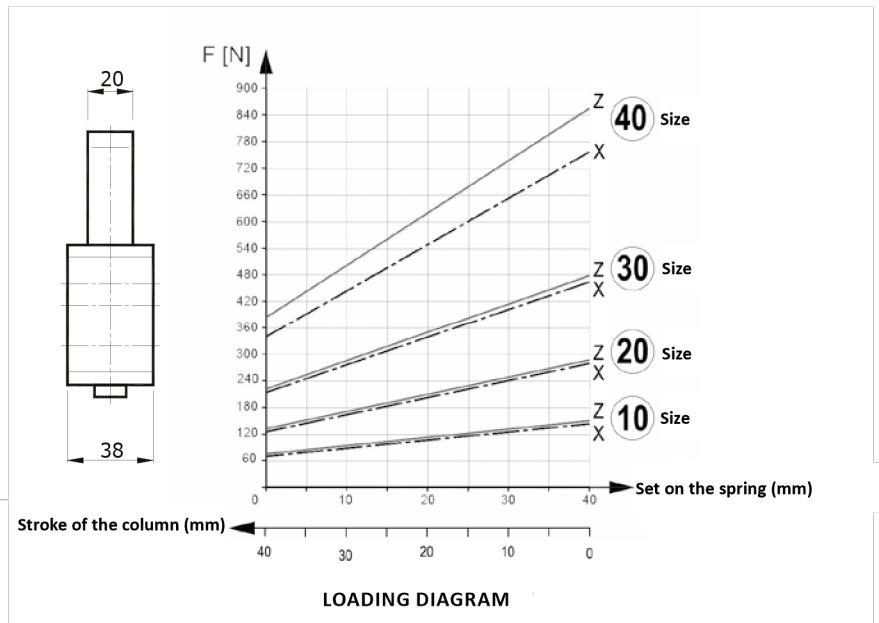
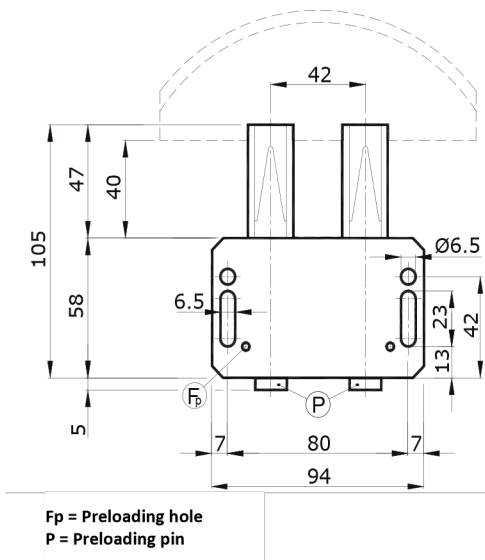

With galvanized spring		With stainless steel spring		Kg
Reference	Newton*	Reference	Newton*	
TAD 10Z	72 - 158	TAD 10X	70 - 154	0,24
TAD 20Z	128 - 284	TAD 20X	126 - 278	0,24
TAD 30Z	216 - 478	TAD 30X	210 - 466	0,24
TAD 40Z	388 - 859	TAD 40X	343 - 759	0,24

\* The first figure gives the spring pressure at the end of the stroke, the second figure when totally compressed.

### FOR ALL ORDERS PLEASE PRECISE :

- Axial tightener type : TAS - TAD - TBD - TCD
- Sliding block type : PF - PG - PC - PV - QG - QV
- Chain type : reference ISO and pitch in mm
- Spring type : to precise only if stainless steel is needed (galvanized by default)



Dimensions in mm

## KIT FOR CHAIN TENSIONERS - POLYETHYLENE SLIDING BLOCK – TYPE PG



**Material:** Polyethylene sliding block with high molecular density with bolts and nuts in stainless steel.

**Use:** Lowered semicircular profile suitable for medium to big interaxis  
 Operating speed  $\leq 20\text{m/min}$ .  
 Sliding block operating temperature  $\leq 70^\circ\text{C}$ .

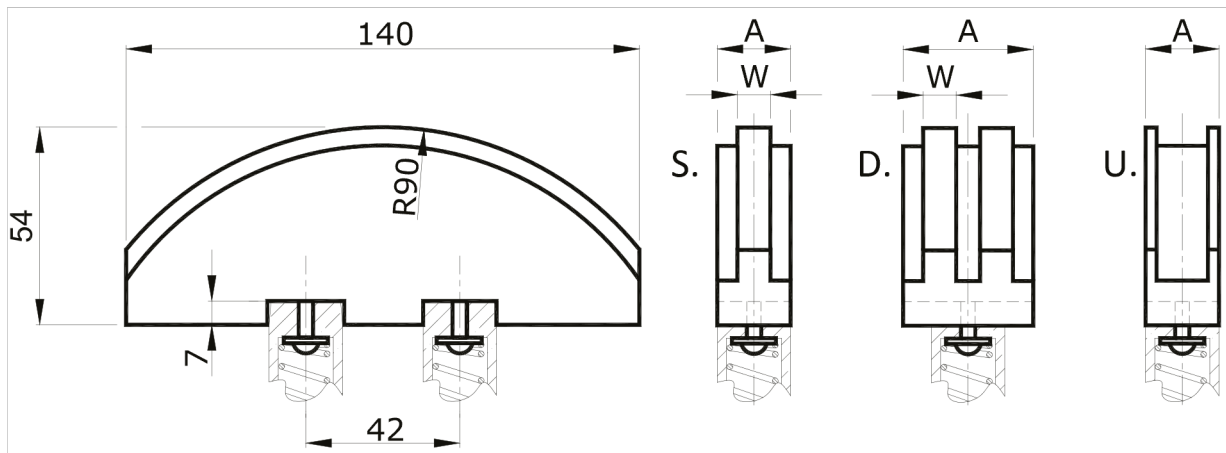

Type	Chain	A	W	Kg
PG 1 U	$\leq 06\text{-B1}$	20		0,11
PG 2 S	08-B1	20	7	0,11
PG 3 S	10-B1	20	9	0,11
PG 4 S	12-B1	20	11	0,11
PG 5 S	16-B1	20	16	0,14
PG 0 D	05-B2	20	2,5	0,11
PG 1 D	06-B2	20	5	0,11
PG 2 D	08-B2	20	7	0,11
PG 3 D	10-B2	25	9	0,14
PG 4 D	12-B2	30	11	0,16



# COMPLETE AXIAL TENSIONERS TAD + SLIDING BLOCK PG

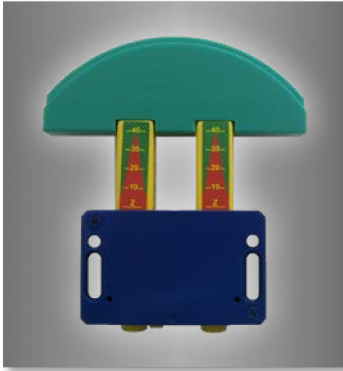

Type TADZ with spring in galvanized steel  
 Type TADX with spring in stainless steel

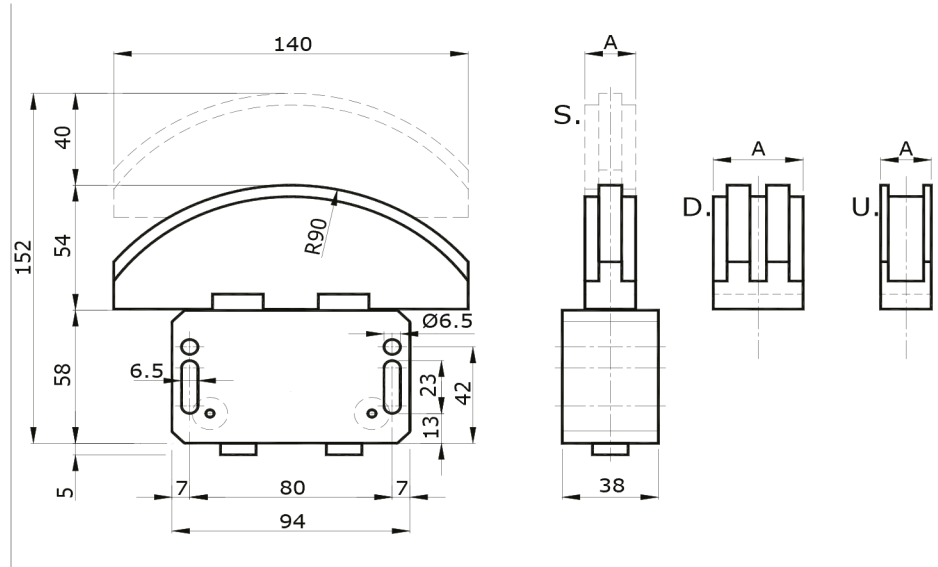

Chain DIN 8187 ISO	With galvanized spring			With stainless steel spring			
	TADZ+PG	TADZ	PG	TADX	TADX+PG		
≤06-B1	≤3/8"x7/32"	TAD10ZPG1U	TAD 10 Z	PG U	20	TAD 10 X	TAD10XPG1U
08-B1	1/2"x5/16"	TAD10ZPG2S	TAD 10 Z	PG 2 S	20	TAD 10 X	TAD10XPG2S
08-B1	1/2"x5/16"	TAD20ZPG2S	TAD 20 Z	PG 2 S	20	TAD 20 X	TAD20XPG2S
10-B1	5/8"x3/8"	TAD10ZPG3S	TAD 10 Z	PG 3 S	20	TAD 10 X	TAD10XPG3S
10-B1	5/8"x3/8"	TAD20ZPG3S	TAD 20 Z	PG 3 S	20	TAD 20 X	TAD20XPG3S
10-B1	5/8"x3/8"	TAD30ZPG3S	TAD 30 Z	PG 3 S	20	TAD 30 X	TAD30XPG3S
12-B1	3/4"x7/16"	TAD10ZPG4S	TAD 10 Z	PG 4 S	20	TAD 10 X	TAD20XPG4S
12-B1	3/4"x7/16"	TAD20ZPG4S	TAD 20 Z	PG 4 S	20	TAD 20 X	TAD20XPG4S
12-B1	3/4"x7/16"	TAD30ZPG4S	TAD 30 Z	PG 4 S	20	TAD 30 X	TAD30XPG4S
16-B1	1"x17,02mm	TAD30ZPG5S	TAD 30 Z	PG 5 S	20	TAD 30 X	TAD30XPG5S
16-B1	1"x17,02mm	TAD40ZPG5S	TAD 40 Z	PG 5 S	20	TAD 40 X	TAD40XPG5S
05-B2	8mm	TAD10ZPG0D	TAD 10 Z	PG 0 D	20	TAD 10 X	TAD10XPG0D
06-B2	3/8"x7/32"	TAD10ZPG1D	TAD 10 Z	PG 1 D	20	TAD 10 X	TAD10XPG1D
06-B2	3/8"x7/32"	TAD20ZPG1D	TAD 20 Z	PG 1 D	20	TAD 20 X	TAD20XPG1D
08-B2	1/2"x5/16"	TAD20ZPG2D	TAD 20 Z	PG 2 D	20	TAD 20 X	TAD20XPG2D
10-B2	5/8"x3/8"	TAD20ZPG3D	TAD 20 Z	PG 3 D	25	TAD 20 X	TAD20XPG3D
10-B2	5/8"x3/8"	TAD30ZPG3D	TAD 30 Z	PG 3 D	25	TAD 30 X	TAD30XPG3D
12-B2	3/4"x7/16"	TAD20ZPG4D	TAD 20 Z	PG 4 D	30	TAD 20 X	TAD20XPG4D
12-B2	3/4"x7/16"	TAD30ZPG4D	TAD 30 Z	PG 4 D	30	TAG 30 X	TAD30XPG4D

Triplex chain tensioners only on request.



## AXIAL TIGHTENER TBD

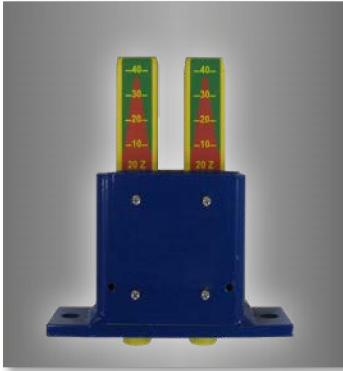

**Type TBDZ with spring in galvanized steel**  
**Type TBDX with spring in stainless steel**

**Material:** Outside case in painted steel and inside components in plastic.  
 Bolts in stainless steel. Springs inside can be supplied in galvanized steel (TBDZ) or in stainless steel (TBDX).

**Use:** Elastic chain tensioner.  
 Maximum operating temperature: 80°C.  
 All the bodies are supplied with a preloading system.  
 Maximum stroke: 40 mm.

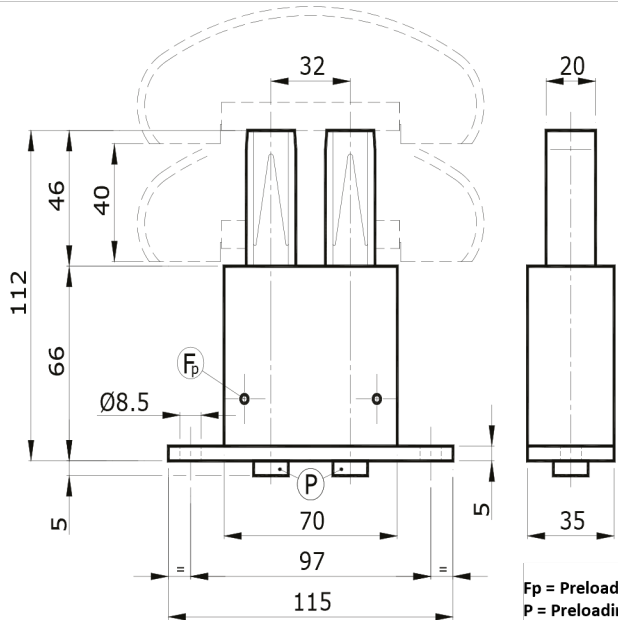

Fp = Preloading hole  
 P = Preloading pin

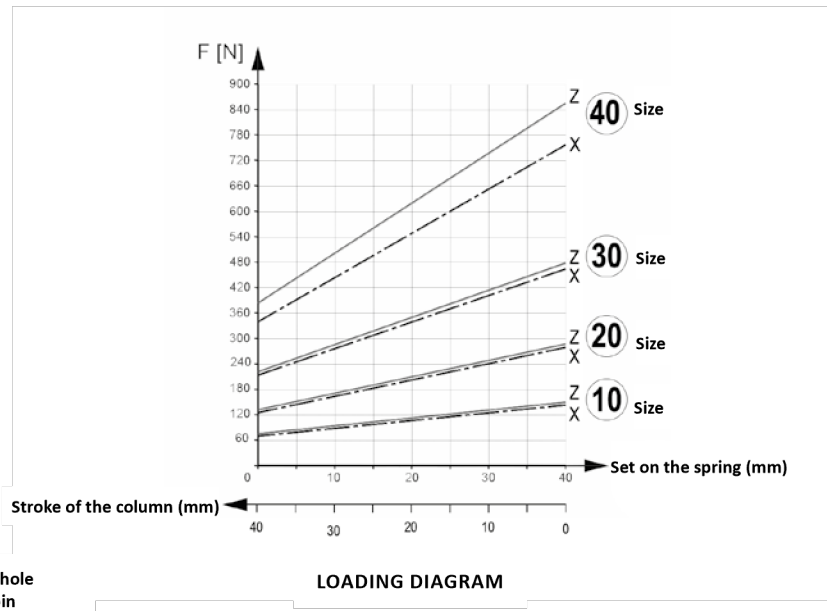

With galvanized spring		With stainless steel spring		Kg
Reference	Newton*	Reference	Newton*	
TBD 10Z	72 - 158	TBD 10X	70 - 154	0,60
TBD 20Z	128 - 284	TBD 20X	126 - 278	0,60
TBD 30Z	216 - 478	TBD 30X	210 - 466	0,60
TBD 40Z	388 - 859	TBD 40X	343 - 759	0,60

\* The first figure gives the spring pressure at the end of the stroke, the second figure when totally compressed.

### FOR ALL ORDERS PLEASE PRECISE :

- Axial tightener type : TAS - TAD - TBD - TCD
- Block type : PF - PG - PC - PV - QG - QV
- Chain type : reference ISO and pitch in mm
- Spring type : to precise only if stainless steel is needed (galvanized by default)





Dimensions in mm

## KIT FOR AXIAL TIGHTENER - POLYETHYLENE SLIDING BLOCK – TYPE PC

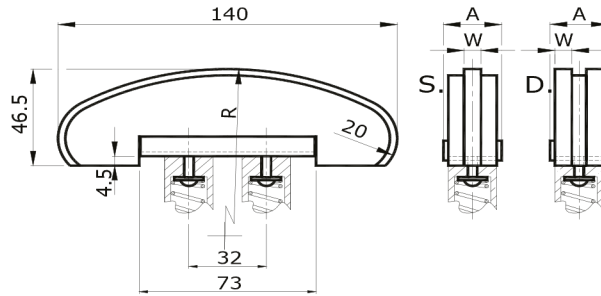

**Material:** Polyethylene sliding block with high molecular density with bolts in stainless steel. Steel profile.

**Use:** Lowered semicircular profile suitable for medium to big interaxis  
 Operating speed  $\leq 20\text{m/min}$ .  
 Sliding block operating temperature  $\leq 70^\circ\text{C}$ .

Reference	Chain	A	R	W	Kg
PC 0 S	05-B1	24	120	2,5	0,13
PC 1 S	06-B1	24	120	5	0,14
PC 2 S	08-B1	24	120	7	0,14
PC 3 S	10-B1	24	140	9	0,11
PC 4 S	12-B1	24	140	11	0,16
PC 5 S	16-B1	29	160	16	0,18
PC 6 S	20-B1	29	160	18	0,28
PC 0 D	05-B2	24	120	2,5	0,13
PC 1 D	06-B2	24	120	5	0,14
PC 2 D	08-B2	24	120	7	0,18
PC 3 D	10-B2	29	140	9	0,18
PC 4 D	12-B2	34	140	11	0,33
PC 5 D	16-B2	52	160	16	0,56

## KIT FOR AXIAL TIGHTENER - POLYETHYLENE SLIDING BLOCK – TYPE PV

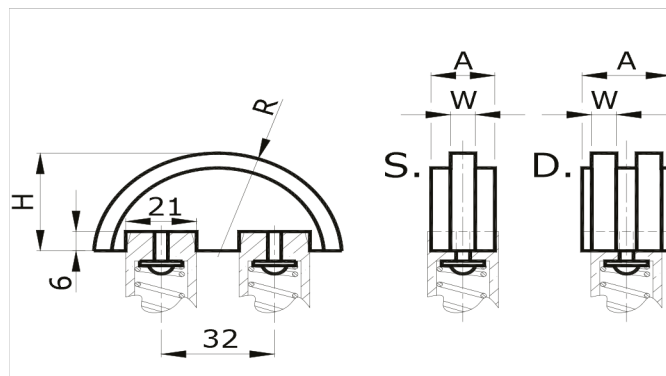

**Material:** Polyethylene sliding block with high molecular density with bolts in stainless steel.

**Use:** Lowered semicircular profile suitable for reduced interaxis.  
 Operating speed  $\leq 20\text{m/min}$ .  
 Sliding block operating temperature  $\leq 70^\circ\text{C}$ .

Reference	Chain	A	R	H	W	Kg
PV 1 S	06-B1	18	35	33	5	0,03
PV 2 S	08-B1	18	35	33	7	0,03
PV 3 S	10-B1	18	45	43	9	0,05
PV 4 S	12-B1	18	45	43	11	0,08
PV 1 D	06-B2	18	35	33	5	0,03
PV 2 D	08-B2	21	35	33	7	0,03
PV 3 D	10-B2	25	45	43	9	0,08
PV 4 D	12-B2	30	45	43	11	0,09



# COMPLETE AXIAL TENSIONERS TBD + SLIDING BLOCK PC

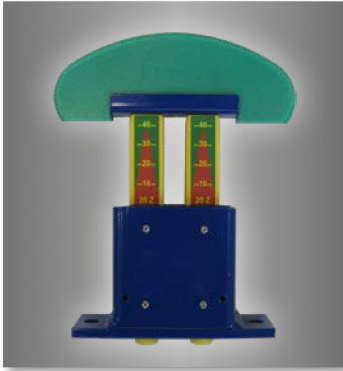

Type TBDZ with spring in galvanized steel  
 Type TBDX with spring in stainless steel

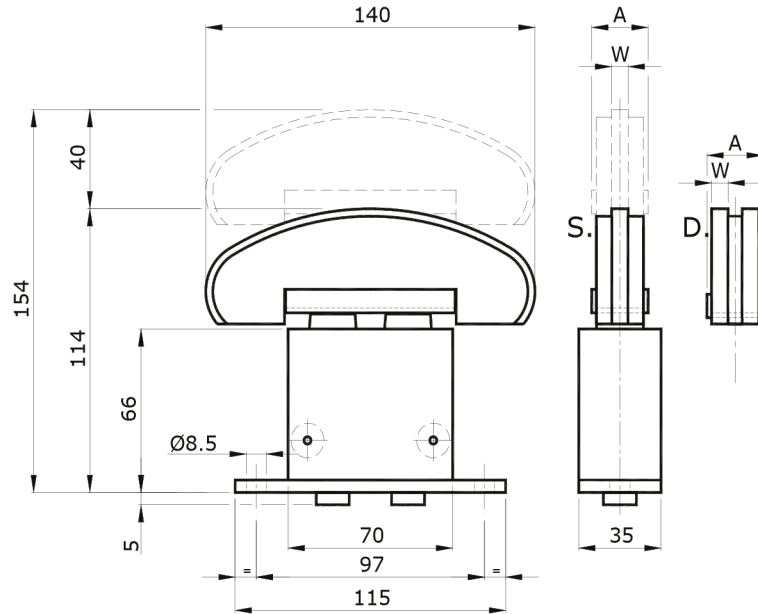

Chain DIN 8187 ISO	With galvanized spring				With stainless steel spring			
	TBDZ + PC	TBDZ	PC		TBDX	TBDX+PC		
05-B1	8mm	TBD10ZPC0S	TBD 10 Z	PC 0 S	24	2,5	TBD 10 X	TBD10XPC0S
06-B1	3/8"x7/32"	TBD10ZPC1S	TBD 10 Z	PC 1 S	24	5	TBD 10 X	TBD10XPC1S
06-B1	3/8"x7/32"	TBD20ZPC1S	TBD 20 Z	PC 1 S	24	5	TBD 20 X	TBD20XPC1S
08-B1	1/2"x5/16"	TBD10ZPC2S	TBD 10 Z	PC 2 S	24	7	TBD 10 X	TBD10XPC2S
08-B1	1/2"x5/16"	TBD20ZPC2S	TBD 20 Z	PC 2 S	24	7	TBD 20 X	TBD20XPC2S
10-B1	5/8"x3/8"	TBD20ZPC3S	TBD 20 Z	PC 3 S	24	9	TBD 20 X	TBD20XPC3S
10-B1	5/8"x3/8"	TBD30ZPC3S	TBD 30 Z	PC 3 S	24	9	TBD 30 X	TBD30XPC3S
12-B1	3/4"x7/16"	TBD20ZPC4S	TBD 20 Z	PC 4 S	24	11	TBD 20 X	TBD20XPC4S
12-B1	3/4"x7/16"	TBD30ZPC4S	TBD 30 Z	PC 4 S	24	11	TBD 30 X	TBD30XPC4S
16-B1	1"x17,02mm	TBD30ZPC5S	TBD 30 Z	PC 5 S	29	16	TBD 30 X	TBD30XPC5S
16-B1	1"x17,02mm	TBD40ZPC5S	TBD 40 Z	PC 5 S	29	16	TBD 40 X	TBD40XPC5S
20-B1	1 1/4"x3/4"	TBD30ZPC6S	TBD 30 Z	PC 6 S	29	18	TBD 30 X	TBD30XPC6S
20-B1	1 1/4"x3/4"	TBD40ZPC6S	TBD 40 Z	PC 6 S	29	18	TBD 40 X	TBD40XPC6S
05-B2	8mm	TBD10ZPC0D	TBD 10 Z	PC 0 D	24	2,5	TBD 10 X	TBD10XPC0D
06-B2	3/8"x7/32"	TBD10ZPC1D	TBD 10 Z	PC 1 D	24	5	TBD 10 X	TBD10XPC1D
06-B2	3/8"x7/32"	TBD20ZPC1D	TBD 20 Z	PC 1 D	24	5	TBD 20 X	TBD20XPC1D
08-B2	1/2"x5/16"	TBD20ZPC2D	TBD 20 Z	PC 2 D	24	7	TBD 20 X	TBD20XPC2D
10-B2	5/8"x3/8"	TBD20ZPC3D	TBD 20 Z	PC 3 D	29	9	TBD 20 X	TBD20XPC3D
10-B2	5/8"x3/8"	TBD30ZPC3D	TBD 30 Z	PC 3 D	29	9	TBD 30 X	TBD30XPC3D
12-B2	3/4"x7/16"	TBD30ZPC4D	TBD 30 Z	PC 4 D	34	11	TBD 30 X	TBD30XPC4D
16-B2	1"x17,02mm	TBD30ZPC5D	TBD 30 Z	PC 5 D	52	16	TBD 30 X	TBD30XPC5D
16-B2	1"x17,02mm	TBD40ZPC5D	TBD 40 Z	PC 5 D	52	16	TBD 40 X	TBD40XPC5D

Triplex chain tensioners only on request.



# COMPLETE AXIAL TENSIONERS TBD + SLIDING BLOCK PV

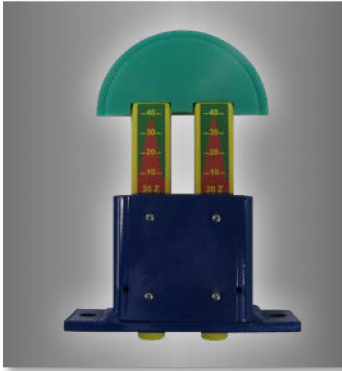

Type TBDZ with spring in galvanized steel  
 Type TBDX with spring in stainless steel

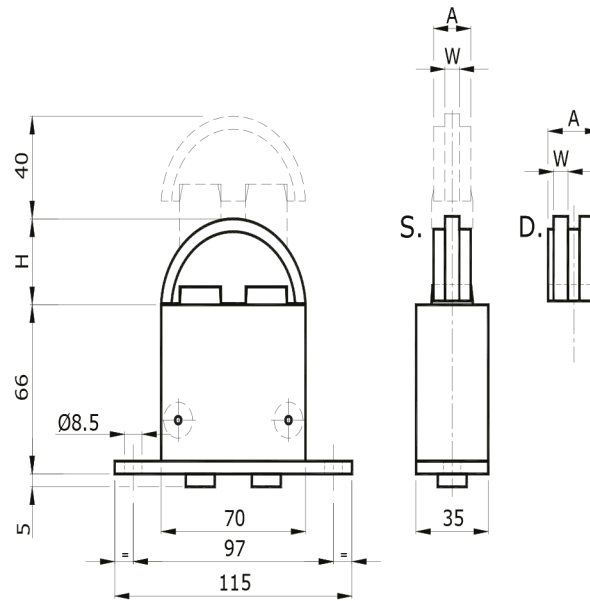

Chain DIN 8187 ISO	With galvanized spring			With stainless steel spring		
	TBDZ + PV	TBDZ	PV	TBDX + PV	TBDX	
			A H W			
06-B1 3/8"x7/32"	<b>TBD10ZPV1S</b>	TBD 10 Z	PV 1 S	TBD 10 X	<b>TBD10XPV1S</b>	
06-B1 3/8"x7/32"	<b>TBD20ZPV1S</b>	TBD 20 Z	PV 1 S	TBD 20 X	<b>TBD20XPV1S</b>	
08-B1 1/2"x5/16"	<b>TBD10ZPV2S</b>	TBD 10 Z	PV 2 S	TBD 10 X	<b>TBD10XPV2S</b>	
08-B1 1/2"x5/16"	<b>TBD20ZPV2S</b>	TBD 20 Z	PV 2 S	TBD 20 X	<b>TBD20XPV2S</b>	
10-B1 5/8"x3/8"	<b>TBD20ZPV3S</b>	TBD 20 Z	PV 3 S	TBD 20 X	<b>TBD20XPV3S</b>	
10-B1 5/8"x3/8"	<b>TBD30ZPV3S</b>	TBD 30 Z	PV 3 S	TBD 30 X	<b>TBD30XPV3S</b>	
12-B1 3/4"x7/16"	<b>TBD20ZPV4S</b>	TBD 20 Z	PV 4 S	TBD 20 X	<b>TBD20XPV4S</b>	
12-B1 3/4"x7/16"	<b>TBD30ZPV4S</b>	TBD 30 Z	PV 4 S	TBD 30 X	<b>TBD30XPV4S</b>	
06-B2 3/8"x7/32"	<b>TBD10ZPV1D</b>	TBD 10 Z	PV 1 D	TBD 10 X	<b>TBD10XPV1D</b>	
06-B2 3/8"x7/32"	<b>TBD20ZPV1D</b>	TBD 20 Z	PV 1 D	TBD 20 X	<b>TBD20XPV1D</b>	
08-B2 1/2"x5/16"	<b>TBD20ZPV2D</b>	TBD 20 Z	PV 2 D	TBD 20 X	<b>TBD20XPV2D</b>	
10-B2 5/8"x3/8"	<b>TBD20ZPV3D</b>	TBD 20 Z	PV 3 D	TBD 20 X	<b>TBD20XPV3D</b>	
10-B2 5/8"x3/8"	<b>TBD30ZPV3D</b>	TBD 30 Z	PV 3 D	TBD 30 X	<b>TBD30XPV3D</b>	
12-B2 3/4"x7/16"	<b>TBD30ZPV4D</b>	TBD 30 Z	PV 4 D	TBD 30 X	<b>TBD30XPV4D</b>	

Triplex chain tensioners only on request.



## AXIAL TENSIONERS TCD

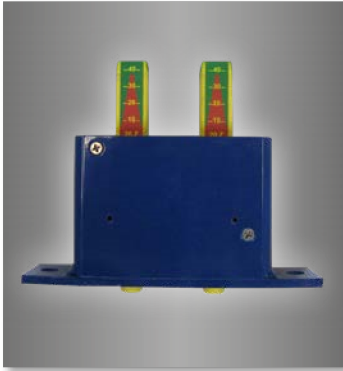

**Type TCDZ with spring in galvanized steel**  
**Type TCDX with spring in stainless steel**

**Material :** Outside case in painted steel and inside components in plastic.  
 Bolts in stainless steel. Springs inside can be supplied in galvanized steel (TCDZ) or in stainless steel (TCDX).

**Use :** Elastic chain tensioner.  
 Maximum operating temperature: 80°C.  
 All the bodies are supplied with a preloading system.  
 Maximum stroke: 40 mm.

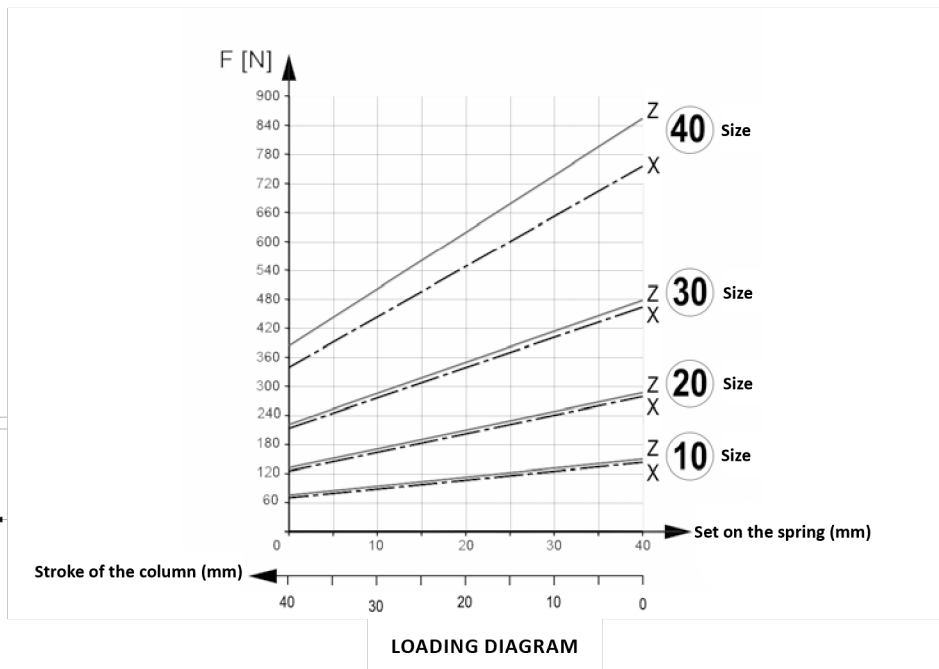
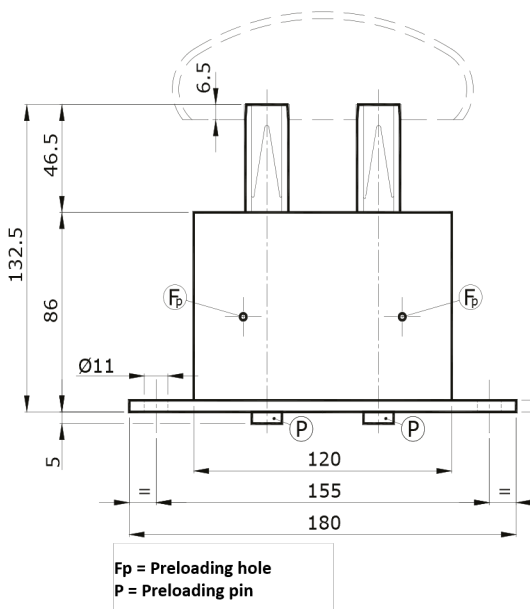

With galvanized spring		With stainless steel spring		Kg
Reference	Newton*	Reference	Newton*	
TCD 10Z	72 - 158	TCD 10X	70 - 154	1,25
TCD 20Z	128 - 284	TCD 20X	126 - 278	1,25
TCD 30Z	216 - 478	TCD 30X	210 - 466	1,25
TCD 40Z	388 - 859	TCD 40X	343 - 759	1,25

\* The first figure gives the spring pressure at the end of the stroke, the second figure when totally compressed.

**FOR ALL ORDERS PLEASE PRECISE :**

- Axial tightener type : TAS - TAD - TBD - TCD
- Block type : PF - PG - PC - PV - QG - QV
- Chain type : reference ISO and pitch in mm
- Spring type : to precise only if stainless steel is needed (galvanized by default)



Dimensions in mm

## KIT FOR AXIAL TENSIONERS - POLYETHYLENE SLIDING BLOCK – TYPE QG

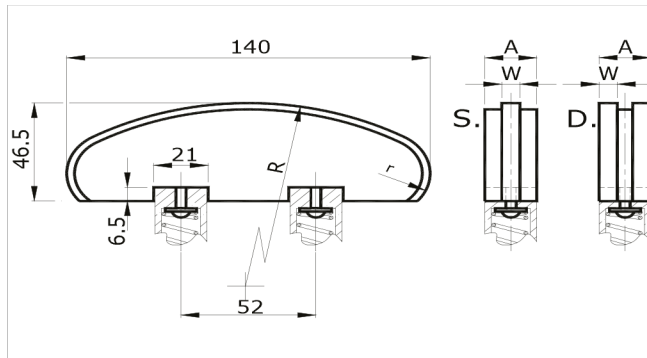

**Material :** Polyethylene sliding block with high molecular density with bolts in stainless steel.

**Use :** Lowered semicircular profile suitable for medium to big interaxis  
 Operating speed  $\leq 20\text{m/min}$ .  
 Sliding block operating temperature  $\leq 70^\circ\text{C}$ .

Reference	Chain	A	R	W	Kg
QG 0 S	05-B1	20	120	2,5	0,07
QG 1 S	06-B1	20	120	5	0,07
QG 2 S	08-B1	20	120	7	0,08
QG 3 S	10-B1	20	140	9	0,10
QG 4 S	12-B1	20	140	11	0,12
QG 5 S	16-B1	25	160	16	0,20
QG 6 S	20-B1	25	160	18	0,20
QG 7 S	24-B1	30	160	24	0,35
QG 0 D	05-B2	20	120	2,5	0,07
QG 1 D	06-B2	20	120	5	0,08
QG 2 D	08-B2	20	120	7	0,08
QG 3 D	10-B2	25	140	9	0,12
QG 4 D	12-B2	30	140	11	0,25
QG 5 D	16-B2	48	160	16	0,50
QG 6 D	20-B2	55	160	18	1,30
QG 7 D	24-B2	70	160	24	1,40

## KIT FOR AXIAL TENSIONERS - POLYETHYLENE SLIDING BLOCK – TYPE QV

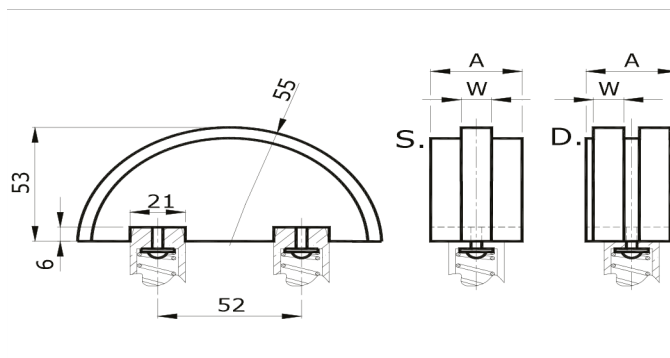

**Material :** Polyethylene sliding block with high molecular density with bolts in stainless steel.

**Use :** Lowered semicircular profile suitable for reduced interaxis  
 Operating speed  $\leq 20\text{m/min}$ .  
 Sliding block operating temperature  $\leq 70^\circ\text{C}$ .

Reference	Chain	A	W	Kg
QV 45	12-B1	33	11	0,08
QV 55	16-B1	33	16	0,08
QV 2 D	08-B2	33	7	0,08
QV 3 D	10-B2	33	9	0,09
QV 4 D	12-B2	33	11	0,10



# COMPLETE AXIAL TENSIONERS TCD + SLIDING BLOCK QG

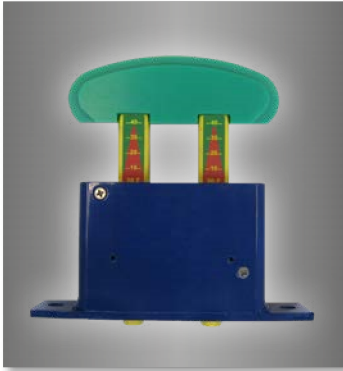

Type TCDZ with spring in galvanized steel  
 Type TCDX with spring in stainless steel

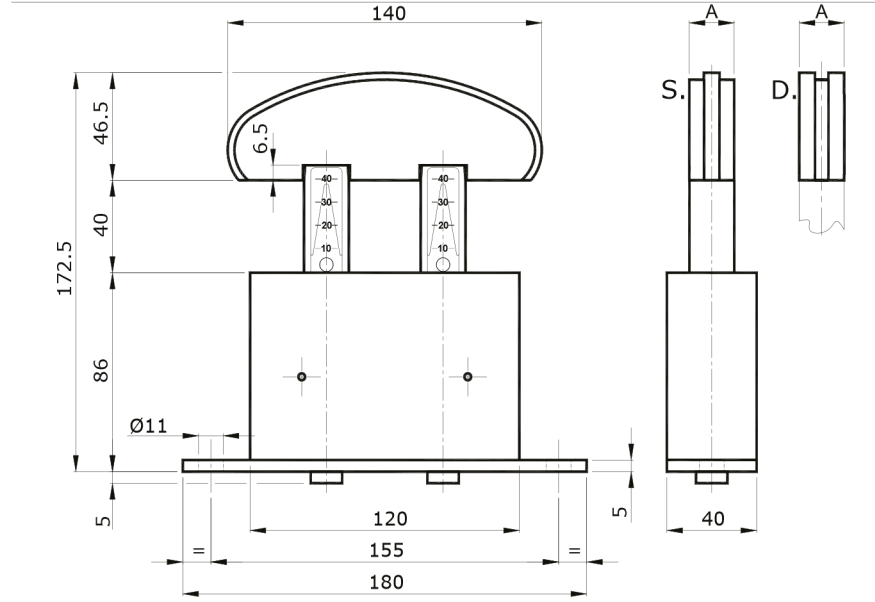

Chain DIN 8187 ISO	With galvanized spring			With stainless steel spring			
	TCDZ + QG	TCDZ	QG	TCDX	TCDX + QG		
05-B1	8mm	TCD10ZQG0S	TCD 10 Z	QG 0 S	20	TCD 10 X	TCD10XQG0S
06-B1	3/8"x7/32"	TCD10ZQG1S	TCD 10 Z	QG 1 S	20	TCD 10 X	TCD10XQG1S
06-B1	3/8"x7/32"	TCD20ZQG1S	TCD 20 Z	QG 1 S	20	TCD 20 X	TCD20XQG1S
08-B1	1/2"x5/16"	TCD10ZQG2S	TCD 10 Z	QG 2 S	20	TCD 10 X	TCD10XQG2S
08-B1	1/2"x5/16"	TCD20ZQG2S	TCD 20 Z	QG 2 S	20	TCD 20 X	TCD20XQG2S
10-B1	5/8"x3/8"	TCD20ZQG3S	TCD 20 Z	QG 3 S	20	TCD 20 X	TCD20XQG3S
10-B1	5/8"x3/8"	TCD30ZQG3S	TCD 30 Z	QG 3 S	20	TCD 30 X	TCD30XQG3S
12-B1	3/4"x7/16"	TCD30ZQG4S	TCD 30 Z	QG 4 S	20	TCD 30 X	TCD30XQG4S
16-B1	1"x17,02mm	TCD30ZQG5S	TCD 30 Z	QG 5 S	25	TCD 30 X	TCD30XQG5S
16-B1	1"x17,02mm	TCD40ZQG5S	TCD 40 Z	QG 5 S	25	TCD 40 X	TCD40XQG5S
20-B1	1"1/4x3/4"	TCD30ZQG6S	TCD 30 Z	QG 6 S	25	TCD 30 X	TCD30XQG6S
20-B1	1"1/4x3/4"	TCD40ZQG6S	TCD 40 Z	QG 6 S	25	TCD 40 X	TCD40XQG6S
24-B1	1"1/2x1"	TCD30ZQG7S	TCD 30 Z	QG 7 S	30	TCD 30 X	TCD30XQG7S
24-B1	1"1/2x1"	TCD40ZQG7S	TCD 40 Z	QG 7 S	30	TCD 40 X	TCD40XQG7S
05-B2	8mm	TCD10ZQG0D	TCD 10 Z	QG 0 D	20	TCD 10 X	TCD10XQG0D
06-B2	3/8"x7/32"	TCD10ZQG1D	TCD 10 Z	QG 1 D	20	TCD 10 X	TCD10XQG1D
06-B2	3/8"x7/32"	TCD20ZQG1D	TCD 20 Z	QG 1 D	20	TCD 20 X	TCD20XQG1D
08-B2	1/2"x5/16"	TCD20ZQG2D	TCD 20 Z	QG 2 D	20	TCD 20 X	TCD20XQG2D
10-B2	5/8"x3/8"	TCD20ZQG3D	TCD 20 Z	QG 3 D	25	TCD 20 X	TCD20XQG3D
10-B2	5/8"x3/8"	TCD30ZQG3D	TCD 30 Z	QG 3 D	25	TCD 30 X	TCD30XQG3D
12-B2	3/4"x7/16"	TCD30ZQG4D	TCD 30 Z	QG 4 D	30	TCD 30 X	TCD30XQG4D
16-B2	1"x17,02mm	TCD30ZQG5D	TCD 30 Z	QG 5 D	48	TCD 30 X	TCD30XQG5D
16-B2	1"x17,02mm	TCD40ZQG5D	TCD 40 Z	QG 5 D	48	TCD 40 X	TCD40XQG5D
20-B2	1"1/4x3/4"	TCD30ZQG6D	TCD 30 Z	QG 6 D	55	TCD 30 X	TCD30XQG6D
20-B2	1"1/4x3/4"	TCD40ZQG6D	TCD 40 Z	QG 6 D	55	TCD 40 X	TCD40XQG6D
24-B2	1"1/2x1"	TCD30ZQG7D	TCD 30 Z	QG 7 D	70	TCD 30 X	TCD30XQG7D
24-B2	1"1/2x1"	TCD40ZQG7D	TCD 40 Z	QG 7 D	70	TCD 40 X	TCD40XQG7D

Triplex chain tensioners only on request.



# COMPLETE AXIAL TENSIONERS TCD + SLIDING BLOCK QV

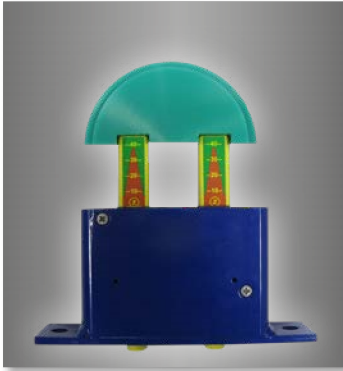

Type TCDZ with spring in galvanized steel  
 Type TCDX with spring in stainless steel

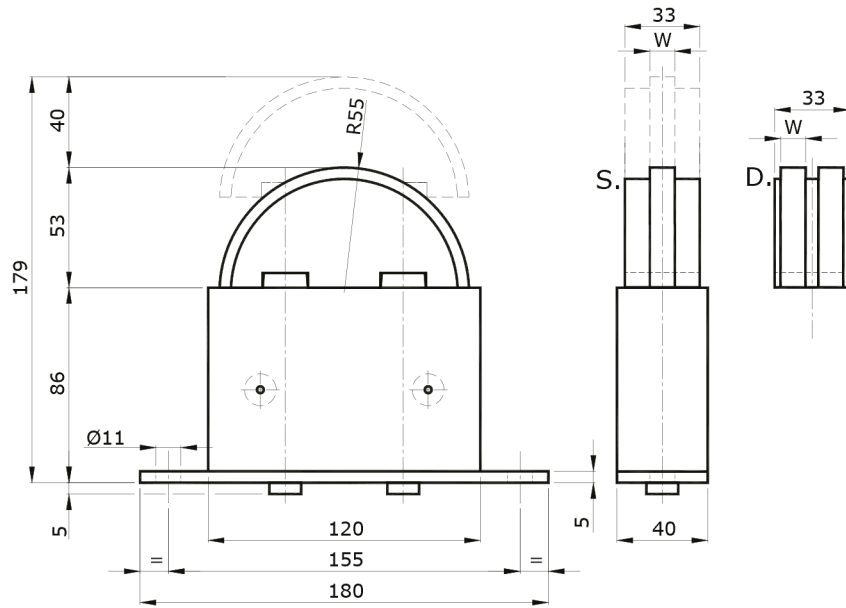

		With galvanized spring			With stainless steel spring			
		TCDZ + QV	TCDZ	QV	TCDX	TCDX + QV		
Chain DIN 8187 ISO					A			
	12-B1	3/4"x7/16"	TCD20ZQV4S	TCD 20 Z	QV 4 S	11	TCD 20 X	TCD20XQV4S
	12-B1	3/4"x7/16"	TCD30ZQV4S	TCD 30 Z	QV 4 S	11	TCD 30 X	TCD30XQV4S
	16-B1	1"x17,02mm	TCD30ZQV5S	TCD 30 Z	QV 5 S	16	TCD 30 X	TCD30XQV5S
	16-B1	1"x17,02mm	TCD40ZQV5S	TCD 40 Z	QV 5 S	16	TCD 40 X	TCD40XQV5S
	08-B2	1/2"x5/16"	TCD20ZQV2D	TCD 20 Z	QV 2 D	7	TCD 20 X	TCD20XQV2D
	10-B2	5/8"x3/8"	TCD20ZQV3D	TCD 20 Z	QV 3 D	9	TCD 20 X	TCD20XQV3D
	10-B2	5/8"x3/8"	TCD30ZQV3D	TCD 30 Z	QV 3 D	9	TCD 30 X	TCD30XQV3D
12-B2	3/4"x7/16"	TCD30ZQV4D	TCD 30 Z	QV 4 D	11	TCD 30 X	TCD30XQV4D	

Triplex chain tensioners only on request.



## TECHNICAL INFORMATION - ASSEMBLY INSTRUCTIONS

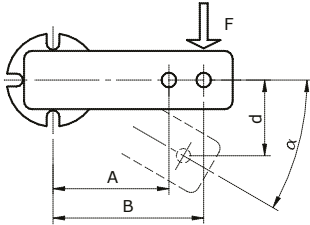

Type	Preloading angle $\alpha < 10^\circ\text{C}$				Preloading angle $\alpha < 20^\circ\text{C}$				Preloading angle $\alpha < 30^\circ\text{C}$			
	A	B	A	B	A	B	A	B	A	B	A	B
	F [N]	d [mm]	F [N]	d [mm]	F [N]	d [mm]	F [N]	d [mm]	F [N]	d [mm]	F [N]	d [mm]
BT 11 / BTF 11	15	14	20	10	40	28	53	20	84	40	113	30
BT 15 / BTF 15	25	17	31	14	65	34	81	27	136	50	170	40
BT 18 / BTF 18	75	17	93	14	180	34	225	27	340	50	425	40
BT 27 / BTF 27	150	22	195	17	380	44	494	34	790	65	1027	50
BT 38 / BTF 38	290	30	362	24	730	60	912	47	1600	87	2000	70
BT 45 / BTF 45	500	39	625	31	1300	78	1625	61	2550	112	3190	90
BT 50 / BTF 50	600	43	750	34	1700	86	2125	68	4000	125	5000	100

To preload the tensioner, clamp a little the fixing screw (1) then turn the body of the tightener with a wrench (2) to the wanted preloading angle. Clamp the fixing screw (V) to the torque in the table below.

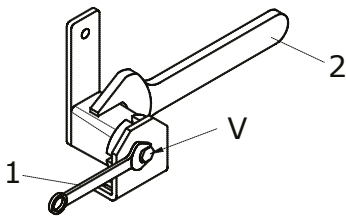

Type	Torque (Nm)						
	Size						
	11	15	18	27	38	45	50
BT	10	25	49	89	210	410	750
BTF	7	17	41	83	145	355	690

## TECHNICAL INFORMATION - EXAMPLES OF INSTALLATIONS

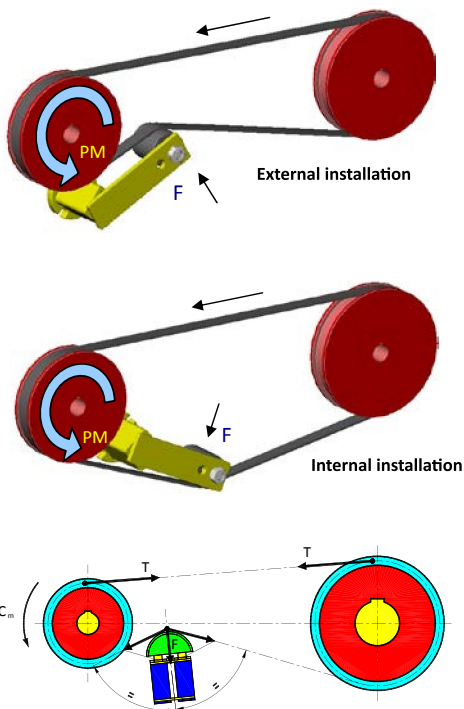
**CORRECT !**

**WRONG !**
