

AC01



THE MOTION - TRANSFER SPECIALISTS



AURORA BEARING COMPANY...

**Manufacturer and worldwide supplier
of the highest quality rod ends,
spherical bearings, and
journal bushings
anywhere!**

General Information

In 1971 a new company entered the rod end and spherical bearing marketplace. This new firm, Aurora Bearing Company, soon became a major force in the rod end industry.

A strict "Quality discipline" covering all phases of business including basic product design, marketing efforts, engineering, customer concern, timely delivery, and all phases of manufacturing has advanced Aurora Bearing Company to the leadership role in the industrial marketplace.

By the middle of the 1980's this total quality reputation was recognized by the aircraft airframe industry, and Aurora Bearing Company was solicited by the most prestigious airframe manufacturers to build products for them to their specifications. This prompted the decision to seriously enter the aircraft market, and by 1988 Aurora Bearing Company was soliciting aircraft business on a controlled basis only, in order to insure consistent customer satisfaction. These efforts resulted in a smooth and successful entry into the aircraft marketplace.

Aurora Bearing Company now produces standard and special spherical bearings, rod ends and bushings, for aircraft manufacturers, their subcontractors, and approved aerospace

distributors. These customers span the entire aerospace industry including; Ultra Light Aircraft, General Aviation Aircraft, small and large Commercial Jet Liners, Military Aircraft, Space related applications up to and including critical areas of the International Space Station.

Incorporated into this catalog are the standard lines of spherical bearings, rod ends and bushings manufactured by Aurora Bearing Company. We also pride ourselves in working closely with aircraft and space designers and engineering groups relative to the most stringent requirements. A sample of these are pictured on the back cover of this catalog.

Aurora Bearing Company's quality system ABC-9000, has been surveyed, approved, and is subject to stringent ongoing reviews by many of the most prestigious aerospace customers.

A very competent international sales force, working with our dedicated engineering staff, is now in place for marketing these products worldwide, and is available and anxious to assist and provide practical and sound solutions to bearing application problems and challenges.

SECTION ONE:

Military Approved Bearings.

We have received approval of our AT3200 PTFE Liner System (See page 31) to SAE-AS81820 (formerly Mil-B-81820), our spherical bearings to SAE-AS14101 through SAE-AS14104 (formerly MS14101 through MS14104), our rod ends to SAE-AS81935 (formerly Mil-B-81935), our PTFE lined bushings to SAE-AS81934 (formerly Mil-B-81934). Total traceabilities are maintained through manufacturing up to and including shipping.

SECTION TWO:

Aircraft Bearings and Rod Ends not requiring Military Approval

These bearings and rod ends are manufactured under the same quality and SPC systems as the Military approved bearings. Aurora Bearing Company has not sought approval for bearings in this section. However, many of the bearings and rod ends have been approved to individual customer specifications and or standards. Total traceabilities are maintained through manufacturing up to and including shipping.

SECTION THREE:

General Purpose Rod Ends and Spherical Bearings

Products listed in this section are used by the General Aviation, Experimental, Ultra Light aircraft industries, and in non-critical applications by Commercial Aircraft manufacturers. These bearings and rod ends are manufactured employing strict quality requirements. Total traceabilities are maintained on all parts except those on pages 28, 29, 30, and 31.

SECTION FOUR:

Engineering Information

This section includes general engineering information frequently used by aircraft designers. For additional or more specific engineering needs, contact our engineering department.



Contents

Part Number Designation	Page No.
SECTION ONE:	
<u>SAE-AS81935 MILITARY APPROVED ROD ENDS</u>	
ASM-T/ASB-T Male Rod Ends.....	2-3
ASW-T/ASG-T Female Rod Ends.....	4-5
<u>SAE-AS14101, SAE-AS14102, SAE-AS14103 & SAE-AS14104 MILITARY APPROVED SPHERICAL BEARINGS</u>	
ANC-TG/ANC-T Narrow Spherical Bearings.....	6-7
AWC-TG/AWC-T Wide Spherical Bearings.....	8-9
<u>SAE-AS81934 Sleeve Bearings - PTFE LINED</u>	
AJB-TFA/TFC Flanged Journal Bushings.....	10-11
AJB-TA/TC Plain Journal Bushings.....	12-13
SECTION TWO:	
<u>METAL TO METAL AIRCRAFT ROD ENDS</u>	
ASM/ASB Male Rod Ends.....	14
ASW/ASG Female Rod Ends.....	15
<u>METAL TO METAL AIRCRAFT SPHERICAL BEARINGS</u>	
NC-G/NC Narrow Spherical Bearings.....	16
WC-G/WC Wide Spherical Bearings.....	17
<u>HIGH MISALIGNMENT MALE ROD ENDS</u>	
HXAM-TM-500 Male Rod Ends.....	18
<u>HIGH MISALIGNMENT SPHERICAL BEARINGS</u>	
HAB-T-500 Spherical Bearings.....	19
SECTION THREE:	
<u>GENERAL AVIATION ROD ENDS</u>	
GMM-M/GMB-M Male Rod Ends.....	20
GMW-M/GMG-M Female Rod Ends.....	21
MM-M-500/MB-M-500 Male Rod Ends.....	22
MW-M-500/MG-M-500 Female Rod Ends.....	23
MM-TM-500/MB-TM-500 Male Rod Ends.....	24
MW-TM-500/MG-TM-500 Female Rod Ends.....	25
MM-M-M-500 Metric Male Rod Ends.....	26
MW-M-M-500/MG-M-M-500 Metric Female Rod Ends.....	27
CM/CB Male Rod Ends.....	28
CW/CG Female Rod Ends.....	29
<u>GENERAL AVIATION SPHERICAL BEARINGS</u>	
COM/COM-T Spherical Bearings.....	30
AIB/SIB/MIB/MIB-T Spherical Bearings.....	31
SECTION FOUR:	
<u>ENGINEERING INFORMATION</u>	
Installation of Spherical Bearings.....	32-34
PTFE Liner Information.....	35
Major Specification Approvals.....	36
Conversion Tables - Inch/Metric.....	37



ASM-T & ASB-T Male Rod Ends
High Strength - Aerospace Series
SAE-AS81935/1

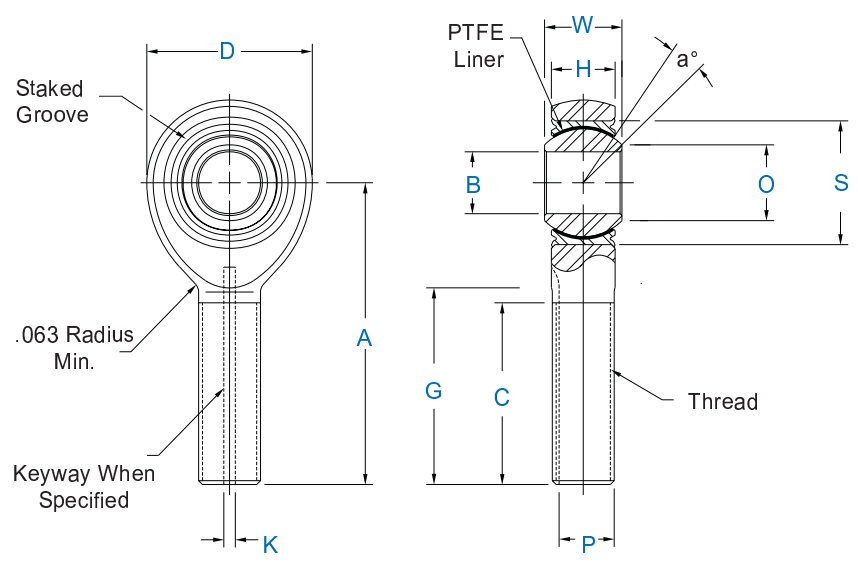

MILITARY NO.		AURORA NO.		DIMENSIONS IN INCHES										
Right Hand	Left Hand	Right Hand	Left Hand	B +.0000 -.0005	W +.000 -.002	H ± .005	A ± .010	D ± .010	O Min.	S Max. Housing I.D.	Ball Dia. Ref.	G +.000 -.020	K +.005 -.000	P +.000 -.005
M81935/1-03	M81935/1-03L	ASM-3T	ASB-3T	.1900	.437	.337	1.562	.806	.300	.6250	.531	.980	.062	.268
M81935/1-04	M81935/1-04L	ASM-4T	ASB-4T	.2500	.437	.337	1.562	.806	.300	.6250	.531	.980	.062	.268
M81935/1-05	M81935/1-05L	ASM-5T	ASB-5T	.3125	.437	.327	1.875	.900	.360	.6875	.593	1.270	.062	.268
M81935/1-06	M81935/1-06L	ASM-6T	ASB-6T	.3750	.500	.416	1.938	1.025	.470	.8125	.687	1.235	.093	.319
M81935/1-07	M81935/1-07L	ASM-7T	ASB-7T	.4375	.562	.452	2.125	1.150	.540	.9062	.781	1.402	.093	.383
M81935/1-08	M81935/1-08L	ASM-8T	ASB-8T	.5000	.625	.515	2.438	1.337	.610	1.0000	.875	1.589	.093	.445
M81935/1-10	M81935/1-10L	ASM-10T	ASB-10T	.6250	.750	.577	2.625	1.525	.750	1.1875	1.062	1.683	.125	.541
M81935/1-12	M81935/1-12L	ASM-12T	ASB-12T	.7500	.875	.640	2.875	1.775	.850	1.3750	1.250	1.808	.125	.663
M81935/1-14	M81935/1-14L	ASM-14T	ASB-14T	.8750	.875	.765	3.375	2.025	1.000	1.6250	1.375	2.121	.156	.777
M81935/1-16	M81935/1-16L	ASM-16T	ASB-16T	1.0000	1.375	1.015	4.125	2.775	1.270	2.1250	1.875	2.464	.187	1.136

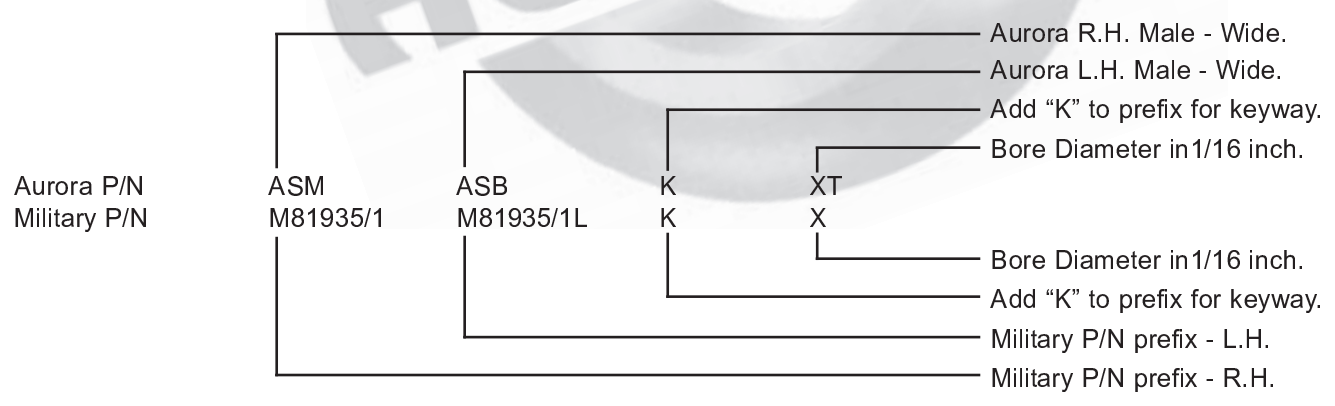



ASM-T & ASB-T Male Rod Ends
High Strength - Aerospace Series
SAE-AS81935/1

Specifications	
BODY	4340 Alloy Steel (AMS-S-5000) Heat Treated Cadmium Plated
BALL	440C Stainless Steel (AMS 5630) Heat Treated Hard Chrome Plated (AMS-QQ-C-320, Class 2)
RACE	17-4 PH Stainless Steel (AMS 5643) Heat Treated
LINER	AT 3200 Bearing Liner, Permanently Bonded to Race I.D. Qualified to SAE-AS81820

C ± .031	Thread UNJF-3A	a° Misalign. Angle Min.	Approx. Brg. Wt. Lbs.	Ult. Static Radial Load Lbs.	Fatigue Load Lbs.	Axial Proof Load Lbs.	No Load Rotational Breakaway Torque* In-Lbs.		AURORA NO.		MILITARY NO.	
							Min.	Max.	Right Hand	Left Hand	Right Hand	Left Hand
.968	5/16-24	15	.072	2,360	1,470	1,000	.5	6	ASM-3T	ASB-3T	M81935/1-03	M81935/1-03L
.968	5/16-24	15	.072	4,860	2,380	1,000	.5	6	ASM-4T	ASB-4T	M81935/1-04	M81935/1-04L
1.187	5/16-24	14	.087	7,180	2,770	1,100	1	15	ASM-5T	ASB-5T	M81935/1-05	M81935/1-05L
1.187	3/8-24	8	.136	8,550	3,570	1,660	1	15	ASM-6T	ASB-6T	M81935/1-06	M81935/1-06L
1.281	7/16-20	10	.183	12,000	4,800	1,850	1	15	ASM-7T	ASB-7T	M81935/1-07	M81935/1-07L
1.468	1/2-20	9	.278	19,500	7,680	2,040	1	15	ASM-8T	ASB-8T	M81935/1-08	M81935/1-08L
1.562	5/8-18	12	.424	21,900	9,180	2,430	1	15	ASM-10T	ASB-10T	M81935/1-10	M81935/1-10L
1.687	3/4-16	13	.639	29,300	11,600	2,810	1	15	ASM-12T	ASB-12T	M81935/1-12	M81935/1-12L
2.000	7/8-14	6	.963	34,500	13,100	3,320	1	24	ASM-14T	ASB-14T	M81935/1-14	M81935/1-14L
2.343	1 1/4-12	12	2.546	80,300	30,400	4,340	1	24	ASM-16T	ASB-16T	M81935/1-16	M81935/1-16L

Rod End Bearings listed in above tables are qualified for procurement under SAE-AS81935/1
 Stainless Steel bodies (not approved to military specs.) can be provided. Consult factory for
 materials substitutions or dimensional modification possibilities.

*No load rotational breakaway torque can be varied to meet specific application requirements.
 All threads are rolled and conform to UNJF-3A per MIL-S-8879.

AT 3200 Bearing Liner System is qualified for procurement under SAE-AS81820.

Operating temperature requirement per SAE-AS81820 is -65° to + 325° F (-54° to +163°C).

Wider temperature ranges are achievable.

Consult factory for additional information.



ASW-T & ASG-T Female Rod Ends
 High Strength - Aerospace Series
 SAE-AS81935/2

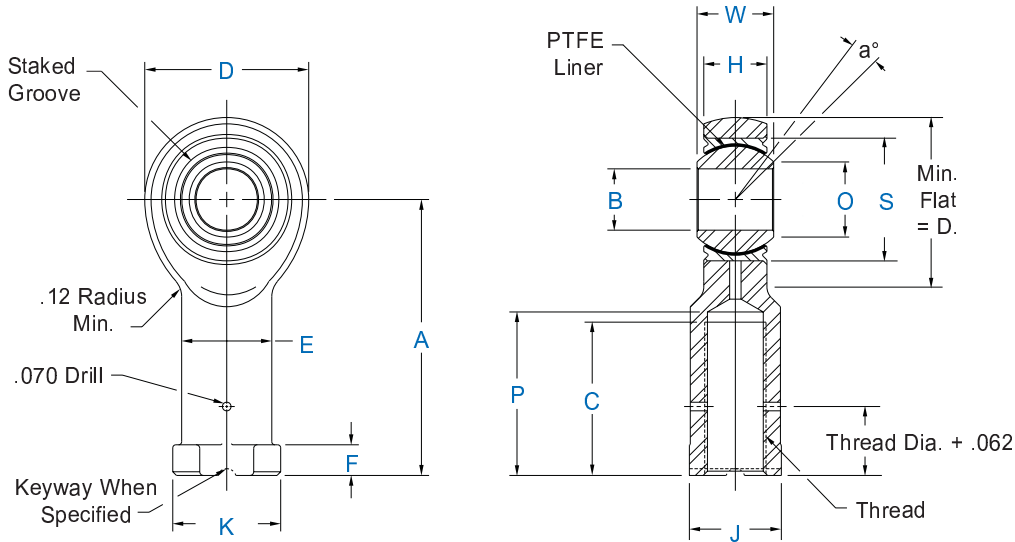

MILITARY NO.		AURORA NO.		DIMENSIONS IN INCHES											
Right Hand	Left Hand	Right Hand	Left Hand	B +.0000 -.0005	W +.000 -.002	H ± .005	A ± .010	D ± .010	O Min.	S Max. Housing I.D.	E ± .010	K Ref. Dia.	J +.002 -.010	F +.010 -.062	Ball Dia. Ref.
M81935/2-03	M81935/2-03L	ASW-3T	ASG-3T	.1900	.437	.337	1.375	.806	.300	.6250	.422	.500	.437	.188	.531
M81935/2-04	M81935/2-04L	ASW-4T	ASG-4T	.2500	.437	.337	1.469	.806	.300	.6250	.422	.500	.437	.188	.531
M81935/2-05	M81935/2-05L	ASW-5T	ASG-5T	.3125	.437	.327	1.625	.900	.360	.6875	.485	.580	.500	.250	.593
M81935/2-06	M81935/2-06L	ASW-6T	ASG-6T	.3750	.500	.416	1.812	1.025	.470	.8125	.547	.660	.562	.250	.687
M81935/2-07	M81935/2-07L	ASW-7T	ASG-7T	.4375	.562	.452	2.000	1.150	.540	.9062	.610	.720	.625	.250	.781
M81935/2-08	M81935/2-08L	ASW-8T	ASG-8T	.5000	.625	.515	2.250	1.337	.610	1.0000	.735	.880	.750	.250	.875
M81935/2-10	M81935/2-10L	ASW-10T	ASG-10T	.6250	.750	.577	2.500	1.525	.750	1.1875	.860	1.020	.875	.375	1.062
M81935/2-12	M81935/2-12L	ASW-12T	ASG-12T	.7500	.875	.640	2.875	1.775	.850	1.3750	.985	1.160	1.000	.375	1.250
M81935/2-14	M81935/2-14L	ASW-14T	ASG-14T	.8750	.875	.765	3.375	2.025	1.000	1.6250	1.110	1.300	1.125	.500	1.375
M81935/2-16	M81935/2-16L	ASW-16T	ASG-16T	1.0000	1.375	1.015	4.125	2.775	1.270	2.1250	1.688	2.020	1.750	.563	1.875

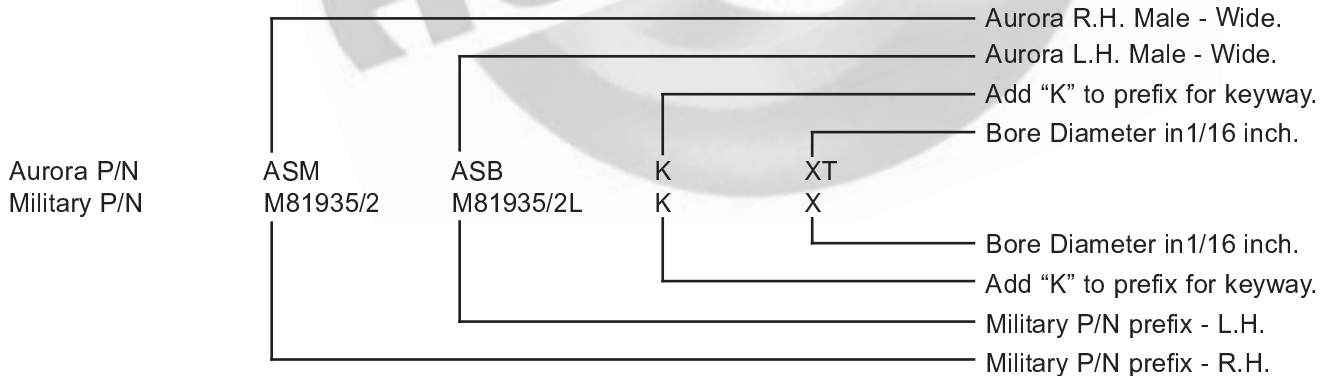



ASW-T & ASG-T Female Rod Ends
High Strength - Aerospace Series
SAE-AS81935/2

Specifications	
BODY	4340 Alloy Steel (AMS-S-5000) Heat Treated Cadmium Plated
BALL	440C Stainless Steel (AMS 5630) Heat Treated Hard Chrome Plated (AMS-QQ-C-320, Class 2)
RACE	17-4 PH Stainless Steel (AMS 5643) Heat Treated
LINER	AT 3200 Bearing Liner, Permanently Bonded to Race I.D. Qualified to SAE-AS81820

P Max.	C Min.	Thread UNJF-3B	a° Misalign. Angle Min.	Approx. Brg. Wt. Lbs.	Ult. Static Radial Load Lbs.	Fatigue Load Lbs.	Axial Proof Load Lbs.	No Load Rotational Breakaway Torque* In-Lbs.		AURORA NO.		MILITARY NO.	
								Min.	Max.	Right Hand	Left Hand	Right Hand	Left Hand
.875	.750	5/16-24	15	.080	2,360	1,470	1,000	.5	6	ASW-3T	ASG-3T	M81935/2-03	M81935/2-03L
.875	.750	5/16-24	15	.084	4,860	2,380	1,000	.5	6	ASW-4T	ASG-4T	M81935/2-04	M81935/2-04L
1.000	.875	3/8-24	14	.102	7,180	3,020	1,100	1	15	ASW-5T	ASG-5T	M81935/2-05	M81935/2-05L
1.125	1.000	3/8-24	8	.161	8,550	3,570	1,660	1	15	ASW-6T	ASG-6T	M81935/2-06	M81935/2-06L
1.250	1.125	7/16-20	10	.212	12,000	4,800	1,850	1	15	ASW-7T	ASG-7T	M81935/2-07	M81935/2-07L
1.375	1.250	1/2-20	9	.325	19,500	8,260	2,040	1	15	ASW-8T	ASG-8T	M81935/2-08	M81935/2-08L
1.500	1.375	5/8-18	12	.481	21,900	9,180	2,430	1	15	ASW-10T	ASG-10T	M81935/2-10	M81935/2-10L
1.750	1.625	3/4-16	13	.673	29,300	11,600	2,810	1	15	ASW-12T	ASG-12T	M81935/2-12	M81935/2-12L
2.062	1.875	7/8-14	6	.959	34,500	13,100	3,320	1	24	ASW-14T	ASG-14T	M81935/2-14	M81935/2-14L
2.312	2.125	1 1/4-12	12	2.717	80,300	30,400	4,340	1	24	ASW-16T	ASG-16T	M81935/2-16	M81935/2-16L

Rod End Bearings listed in above tables are qualified for procurement under SAE-AS81935/2
 Stainless Steel bodies (not approved to military specs.) can be provided. Consult factory for
 materials substitutions or dimensional modification possibilities.

*No load rotational breakaway torque can be varied to meet specific application requirements.
 All threads conform to UNJF-3B per MIL-S-8879.

AT 3200 Bearing Liner System is qualified for procurement under SAE-AS81820.
 Operating temperature requirement per SAE-AS81820 is -65° to + 325° F (-54° to +163°C).
 Wider temperature ranges are achievable.
 Consult factory for additional information.



ANC-TG & ANC-T Spherical Bearings

Narrow - Aerospace Series
SAE-AS14101 and SAE-AS14104

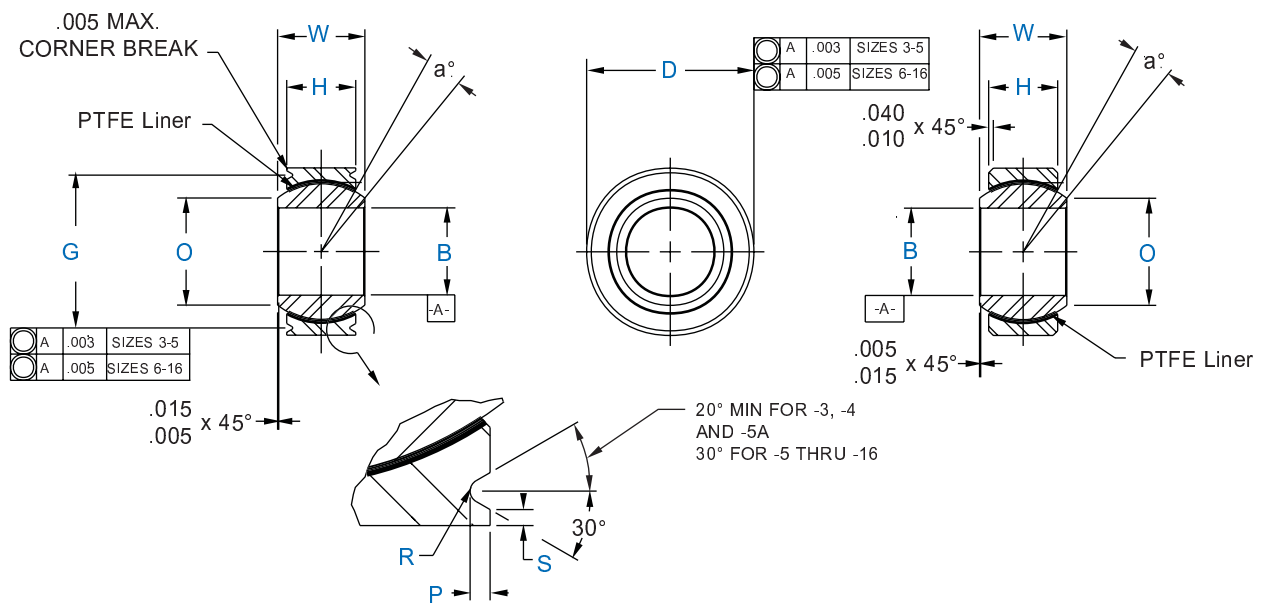

MILITARY NO.		AURORA NO.		DIMENSIONS IN INCHES										
GROOVED **	PLAIN	GROOVED **	PLAIN	B +.0000 -.0005	D +.0000 -.0005	W +.000 -.002	H ±.005	O Min.	P +.000 -.010	S Min.	G +.000 -.008	R _± +.002 -.005	Ball Dia. Ref.	a°
MS14101-3	MS14104-3	ANC-3TG	ANC-3T	.1900	.5625	.281	.218	.293	.025	.010	.500	.010	.406	10
MS14101-4	MS14104-4	ANC-4TG	ANC-4T	.2500	.6562	.343	.250	.364	.025	.010	.594	.010	.500	10
MS14101-5†	MS14104-5	ANC-5TG†	ANC-5T	.3125	.7500	.375	.281	.419	.035	.020	.650	.010	.562	10
MS14101-6	MS14104-6	ANC-6TG	ANC-6T	.3750	.8125	.406	.312	.475	.035	.020	.712	.015	.625	9
MS14101-7	MS14104-7	ANC-7TG	ANC-7T	.4375	.9062	.437	.343	.530	.035	.020	.806	.015	.687	8
MS14101-8	MS14104-8	ANC-8TG	ANC-8T	.5000	1.0000	.500	.390	.600	.055	.020	.876	.015	.781	8
MS14101-9	MS14104-9	ANC-9TG	ANC-9T	.5625	1.0937	.562	.437	.670	.055	.020	.970	.015	.875	8
MS14101-10	MS14104-10	ANC-10TG	ANC-10T	.6250	1.1875	.625	.500	.739	.055	.020	1.063	.015	.968	8
MS14101-12	MS14104-12	ANC-12TG	ANC-12T	.7500	1.4375	.750	.593	.920	.055	.020	1.313	.015	1.187	8
MS14101-14	MS14104-14	ANC-14TG	ANC-14T	.8750	1.5625	.875	.703	.980	.055	.020	1.438	.015	1.312	8
MS14101-16	MS14104-16	ANC-16TG	ANC-16T	1.0000	1.7500	1.000	.797	1.118	.055	.020	1.626	.015	1.500	9

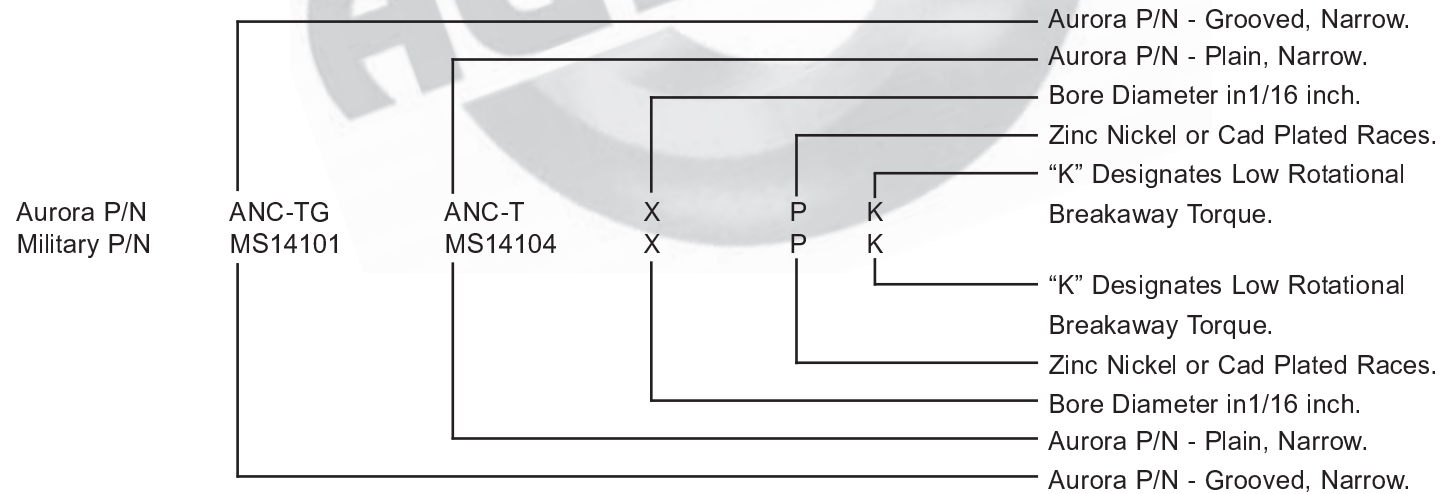



ANC-TG & ANC-T Spherical Bearings
Narrow - Aerospace Series
SAE-AS14101 and SAE-AS14104

Specifications	
BALL	440C Stainless Steel (AMS 5630) Heat Treated Hard Chrome Plated
RACE	17-4 PH Stainless Steel (AMS 5643) Heat Treated
LINER	AT 3200 Bearing Liner, Permanently Bonded to Race I.D. Qualified to SAE-AS81820



GROOVED SERIES



PLAIN SERIES

Bearing Fits

Radial Lbs.	Axial Lbs.	Oscillating Load Lbs.	Bearing Fits				Approx. Brg. Wt. Lbs.	AURORA NO.		MILITARY NO.	
			Standard Fit		"K" Fit			GROOVED **	PLAIN	GROOVED **	PLAIN
			No Load Rotational Breakaway Torque Max. In-Lbs.	No Load Rotational Breakaway Torque Max. In-Lbs.	Radial Clearance Max.	Axial Clearance Max.					
3,975	150	1,500	0.25 - 5.0	0.5	.0007	.0028	.020	ANC-3TG	ANC-3T	MS14101-3	MS14104-3
6,040	430	3,320	0.25 - 5.0	0.5	.0007	.0028	.020	ANC-4TG	ANC-4T	MS14101-4	MS14104-4
8,750	700	5,460	0.25 - 8.0	1.0	.0007	.0028	.030	ANC-5TG†	ANC-5T	MS14101-5†	MS14104-5
10,540	1,100	6,600	0.25 - 8.0	1.0	.0007	.0028	.040	ANC-6TG	ANC-6T	MS14101-6	MS14104-6
13,200	1,400	8,050	0.25 - 8.0	1.0	.0007	.0028	.050	ANC-7TG	ANC-7T	MS14101-7	MS14104-7
17,900	2,100	10,400	0.25 - 8.0	1.0	.0007	.0028	.070	ANC-8TG	ANC-8T	MS14101-8	MS14104-8
23,200	3,680	13,000	0.25 - 8.0	1.0	.0007	.0028	.090	ANC-9TG	ANC-9T	MS14101-9	MS14104-9
30,500	4,720	16,450	0.25 - 8.0	1.0	.0007	.0028	.120	ANC-10TG	ANC-10T	MS14101-10	MS14104-10
46,400	6,750	23,600	0.25 - 8.0	1.0	.0007	.0028	.210	ANC-12TG	ANC-12T	MS14101-12	MS14104-12
62,200	9,350	30,250	0.25 - 12.0	2.0	.0010	.0040	.270	ANC-14TG	ANC-14T	MS14101-14	MS14104-14
82,200	12,160	38,000	0.25 - 12.0	2.0	.0010	.0040	.390	ANC-16TG	ANC-16T	MS14101-16	MS14104-16

Bearings listed in above tables are qualified for procurement under SAE-AS14101 and SAE-AS14104.

"K" Type Low Torque Bearing fit requirements are listed above. Other variations of torque requirements can be varied to meet specific application requirements.

AT 3200 Bearing Liner System is qualified for procurement under SAE-AS81820.

Operating temperature requirement per SAE-AS81820 is -65° to + 325° F (-54° to +163°C).

Wider temperature ranges are achievable.

*Standard fit bearings are void of any "radial" or "axial" clearance.

**For further staking groove and assembly information, see pages 33 and 34

Consult factory for additional information.

†-5A is identical to -5 except "G" dimension is .660

‡+.000, -.005 for -3, -4, -5A.



AWC-TG & AWC-T Spherical Bearings

Wide - Aerospace Series

SAE-AS14102 and SAE-AS14103

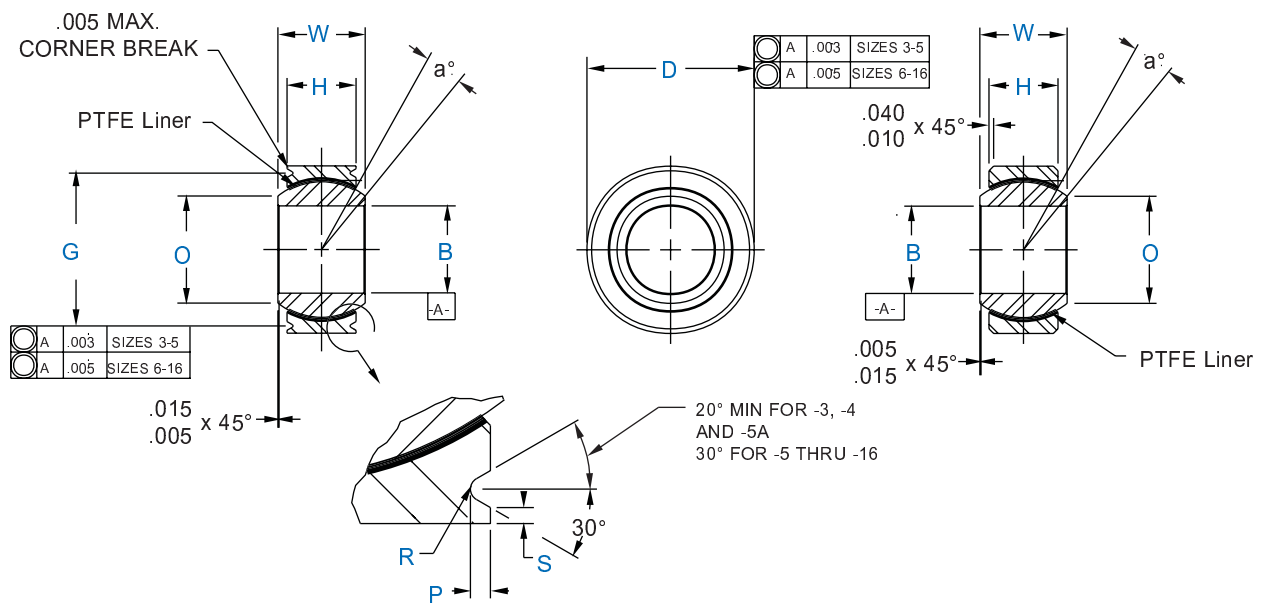

MILITARY NO.		AURORA NO.		DIMENSIONS IN INCHES										
GROOVED **	PLAIN	GROOVED **	PLAIN	B +.0000 -.0005	D +.0000 -.0005	W +.000 -.002	H ± .005	O Min.	P +.000 -.010	S Min.	G +.000 -.008	R +.002 -.005	Ball Dia. Ref.	a°
MS14103-3	MS14102-3	AWC-3TG	AWC-3T	.1900	.6250	.437	.327	.300	.025	.010	.563	.010	.531	15
MS14103-4	MS14102-4	AWC-4TG	AWC-4T	.2500	.6250	.437	.327	.300	.025	.010	.563	.010	.531	15
MS14103-5	MS14102-5	AWC-5TG	AWC-5T	.3125	.6875	.437	.317	.360	.025	.010	.625	.010	.593	14
MS14103-6	MS14102-6	AWC-6TG	AWC-6T	.3750	.8125	.500	.406	.466	.035	.020	.712	.015	.687	8
MS14103-7†	MS14102-7	AWC-7TG†	AWC-7T	.4375	.9375	.562	.442	.537	.035	.020	.837	.015	.781	10
MS14103-8	MS14102-8	AWC-8TG	AWC-8T	.5000	1.0000	.625	.505	.607	.035	.020	.900	.015	.875	9
MS14103-9	MS14102-9	AWC-9TG	AWC-9T	.5625	1.1250	.687	.536	.721	.035	.020	1.025	.015	1.000	10
MS14103-10	MS14102-10	AWC-10TG	AWC-10T	.6250	1.1875	.750	.567	.747	.035	.020	1.087	.015	1.062	12
MS14103-12	MS14102-12	AWC-12TG	AWC-12T	.7500	1.3750	.875	.630	.845	.055	.020	1.251	.015	1.250	13
MS14103-14	MS14102-14	AWC-14TG	AWC-14T	.8750	1.6250	.875	.755	.995	.055	.020	1.501	.015	1.375	6
MS14103-16	MS14102-16	AWC-16TG	AWC-16T	1.0000	2.1250	1.375	1.005	1.269	.055	.020	2.001	.015	1.875	12

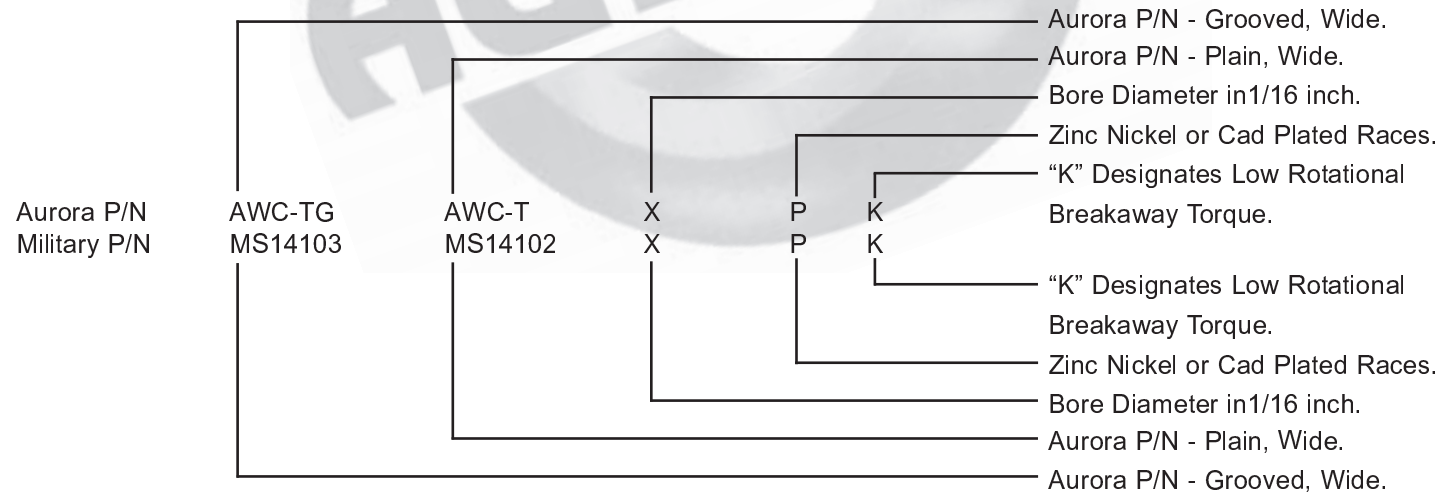



AWC-TG & AWC-T Spherical Bearings
Wide - Aerospace Series
SAE-AS14102 and SAE-AS14103

Specifications	
BALL	440C Stainless Steel (AMS 5630) Heat Treated Hard Chrome Plated
RACE	17-4 PH Stainless Steel (AMS 5643) Heat Treated
LINER	AT 3200 Bearing Liner, Permanently Bonded to Race I.D. Qualified to SAE-AS81820



GROOVED SERIES



PLAIN SERIES

Bearing Fits

Radial Lbs.	Axial Lbs.	Oscillating Load Lbs.	Standard Fit				Approx. Brg. Wt. Lbs.	AURORA NO.		MILITARY NO.	
			No Load Rotational Breakaway Torque Max. In-Lbs.	No Load Rotational Breakaway Torque Max. In-Lbs.	Radial Clearance Max.	Axial Clearance Max.		GROOVED **	PLAIN	GROOVED **	PLAIN
2,500	1,770	4,900	0.25 - 5.0	0.5	.0007	.0021	.031	AWC-3TG	AWC-3T	MS14103-3	MS14102-3
5,500	1,770	4,900	0.25 - 5.0	0.5	.0007	.0021	.031	AWC-4TG	AWC-4T	MS14103-4	MS14102-4
9,400	1,640	6,050	0.25 - 8.0	1.0	.0007	.0021	.035	AWC-5TG	AWC-5T	MS14103-5	MS14102-5
13,700	2,630	8,310	0.25 - 8.0	1.0	.0007	.0021	.060	AWC-6TG	AWC-6T	MS14103-6	MS14102-6
20,700	3,650	11,750	0.25 - 8.0	1.0	.0007	.0021	.080	AWC-7TG†	AWC-7T	MS14103-7†	MS14102-7
21,400	4,970	14,950	0.25 - 8.0	1.0	.0007	.0021	.100	AWC-8TG	AWC-8T	MS14103-8	MS14102-8
26,600	5,370	18,100	0.25 - 8.0	1.0	.0007	.0021	.135	AWC-9TG	AWC-9T	MS14103-9	MS14102-9
29,000	6,130	20,250	0.25 - 8.0	1.0	.0007	.0021	.160	AWC-10TG	AWC-10T	MS14103-10	MS14102-10
37,000	7,730	26,200	0.25 - 8.0	1.0	.0007	.0021	.240	AWC-12TG	AWC-12T	MS14103-12	MS14102-12
65,200	10,800	33,600	0.25 - 12.0	2.0	.0010	.0030	.350	AWC-14TG	AWC-14T	MS14103-14	MS14102-14
104,000	19,300	56,250	0.25 - 12.0	2.0	.0010	.0030	.970	AWC-16TG	AWC-16T	MS14103-16	MS14102-16

Bearings listed in above tables are qualified for procurement under SAE-AS14102 and SAE-AS14103. "K" Type Low Torque Bearing fit requirements are listed above. Other variations of torque requirements can be varied to meet specific application requirements.

AT 3200 Bearing Liner System is qualified for procurement under SAE-AS81820. Operating temperature requirement per SAE-AS81820 is -65° to + 325° F (-54° to +163°C). Wider temperature ranges are achievable.

*Standard fit bearings are void of any "radial" or "axial" clearance.
 **For further staking groove and assembly information, see pages 32 and 33

Consult factory for additional information.
 †-7A is identical to -7 except "G" dimension is .660



AJB-TFA/ - TFC
Flanged Journal Bushings
SAE-AS81934/2

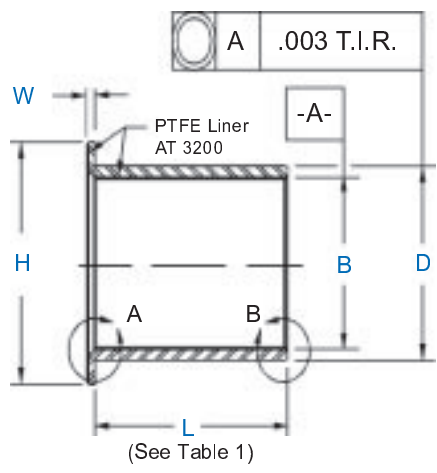

Specifications	
"A"	Aluminum Alloy QQ-A-200/3 or QQ-A-225/6 (2024T851 or 2024T8511), Chemical Film Treatment per MIL-C-5541
"C"	Corrosion Resistant Steel, AMS 5643 (17-4 PH) Condition H-1150 per MIL-H-6875, Passivated per QQ-P-35 (Cad, or Zinc-Nickel plate optional).
"T"	AT 3200 Bearing Liner System, Permanently Bonded to Bushing I.D. Qualified to SAE-AS81820

BUSHING NO.		DIMENSIONS IN INCHES					Weight* Lbs./Inch (Ref) L-1.00		Flange Weight Lbs. (Ref)	
Aluminum	Stainless Steel	B +.0000 -.0010	D		H +.000 -.020	W +.000 -.005	Alum.	CRES	Alum.	CRES
			+.0005	+.0000 -.0005						
AJB-4TFA	AJB-4TFC	.2515	.3760		.750	.0625	.006	.016	.002	.006
AJB-5TFA	AJB-5TFC	.3140	.4386		.812	.0625	.007	.019	.003	.007
AJB-6TFA	AJB-6TFC	.3765	.5012		.875	.0625	.008	.022	.003	.007
AJB-7TFA	AJB-7TFC	.4390	.5638		.937	.0625	.009	.025	.003	.008
AJB-7TFA-1	AJB-7TFC-1	.4390	.5638		.745	.0625	.009	.025	.003	.008
AJB-8TFA	AJB-8TFC	.5015	.6265		1.000	.0625	.011	.028	.003	.009
AJB-9TFA	AJB-9TFC	.5640	.6892		1.125	.0625	.012	.031	.004	.011
AJB-10TFA	AJB-10TFC	.6265	.8142		1.250	.0625	.021	.056	.005	.014
AJB-11TFA	AJB-11TFC	.6890	.8767		1.375	.0625	.022	.060	.006	.016
AJB-12TFA	AJB-12TFC	.7515	.9393		1.500	.0625	.024	.065	.007	.020
AJB-14TFA	AJB-14TFC	.8765	1.0645		1.625	.0625	.028	.075	.008	.022
AJB-16TFA	AJB-16TFC	1.0015	1.1898		1.750	.0625	.031	.084	.009	.024
AJB-18TFA	AJB-18TFC	1.1265	1.3148		1.875	.0937	.035	.094	.015	.041
AJB-20TFA	AJB-20TFC	1.2515	1.4398		2.000	.0937	.038	.103	.016	.045
AJB-22TFA	AJB-22TFC	1.3765	1.5648		2.125	.0937	.041	.113	.017	.048
AJB-24TFA	AJB-24TFC	1.5015	1.7523		2.250	.0937	.062	.171	.018	.051
AJB-26TFA	AJB-26TFC	1.6265	1.8773		2.375	.0937	.067	.183	.020	.055
AJB-28TFA	AJB-28TFC	1.7515	2.0023		2.500	.0937	.071	.193	.021	.058
AJB-32TFA	AJB-32TFC	2.0015	2.2523		2.750	.0937	.081	.222	.023	.065

Example of weight calculation: AJB-16TF-016
 Sleeve weight: (0.31 lb/in) x .500 = .0155 lbs
 Flange weight = .009 lbs
 Total weight = .0245 lbs

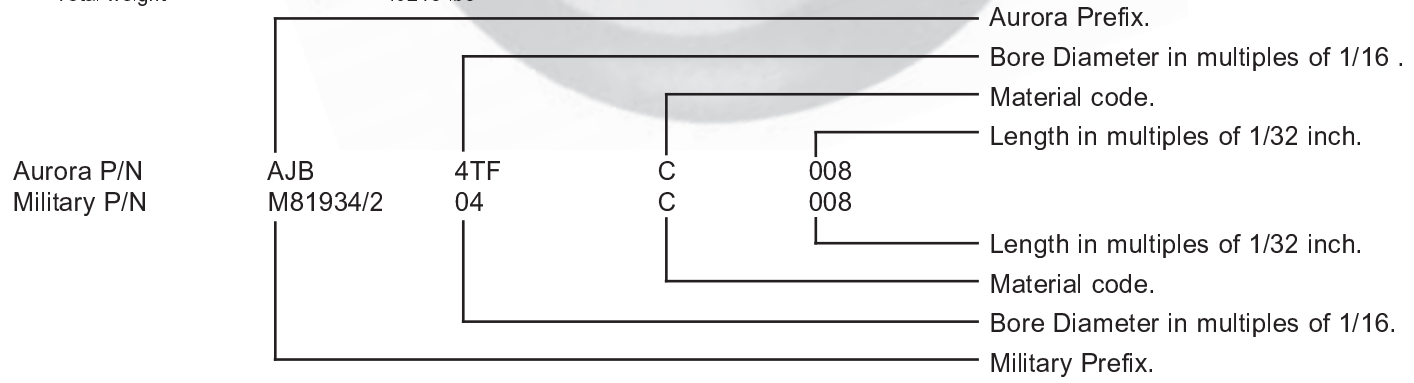



AJB-TFA/ - TFC Flanged Journal Bushings SAE-AS81934/2

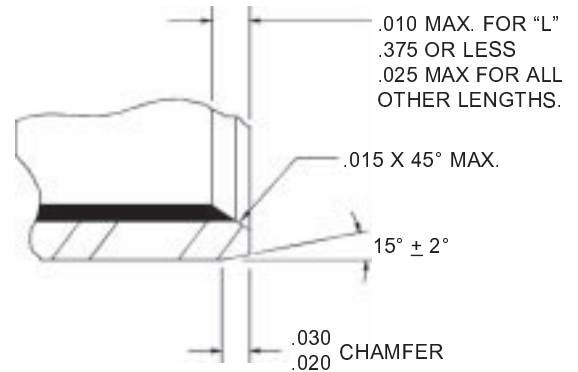
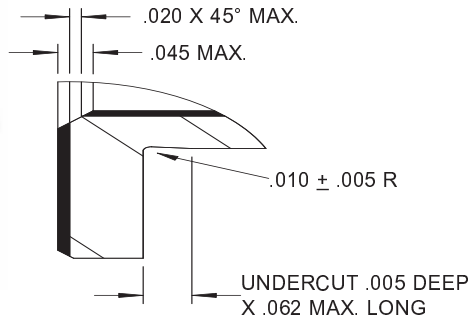

TABLE 1A

DETAIL A

DETAIL B

DASH NO.	NOMINAL SIZE	Length L ^{+0.000} / _{-.010}															
		.156	.187	.218	.250	.281	.312	.343	.375	.437	.500	.562	.625	.687	.750	.875	
-04	1/4	005	006	007	008	009	010	011	012	014							
-05	5/16	005	006	007	008	009	010	011	012	014	016	018					
-06	3/8	005	006	007	008	009	010	011	012	014	016	018	020	022			
-07	7/16	005	006	007	008	009	010	011	012	014	016	018	020	022	024	028	
-08	1/2	005	006	007	008	009	010	011	012	014	016	018	020	022	024	028	
-09	9/16	005	006	007	008	009	010	011	012	014	016	018	020	022	024	028	
-10	5/8	005	006	007	008	009	010	011	012	014	016	018	020	022	024	028	
-11	11/16				008	009	010	011	012	014	016	018	020	022	024	028	
-12	3/4				008	009	010	011	012	014	016	018	020	022	024	028	
-14	7/8				008	009	010	011	012	014	016	018	020	022	024	028	
-16	1				008	009	010	011	012	014	016	018	020	022	024	028	
-18	1 1/8						010	011	012	014	016	018	020	022	024	028	
-20	1 1/4								012	014	016	018	020	022	024	028	
-22	1 3/8								012	014	016	018	020	022	024	028	
-24	1 1/2								012	014	016	018	020	022	024	028	
-26	1 5/8										016	018	020	022	024	028	
-28	1 3/4										016	018	020	022	024	028	
-32	2										016	018	020	022	024	028	

TABLE 1B

DASH NO.	NOMINAL SIZE	Length L ^{+0.000} / _{-.010}															
		1.000	1.125	1.250	1.375	1.500	1.625	1.750	1.875	2.000	2.125	2.250	2.375	2.500	2.750	3.000	
-04	1/4																
-05	5/16																
-06	3/8																
-07	7/16																
-08	1/2																
-09	9/16	032	036														
-10	5/8	032	036	040	044												
-11	11/16	032	036	040	044	048	052										
-12	3/4	032	036	040	044	048	052										
-14	7/8	032	036	040	044	048	052										
-16	1	032	036	040	044	048	052	056	060								
-18	1 1/8	032	036	040	044	048	052	056	060								
-20	1 1/4	032	036	040	044	048	052	056	060	064	068						
-22	1 3/8	032	036	040	044	048	052	056	060	064	068						
-24	1 1/2	032	036	040	044	048	052	056	060	064	068	072	076	080	088		
-26	1 5/8	032	036	040	044	048	052	056	060	064	068	072	076	080	088	096	
-28	1 3/4	032	036	040	044	048	052	056	060	064	068	072	076	080	088	096	
-32	2	032	036	040	044	048	052	056	060	064	068	072	076	080	088	096	



AJB-TA/ - TC Journal Bushings SAE-AS81934/1

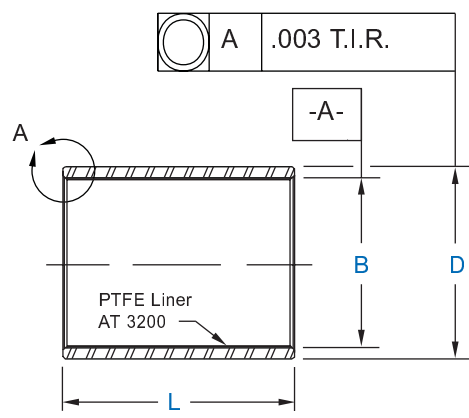

(See Table 2)

Specifications	
"A"	Aluminum Alloy QQ-A-200/3 or QQ-A-225/6 (2024T851 or 2024T8511), Chemical Film Treatment per MIL-C-5541
"C"	Corrosion Resistant Steel, AMS 5643 (17-4 PH) Condition H-1150 per MIL-H-6875, Passivated per QQ-P-35 (Cad, or Zinc-Nickel plate optional).
"T"	AT 3200 Bearing Liner System, Permanently Bonded to Bushing I.D. Qualified to SAE-AS81820

BUSHING NO.		DIMENSIONS IN INCHES			Weight*	
Aluminum	Stainless Steel	B +.0000 -.0010	D		Lbs./Inch (Ref) L-1.00	
			± .0005 Alum.	D +.0000 -.0005 CRES	Alum.	CRES
AJB-4TA	AJB-4TC	.2515	.3760		.006	.016
AJB-5TA	AJB-5TC	.3140	.4386		.007	.019
AJB-6TA	AJB-6TC	.3765	.5012		.008	.022
AJB-7TA	AJB-7TC	.4390	.5638		.009	.025
AJB-8TA	AJB-8TC	.5015	.6265		.011	.028
AJB-9TA	AJB-9TC	.5640	.6892		.012	.031
AJB-10TA	AJB-10TC	.6265	.8142		.021	.056
AJB-11TA	AJB-11TC	.6890	.8767		.022	.060
AJB-12TA	AJB-12TC	.7515	.9393		.024	.065
AJB-14TA	AJB-14TC	.8765	1.0645		.028	.075
AJB-16TA	AJB-16TC	1.0015	1.1898		.031	.084
AJB-18TA	AJB-18TC	1.1265	1.3148		.035	.094
AJB-20TA	AJB-20TC	1.2515	1.4398		.038	.103
AJB-22TA	AJB-22TC	1.3765	1.5648		.041	.113
AJB-24TA	AJB-24TC	1.5015	1.7523		.062	.171
AJB-26TA	AJB-26TC	1.6265	1.8773		.067	.183
AJB-28TA	AJB-28TC	1.7515	2.0023		.071	.193
AJB-32TA	AJB-32TC	2.0015	2.2523		.081	.222

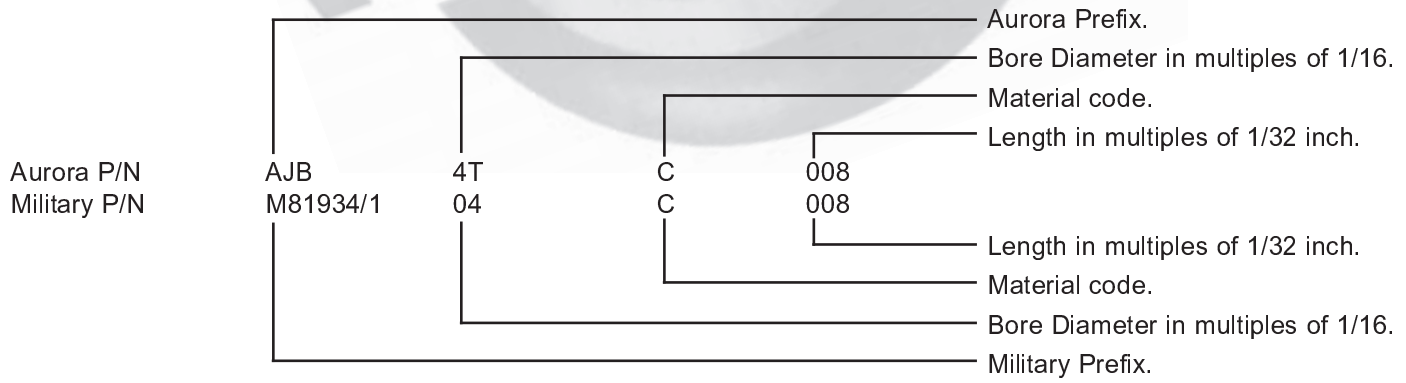



AJB-TA/ - TC Straight Journal Bushings
SAE-AS81934/1

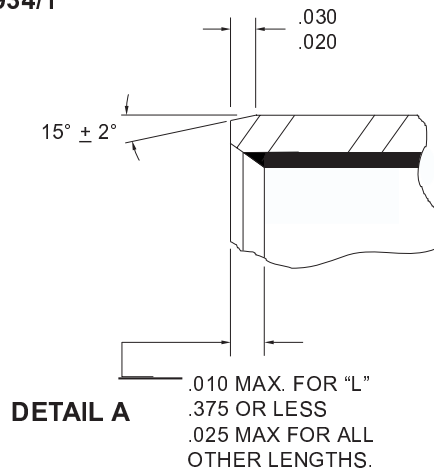

TABLE 2A

DASH NO.	NOMINAL SIZE	Length L ^{+0.000} / _{-0.010}														
		.156	.187	.218	.250	.281	.312	.343	.375	.437	.500	.562	.625	.687	.750	.875
-04	1/4	005	006	007	008	009	010	011	012	014						
-05	5/16	005	006	007	008	009	010	011	012	014	016	018				
-06	3/8	005	006	007	008	009	010	011	012	014	016	018	020	022		
-07	7/16	005	006	007	008	009	010	011	012	014	016	018	020	022	024	028
-08	1/2	005	006	007	008	009	010	011	012	014	016	018	020	022	024	028
-09	9/16	005	006	007	008	009	010	011	012	014	016	018	020	022	024	028
-10	5/8	005	006	007	008	009	010	011	012	014	016	018	020	022	024	028
-11	11/16				008	009	010	011	012	014	016	018	020	022	024	028
-12	3/4				008	009	010	011	012	014	016	018	020	022	024	028
-14	7/8				008	009	010	011	012	014	016	018	020	022	024	028
-16	1				008	009	010	011	012	014	016	018	020	022	024	028
-18	1 1/8						010	011	012	014	016	018	020	022	024	028
-20	1 1/4								012	014	016	018	020	022	024	028
-22	1 3/8								012	014	016	018	020	022	024	028
-24	1 1/2								012	014	016	018	020	022	024	028
-26	1 5/8										016	018	020	022	024	028
-28	1 3/4										016	018	020	022	024	028
-32	2										016	018	020	022	024	028

TABLE 2B

DASH NO.	NOMINAL SIZE	Length L ^{+0.000} / _{-0.010}														
		1.000	1.125	1.250	1.375	1.500	1.625	1.750	1.875	2.000	2.125	2.250	2.375	2.500	2.750	3.000
-04	1/4															
-05	5/16															
-06	3/8															
-07	7/16															
-08	1/2															
-09	9/16	032	036													
-10	5/8	032	036	040	044											
-11	11/16	032	036	040	044	048	052									
-12	3/4	032	036	040	044	048	052									
-14	7/8	032	036	040	044	048	052									
-16	1	032	036	040	044	048	052	056	060							
-18	1 1/8	032	036	040	044	048	052	056	060							
-20	1 1/4	032	036	040	044	048	052	056	060	064	068					
-22	1 3/8	032	036	040	044	048	052	056	060	064	068					
-24	1 1/2	032	036	040	044	048	052	056	060	064	068	072	076	080	088	
-26	1 5/8	032	036	040	044	048	052	056	060	064	068	072	076	080	088	096
-28	1 3/4	032	036	040	044	048	052	056	060	064	068	072	076	080	088	096
-32	2	032	036	040	044	048	052	056	060	064	068	072	076	080	088	096



ASM & ASB Male Rod Ends
High Strength - Aerospace Series
Metal to Metal

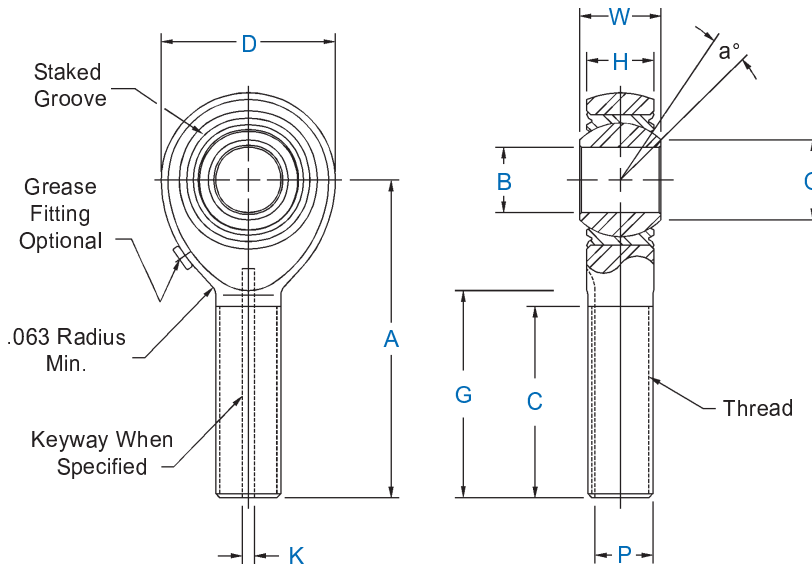

SECTION TWO

Rod End No.		DIMENSIONS IN INCHES											a°	Ult.	Approx.	
Right Hand	Left Hand	B + .0000 - .0005	W + .000 - .002	H ± .005	A ± .010	D ± .010	O Min.	Ball Dia. Ref.	G + .000 - .020	K + .005 - .000	P + .000 - .010	C ± .031	Thread UNJF-3A	Misalign. Angle Min.	Static Radial Load Lbs	Brg. Wt. Lbs.
ASM-3	ASB-3	.1900	.437	.337	1.562	.806	.300	.531	.980	.062	.268	.968	5/16-24	15	2,360	.072
ASM-4	ASB-4	.2500	.437	.337	1.562	.806	.300	.531	.980	.062	.268	.968	5/16-24	15	4,860	.072
ASM-5	ASB-5	.3125	.437	.327	1.875	.900	.360	.593	1.270	.062	.268	1.187	5/16-24	14	7,180	.087
ASM-6	ASB-6	.3750	.500	.416	1.938	1.025	.470	.687	1.235	.093	.319	1.187	3/8-24	8	8,550	.136
ASM-7	ASB-7	.4375	.562	.452	2.125	1.150	.540	.781	1.402	.093	.383	1.281	7/16-20	10	12,000	.183
ASM-8	ASB-8	.5000	.625	.515	2.438	1.337	.610	.875	1.589	.093	.445	1.468	1/2-20	9	19,500	.278
ASM-10	ASB-10	.6250	.750	.577	2.625	1.525	.750	1.062	1.683	.125	.541	1.562	5/8-18	12	21,900	.424
ASM-12	ASB-12	.7500	.875	.640	2.875	1.775	.850	1.250	1.808	.125	.663	1.687	3/4-16	13	29,300	.639
ASM-14	ASB-14	.8750	.875	.765	3.375	2.025	1.000	1.375	2.121	.156	.777	2.000	7/8-14	6	34,500	.963
ASM-16	ASB-16	1.0000	1.375	1.015	4.125	2.775	1.270	1.875	2.464	.187	1.136	2.343	1 1/4-12	12	80,000	2.546

Specifications	
BODY	4340 Alloy Steel (AMS-S-5000) Heat Treated Cadmium Plated
BALL	440C Stainless Steel (AMS 5630) Heat Treated Hard Chrome Plated (AMS-QQ-C-320, Class 2)
RACE	17-4 PH Stainless Steel (AMS 5643) Heat Treated

The metal to metal Rod End Bearings listed in above tables have the same envelop dimensions, materials (less PTFE Liners), basic tolerances, and load capacities as those that are approved to SAE-AS81935/1.

Consult factory for material substitutions or dimensional modification possibilities.

Radial Clearance is .002 max (for .0005 max, use suffix-R Example: ASMK-6R).

Add Letter "K" to prefix to designate keyway (Example: ASMK-6).

Add letters "F" or "Z" to part size to designate flush or zerk type fittings respectively (Example ASM-6F or ASM-6Z).

All threads are rolled and conform to MIL-S-8879.

For dry-film lubrication on the I.D. of races, use suffix D(Example ASMK-6D). For dry film on ball bore and/or O.D. contact factory.



ASW & ASG Female Rod Ends High Strength - Aerospace Series Metal to Metal

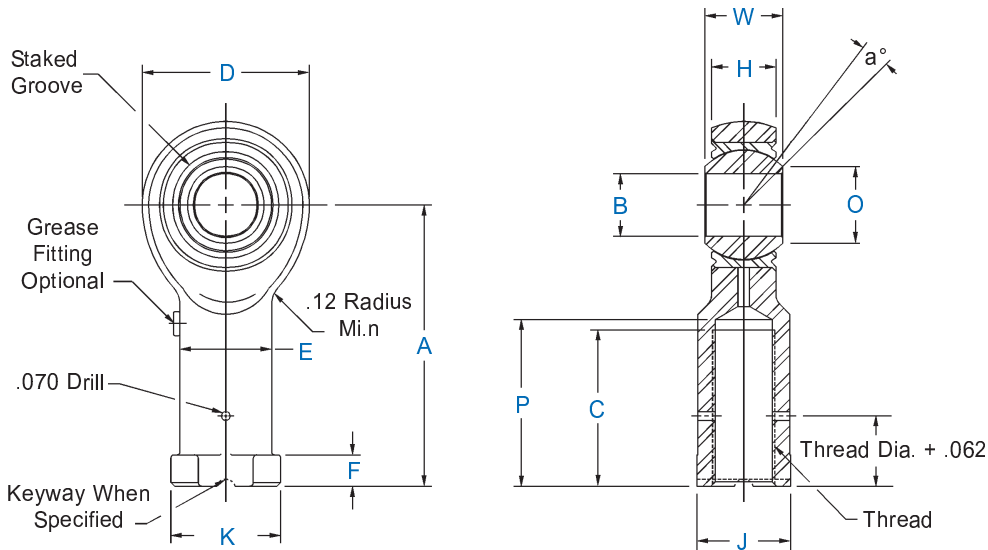

SECTION TWO

Rod End No.		DIMENSIONS IN INCHES														a°	Ult.	Approx.
Right Hand	Left Hand	B +.0000 -.0005	W +.000 -.002	H ± .005	A ± .010	D ± .010	O Min.	E ± .010	K Ref. Dia.	J +.002 -.010	F +.010 -.062	Ball Dia Ref.	P Max.	C Min.	Thread UNJF-3B	Misalign. Angle Min.	Static Radial Load Lbs.	Brg. Wt. Lbs.
ASW3	ASG-3	.1900	.437	.337	1.375	.806	.300	.422	.500	.437	.188	.531	.875	.750	5/16-24	15	2,360	.080
ASW-4	ASG-4	.2500	.437	.337	1.469	.806	.300	.422	.500	.437	.188	.531	.875	.750	5/16-24	15	4,860	.084
ASW-5	ASG-5	.3125	.437	.327	1.625	.900	.360	.485	.580	.500	.250	.593	1.000	.875	3/8-24	14	7,180	.102
ASW-6	ASG-6	.3750	.500	.416	1.812	1.025	.470	.547	.660	.562	.250	.687	1.125	1.000	3/8-24	8	8,550	.161
ASW-7	ASG-7	.4375	.562	.452	2.000	1.150	.540	.610	.720	.625	.250	.781	1.250	1.125	7/16-20	10	12,000	.212
ASW-8	ASG-8	.5000	.625	.515	2.250	1.337	.610	.735	.880	.750	.250	.875	1.375	1.250	1/2-20	9	19,500	.325
ASW-10	ASG-10	.6250	.750	.577	2.500	1.525	.750	.860	1.020	.875	.375	1.062	1.500	1.375	5/8-18	12	21,900	.481
ASW-12	ASG-12	.7500	.875	.640	2.875	1.775	.850	.985	1.160	1.000	.375	1.250	1.750	1.625	3/4-16	13	29,300	.673
ASW-14	ASG-14	.8750	.875	.765	3.375	2.025	1.000	1.110	1.300	1.125	.500	1.375	2.062	1.875	7/8-14	6	34,500	.959
ASW-16	ASG-16	1.0000	1.375	1.015	4.125	2.775	1.270	1.688	2.020	1.750	.563	1.875	2.312	2.125	1 1/4-12	12	80,300	2.717

Specifications	
BODY	4340 Alloy Steel (AMS-S-5000) Heat Treated Cadmium Plated
BALL	440C Stainless Steel (AMS 5630) Heat Treated Hard Chrome Plated (AMS-QQ-C-320 Class 2)
RACE	17-4 PH Stainless Steel (AMS 5643) Heat Treated

The metal to metal Rod End Bearings listed in above tables have the same envelop dimensions, materials (less PTFE Liners), basic tolerances, and load capacities as those that are approved to SAE-AS81935/2.

Consult factory for material substitutions or dimensional modification possibilities.

Radial Clearance is .002 max (for .0005 max, use suffix-R Example: ASMK-6R).

Add Letter "K" to prefix to designate keyway (Example: ASWK-6).

Add letters "F" or "Z" to part size to designate flush or zerk type fittings respectively (Example ASM-6F or ASW-6Z).

All threads conform to UNJF-3B per MIL-S-8879.

For dry-film lubrication on the I.D. of races, use suffix D(Example ASWK-6D). For dry film on ball bore and/or O.D. contact factory.



NC-G & NC Spherical Bearings

Narrow - Aerospace Series Metal to Metal

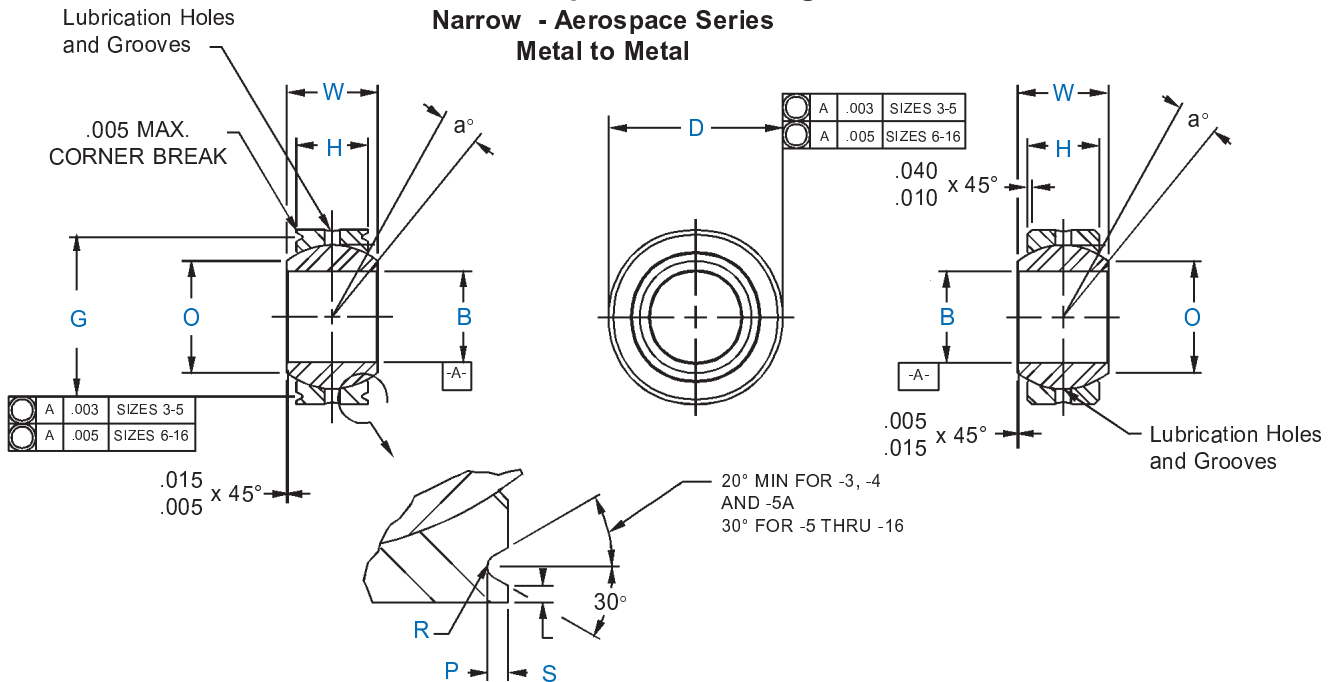

SECTION TWO

Rod End No.		DIMENSIONS IN INCHES											Static Limit Load		Approx. Brg. Wt. Lbs.
Grooved	Plain	B	D	W	H	O	P*	S	G	R	Ball Dia. Ref.	a°	Radial Lbs.	Axial Lbs.	
NC-3G	NC-3	.1900 +.0000 -.0005	.5625 +.0000 -.0005	.281 +.000 -.002	.218 ±.005	.293 Min.	.025 +.000 -.010	.010 Min.	.500 +.000 -.008	.010 +.002 -.005	.406 Ref.	10	3,975	150	.020
NC-4G	NC-4	.2500	.6562	.343	.250	.364	.025	.010	.594	.010	.500	10	6,040	430	.020
NC-5G	NC-5	.3125	.7500	.375	.281	.419	.035	.020	.650	.010	.562	10	8,750	700	.030
NC-6G	NC-6	.3750	.8125	.406	.312	.475	.035	.020	.712	.015	.625	9	10,540	1,100	.040
NC-7G	NC-7	.4375	.9062	.437	.343	.530	.035	.020	.806	.015	.687	8	13,200	1,400	.050
NC-8G	NC-8	.5000	1.0000	.500	.390	.600	.055	.020	.876	.015	.781	8	17,900	2,100	.070
NC-9G	NC-9	.5625	1.0937	.562	.437	.670	.055	.020	.970	.015	.875	8	23,200	3,680	.090
NC-10G	NC-10	.6250	1.1875	.625	.500	.739	.055	.020	1.063	.015	.968	8	30,500	4,720	.120
NC-12G	NC-12	.7500	1.4375	.750	.593	.920	.055	.020	1.313	.015	1.187	8	46,400	6,750	.210
NC-14G	NC-14	.8750	1.5625	.875	.703	.980	.055	.020	1.438	.015	1.312	8	62,200	9,350	.270
NC-16G	NC-16	1.0000	1.7500	1.000	.797	1.118	.055	.020	1.626	.015	1.500	9	82,200	12,160	.390

Specifications	
BALL	440C Stainless Steel (AMS 5630) Heat Treated Hard Chrome Plated (AMS-QQ-C-320, Class 2)
RACE	17-4 PH Stainless Steel (AMS 5643) Heat Treated

The metal to metal Spherical Bearing listed in above tables have the same envelope dimensions, materials (less PTFE), basic tolerances (except fit-up), as those that are approved to SAE-AS14101 and SAE-AS14104.

Consult factory for material substitutions or dimensional modification possibilities.

Radial Clearance is .002 max. (for .0005 max., use suffix-R ex: NC-6R).

For dry-film lubrication on the I.D. of races, use suffix D (ex: NC-6D). For dry-film on ball bore and/or ball O.D. contact factory.

*For further staking groove and assembly information, see pages 31-33.

Consult factory for additional information.



WC-G & WC Spherical Bearings
Wide - Aerospace Series
Metal to Metal

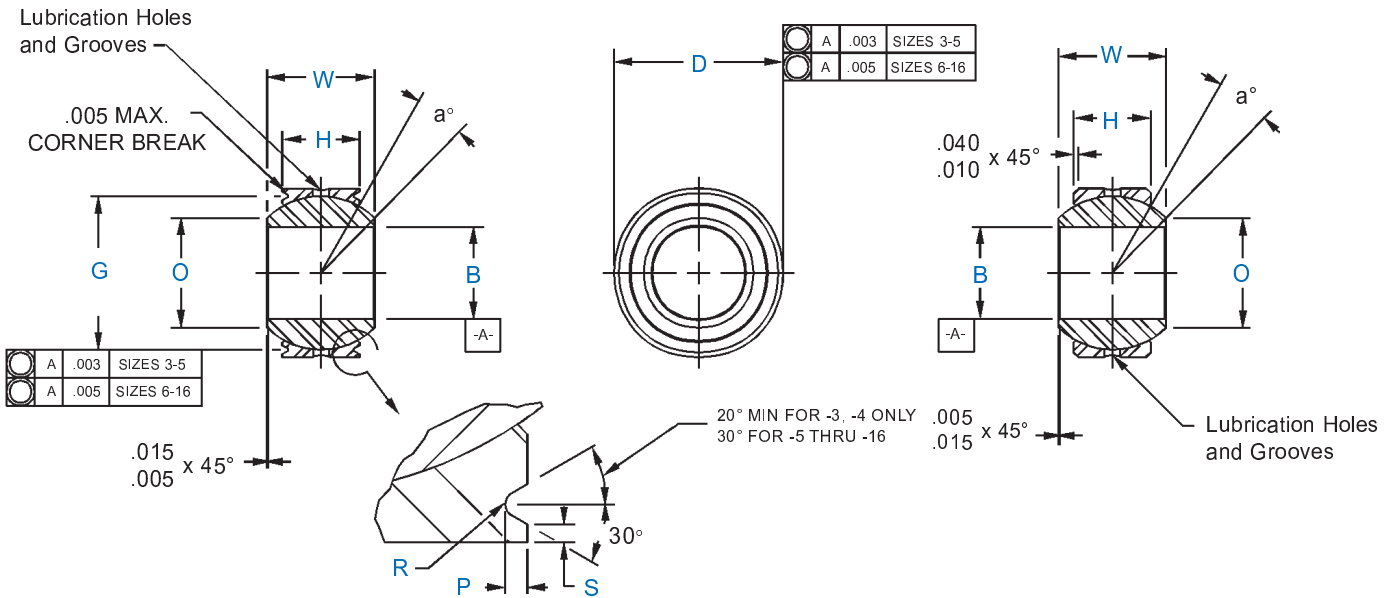

SECTION TWO

Rod End No.		DIMENSIONS IN INCHES										a°	Static Limit Load		Approx. Brg. Wt. Lbs.
Grooved	Plain	B	D	W	H	O	P*	S	G	R	Ball Dia. Ref.		Radial Lbs.	Axial Lbs.	
WC-3G	WC-3	.1900	.6250	.437	.327	.300	.025	.010	.563	.010	.531	15	2,500	1,770	.031
WC-4G	WC-4	.2500	.6250	.437	.327	.300	.025	.010	.563	.010	.531	15	5,500	1,770	.031
WC-5G	WC-5	.3125	.6875	.437	.317	.360	.025	.010	.625	.010	.593	14	9,400	1,640	.035
WC-6G	WC-6	.3750	.8125	.500	.406	.466	.035	.020	.712	.015	.687	8	13,700	2,630	.060
WC-7G	WC-7	.4375	.9375	.562	.442	.537	.035	.020	.837	.015	.781	10	20,700	3,650	.080
WC-8G	WC-8	.5000	1.0000	.625	.505	.607	.035	.020	.900	.015	.875	9	21,400	4,970	.100
WC-9G	WC-9	.5625	1.1250	.687	.536	.721	.035	.020	1.025	.015	1.000	10	26,600	5,370	.135
WC-10G	WC-10	.6250	1.1875	.750	.567	.747	.035	.020	1.087	.015	1.062	12	29,000	6,130	.160
WC-12G	WC-12	.7500	1.3750	.875	.630	.845	.055	.020	1.251	.015	1.250	13	37,000	7,730	.240
WC-14G	WC-14	.8750	1.6250	.875	.755	.995	.055	.020	1.501	.015	1.375	6	65,200	10,800	.350
WC-16G	WC-16	1.0000	2.1250	1.375	1.005	1.269	.055	.020	2.001	.015	1.875	12	104,000	19,300	.970

Specifications	
BALL	440C Stainless Steel (AMS 5630) Heat Treated Hard Chrome Plated (AMS-QQ-C-320, Class 2)
RACE	17-4 PH Stainless Steel (AMS 5643) Heat Treated

The metal to metal Spherical Bearing listed in above tables have the same envelope dimensions, materials (less PTFE), basic tolerances (except fit-up), as those that are approved to SAE-AS14102 and SAE-AS14103. Consult factory for material substitutions or dimensional modification possibilities. Radial Clearance is .002 max. (for .0005 max., use suffix-R ex: WC-6R). For dry-film lubrication on the I.D. of races, use suffix D (ex: WC-6D). For dry-film on ball bore and/or ball O.D. contact factory. *For further staking groove and assembly information, see pages 31-33. Consult factory for additional information.



HXAM-TM-500 & HXAB-TM-500 Series High Misalignment Male Rod Ends

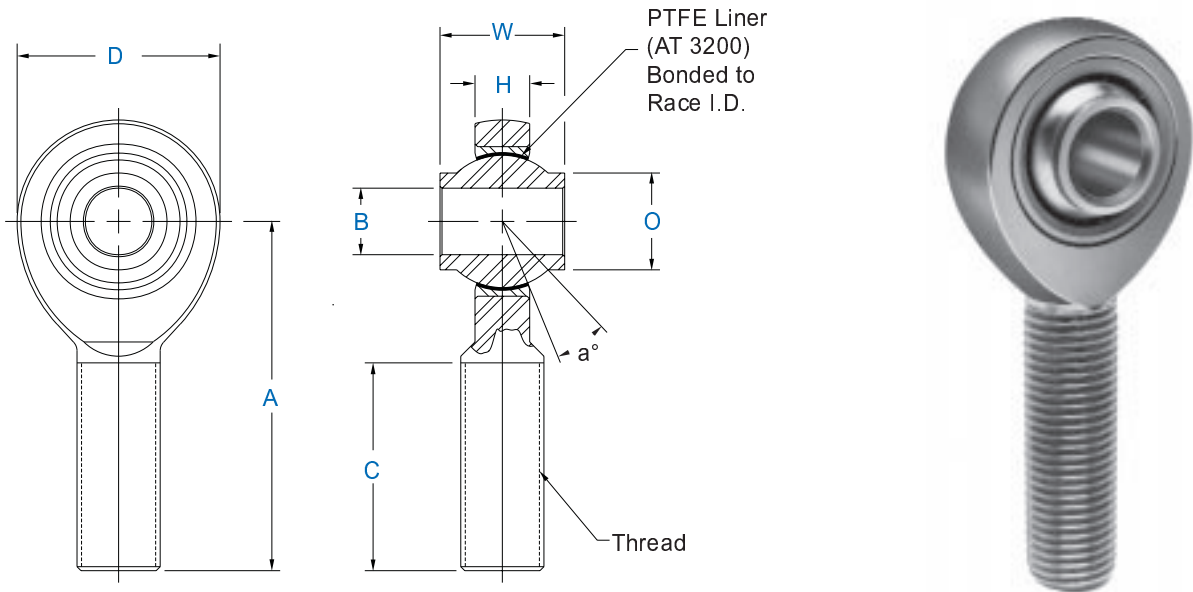

SECTION TWO

Rod End No.		DIMENSIONS IN INCHES									a° Misalign. Angle	Ultimate Radial Static Load Capacity Lbs.	Approx. Brg. Wt. Lbs.
Right Hand	Left Hand	B +.0000 - .0005	W + .000 - .005	H +.005 - .005	A + .010 - .010	D + .010 - .010	Ball Dia. Ref.	C + .062 - .031	Thread UNJF-3A	O Shoulder Dia.			
HXAM-4TM-500	HXAB-4TM-500	.2500	.593	.265	1.938	1.025	.593	1.250	3/8-24	.390	23	10,789	.12
HXAM-5TM-500	HXAB-5TM-500	.3125	.813	.355	2.125	1.150	.781	1.375	7/16-20	.512	22	11,781	.16
HXAM-6TM-500	HXAB-6TM-500	.3750	.813	.355	2.125	1.150	.781	1.375	7/16-20	.512	22	11,781	.15
HXAM-7TM-500	HXAB-7TM-500	.4375	.875	.355	2.438	1.337	.875	1.500	1/2-20	.618	21	17,105	.24
HXAM-8TM-500	HXAB-8TM-500	.5000	.937	.411	2.625	1.525	1.000	1.625	5/8-18	.730	19	23,720	.39
HXAM-10TM-500	HXAB-10TM-500	.6250	1.200	.577	2.875	1.775	1.250	1.750	3/4-16	.856	19	32,067	.60
HXAM-12TM-500	HXAB-12TM-500	.7500	1.280	.630	3.375	2.025	1.375	2.000	7/8-14	.970	18	38,660	.89

Specifications	
BODY	4340 Alloy Steel (AMS-S-5000) Heat Treated Cadmium Plated
BALL	52100 Alloy Steel (AMS 7440) Heat Treated Hard Chrome Plated (AMS-QQ-C-320, Class 2)
RACE	Alloy Steel - Heat Treated Plated for Corrosion Resistance
LINER	AT 3200 Bearing Liner, Permanently Bonded to Race I.D. Qualified to SAE-AS81820

Rod End Bearings listed in above tables are shown with SAE-AS81820 PTFE liners. These Rod Ends are available less the PTFE liners. Omit "T" from the suffix in the part number. (Ex: HXAM-6M-500)

For non-PTFE lined units the radial clearance is .002 max. (for .0005 max use suffix R)(Ex: HXAM-6RM-500).

For keyway designation, consult our engineering department.

For dry-film lubrication on I.D. of races, use suffix D (Ex: HXAM-6DM-500). For dry-film on ball bore and or ball O.D., consult factory.

Consult factory for material substitutions or dimensional modification possibilities.

Rod Ends are traceable and magnetic particle inspected. For non-traceable and non-magnetic particle inspected, contact factory.



HAB -T- 500 Series High Misalignment Spherical Bearings

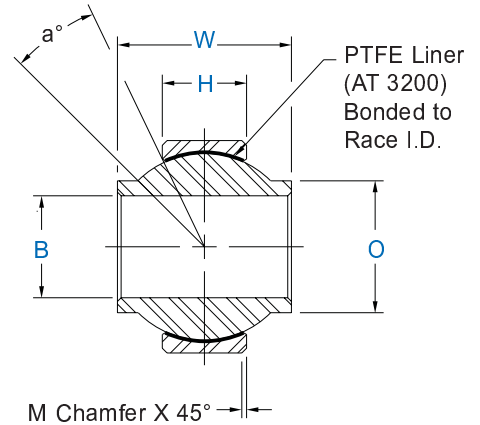
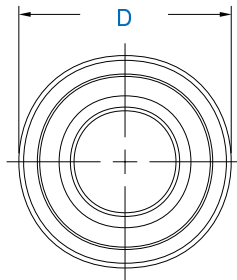

SECTION TWO

Bearing No.	DIMENSIONS IN INCHES							a° Misalign. Angle	Ultimate Radial Static Load Lbs.	Approx. Brg. Wt. Lbs.
	B +.0000 -.0005	D +.000 -.005	W +.005 -.005	H ± .005	M Ref.	O Ref.	Ball Dia. Ref.			
HAB-4T-500	.2500	.7400	.593	.255	.020	.390	.593	24	7,560	.036
HAB-5T-500	.3125	.9060	.813	.345	.030	.512	.781	23	16,975	.068
HAB-6T-500	.3750	.9060	.813	.345	.030	.512	.781	23	16,975	.068
HAB-7T-500	.4375	1.0000	.875	.345	.030	.618	.875	22	19,018	.095
HAB-8T-500	.5000	1.1250	.937	.401	.030	.730	1.000	20	25,263	.160
HAB-10T-500	.6250	1.3750	1.200	.567	.030	.856	1.250	20	44,651	.245
HAB-12T-500	.7500	1.5625	1.280	.620	.035	.970	1.375	18	53,707	.315

Specifications	
BALL	52100 Alloy Steel (AMS 7440) Heat Treated Hard Chrome Plated (AMS-QQ-C-320 Class 2)
LINER	AT3200 Bearing Liner, Permanently Bonded to Race I.D. Qualified to SAE-AS81820
RACE	Alloy Steel Heat Treated

Spherical Bearings listed in above tables are shown with SAE-AS81820 PTFE liners. These bearings are available less the PTFE liners. Omit "T" from the suffix in the part number (Ex: HAB-6-500).

For non-PTFE lined units the radial clearance is .002 max. (for .0005 max use suffix R)(Ex: HXAM-6RM-500).

"V" groove-type bearings are available. Consult factory for dimensions and staking groove data.

For dry-film lubrication on I.D. of races, use suffix D (Ex: HAB-6D-500). For dry-film on ball bore and or ball O.D., consult factory.

Consult factory for material substitutions, dimensional modification possibilities, lubrication holes and grooves in balls.

Bearings are traceable. For non-traceable units, contact factory.



GMM-M & GMB-M Series Male Rod Ends
General Aviation - Precision

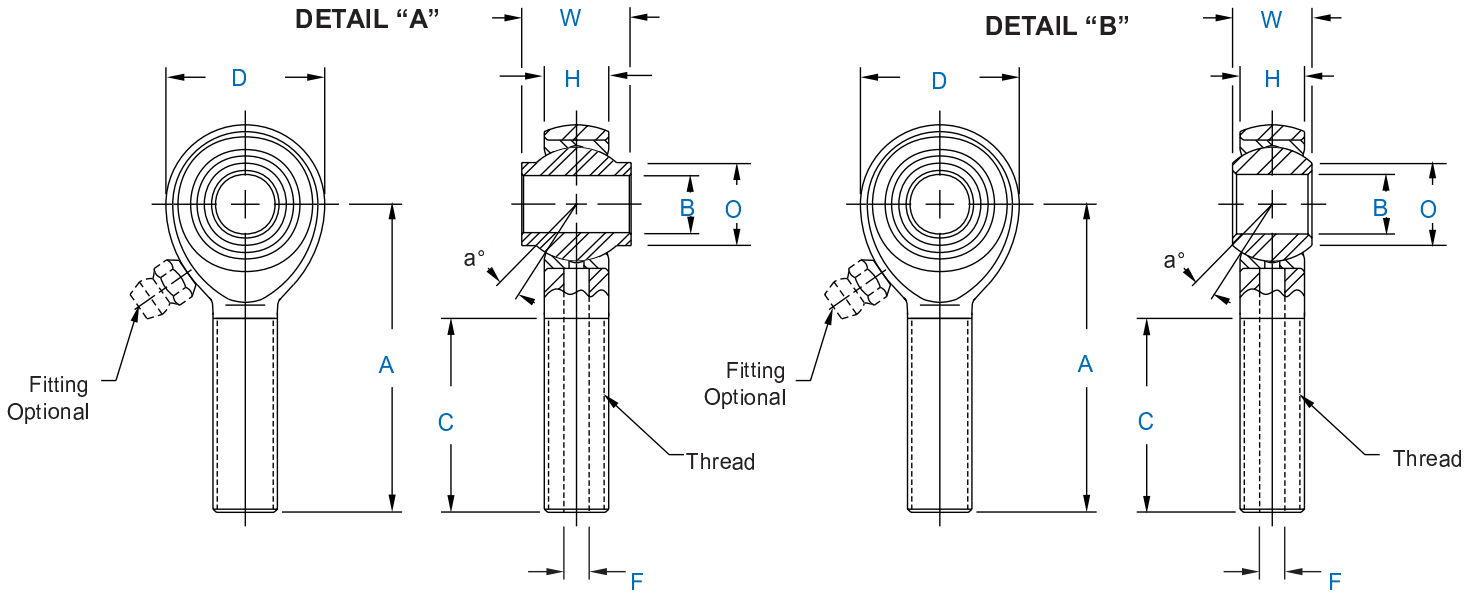

DETAIL "A"



DETAIL "B"

Specifications	
BODY	Low Carbon Steel, Protective Coated for Corrosion Resistance.
BALL	Alloy steel, Heat treated, Hard Chrome Plated (AMS-QQ-C-320, Class 2).
RACE	Low Carbon Steel, Protective Coated for Corrosion Resistance.

Note: Units are traceable and magnetic particle inspected after assembly.

SECTION THREE

Rod End No.		DIMENSIONS IN INCHES											a°	Ultimate	Approx.
Right Hand	Left Hand	Ball Shoulder Configuration	B +.0015 -.0005	W +.000 -.005	H ±.005	A ±.015	D ±.010	Shoulder Dia. Ref.	Ball Dia. Ref.	Min. C	Drilled Hole Dia. Ref.	Thread UNF-3A	Misalign. Angle	Radial Static Load Capacity	Brg. Wt. Lbs.
GMM-3M-470	GMB-3M-470	See Detail "A"	.1900	.437	.281	1.562	.750	.315	.500	.969	-	1/4-28	17	2,158	.05
GMM-3M-570	GMB-3M-570	See Detail "A"	.1900	.437	.328	1.375	.875	.315	.500	.750	.113	5/16-24	10	2,823	.07
GMM-3M-670	GMB-3M-670	See Detail "A"	.1900	.437	.328	1.375	.750	.315	.500	.750	.113	3/8-24	10	2,850	.08
GMM-3M-680	GMB-3M-680	See Detail "B"	.1900	.500	.375	1.812	.833	.319	.593	1.062	.136	3/8-24	18	3,269	.09
GMM-4M-470	GMB-4M-470	See Detail "B"	.2500	.437	.304	1.562	.812	.353	.562	.969	-	1/4-28	18	2,158	.07
GMM-4M-675	GMB-4M-675	See Detail "B"	.2500	.484	.335	2.312	.875	.395	.625	1.500	.136	3/8-24	18	3,160	.11
GMM-4M-680	GMB-4M-680	See Detail "B"	.2500	.500	.335	2.062	.875	.375	.625	1.500	.159	3/8-24	21	2,985	.10

Load ratings apply only to rod ends without grease fittings. For load ratings with fittings, please contact our engineering department. For Rod End bearings which are non-traceable or non-magnetic particle inspected, consult factory.

Units are supplied without grease fittings. When grease fittings are required, specify by adding suffixes as designated.

Z Zerk type fitting Ex: GMM-3MZ-470
F Flush type fitting Ex: GMM-3MF-470



GMW-M & GMG-M Series Female Rod Ends
General Aviation - Precision

DETAIL "A"

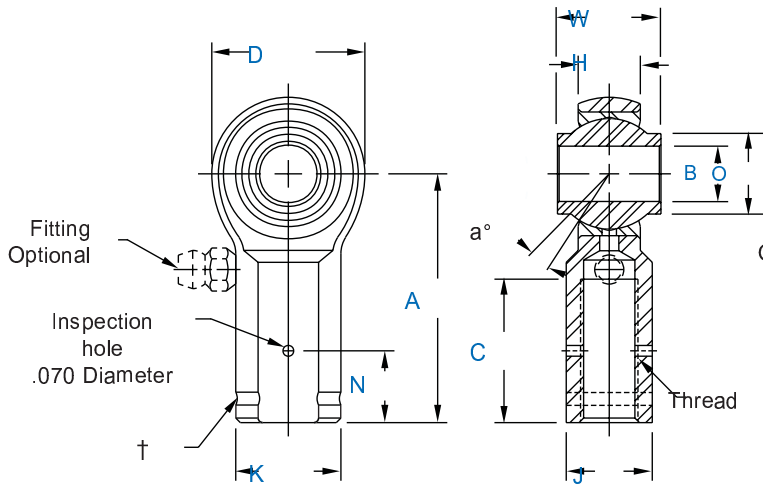

DETAIL "B"

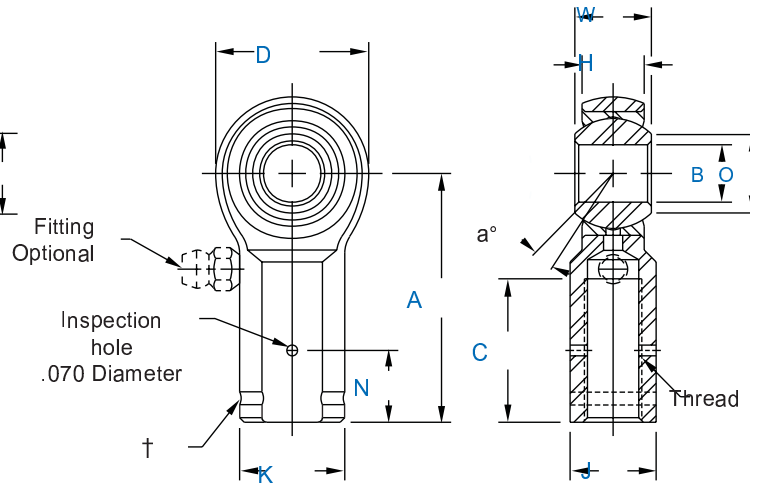

DETAIL "A"

Specifications	
BODY	Low Carbon Steel, Protective Coated for Corrosion Resistance.
BALL	Alloy steel, Heat treated, Hard Chrome Plated (AMS-QQ-C-320, Class 2).
RACE	Low Carbon Steel, Protective Coated for Corrosion Resistance.



DETAIL "B"

Note: Units are traceable and magnetic particle inspected after assembly.

Rod End No.		DIMENSIONS IN INCHES													a° Misalign. Angle	Ultimate Radial Static Load Capacity	Approx. Brg. Wt. Lbs.
Right Hand	Left Hand	Ball Shoulder Configuration	B +.0015 -.0005	W +.000 -.005	H ±.005	A ±.015	D ±.010	K ±.010	J ±.010	N ±.005	O Shoulder Dia. Ref.	Ball Dia. Ref.	C +.062 -.031	Thread UNF-3B			
GMW-3M-470	GMG-3M-470	See Detail "A"	.1900	.437	.328	1.375	.750	.468	.375	.312	.315	.500	.750	1/4-28	10	2,881	.06
GMW-3M-471	GMG-3M-471	See Detail "A"	.1900	.437	.328	1.062	.750	.375	-	-	.315	.500	.437	1/4-28	10	2,881	.05
GMW-3M-480	GMG-3M-480	See Detail "A"	.1900	.500	.375	1.375	.812	.468	.375	.312	.312	.562	.750	1/4-28	15	3,152	.08
GMW-3M-570	GMG-3M-570	See Detail "A"	.1900	.437	.328	1.375	.750	.500	.437	.312	.315	.500	.750	5/16-24	10	2,881	.07
GMW-4M-470	GMG-4M-470	See Detail "B"	.2500	.437	.304	1.375	.812	.468	.437	.312	.353	.562	.750	1/4-28	18	2,950	.08
GMW-4M-595	GMG-4M-595	See Detail "A"	.2500	.593	.406	1.469	.938	.500	-	.312	.485	.687	.844	5/16-24	10	3,359	.10

† Left hand units identification groove near end of shank.
Rod End bearings which are non-traceable or non-magnetic particle inspected consult factory.

Units are supplied without grease fittings. When grease fittings are required, specify by adding suffixes as designated.

Z Zerk type fitting Ex: GMW-3MZ-470
F Flush type fitting Ex: GMW-3MF-470

Load ratings apply only to rod ends without grease fittings. For load ratings with fittings, please consult our engineering department.



MM-M-500 & MB-M-500 Series Male Rod Ends

General Aviation - Precision

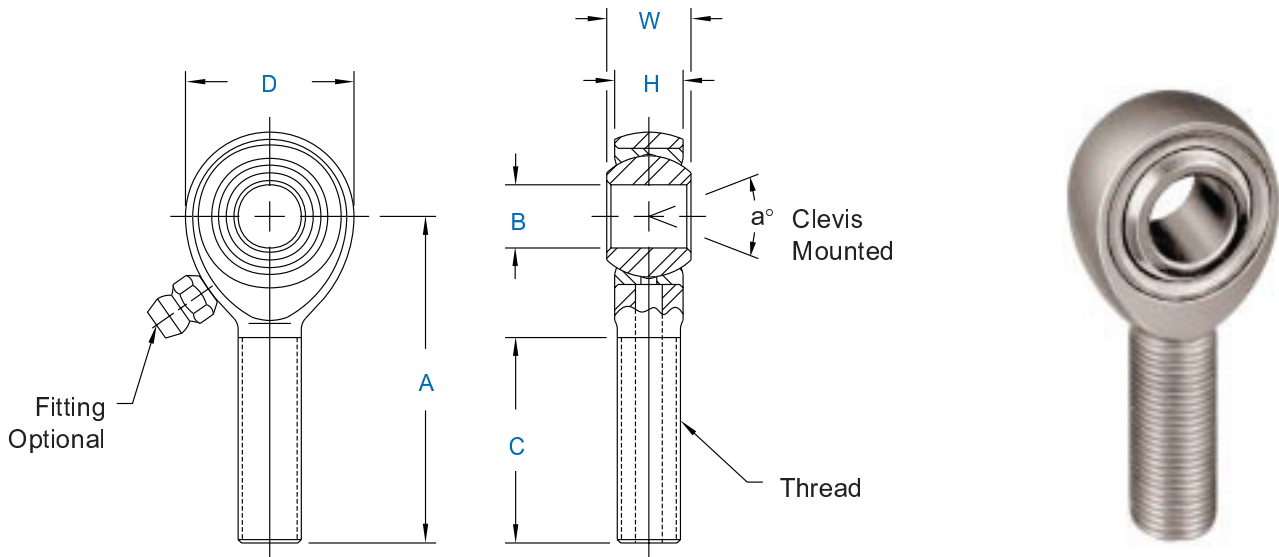

Specifications	
BODY	Low Carbon Steel, Protective Coated for Corrosion Resistance.
BALL	Alloy steel, Heat treated, Hard Chrome Plated (AMS-QQ-C-320, Class 2).
RACE	Low Carbon Steel, Protective Coated for Corrosion Resistance.

Note: Units are traceable and magnetic particle inspected after assembly.

Aurora No.		DIMENSIONS IN INCHES								a°	Ultimate	Approx.
Right Hand	Left Hand	B +.0015 -.0005	W +.000 .005	H ±.005	A ±.015	D ±.010	Ball Dia. Ref.	C +.062 -.031	Thread UNF-3A	Misalign. Angle Min.	Static Radial Load Lbs.	Brg. Wt. Lbs.
MM-2M-500	MB-2M-500	.1250	.250	.187	.937	.500	.312	.562	6-32 ¹	16	502	.013
MM-3M-500	MB-3M-500	.1900	.312	.250	1.250	.625	.437	.750	10-32	13	1,169	.028
MM-4M-500	MB-4M-500	.2500	.375	.281	1.562	.750	.500	1.000	1/4-28	16	2,158	.043
MM-5M-500	MB-5M-500	.3125	.437	.344	1.875	.875	.625	1.250	5/16-24	14	2,784	.072
MM-6M-500	MB-6M-500	.3750	.500	.406	1.938	1.000	.719	1.250	3/8-24	12	3,915	.112
MM-7M-500	MB-7M-500	.4375	.562	.437	2.125	1.125	.812	1.375	7/16-20	14	4,218	.160
MM-8M-500	MB-8M-500	.5000	.625	.500	2.438	1.312	.937	1.500	1/2-20	12	6,660	.249
MM-10M-500	MB-10M-500	.6250	.750	.562	2.625	1.500	1.125	1.625	5/8-18	16	7,364	.382
MM-12M-500	MB-12M-500	.7500	.875	.687	2.875	1.750	1.312	1.750	3/4-16	14	11,518	.602
MM-14M-500	MB-14M-500	.8750	.875	.765	3.375	2.000	1.375	2.000	7/8-14	7	18,476	.906
MM-14M-1-500	MB-14M-1-500	.8750	.875	.687	3.375	2.000	1.312	1.875	7/8-14	12	22,843	.906
MM-16M-500	MB-16M-500	1.0000	1.375	1.000	4.125	2.750	1.875	2.125	1 1/4-12	17	43,541	2.406
MM-16M-1-500	MB-16M-1-500	1.0000	1.375	1.000	4.125	2.750	1.875	2.125	1-14 ²	17	43,541	2.127
MM-16M-2-500	MB-16M-2-500	1.0000	1.375	1.000	4.125	2.750	1.875	2.125	1-12	17	43,541	2.127

* Grease fitting not available.

1 Threads 6-32 UNC.

2 Threads 1-14 UNS.

3 Tolerance variation: "D" ± .020, "A" ± .020, "B" + .0035, -.0005, "H" ± .010

3 Body material: 4130 steel not heat treated.

Solid shank add suffix "Y" (Ex: MM-6YM-500).

THESE ROD ENDS NOT NORMALLY STOCKED - CHECK FOR AVAILABILITY.

Units are supplied without grease fittings. When grease fittings are required, specify by adding suffixes as designated.

Z Zerk type fitting Ex: MM-6Z

F Flush type fitting Ex: MM-6F

Load ratings apply only to rod ends without grease fittings. For load ratings with fittings, please consult our engineering department. For Rod End bearings which are non-traceable or non-magnetic particle inspected consult factory.



MW-M-500 & MG-M-500 Series Female Rod Ends

General Aviation - Precision

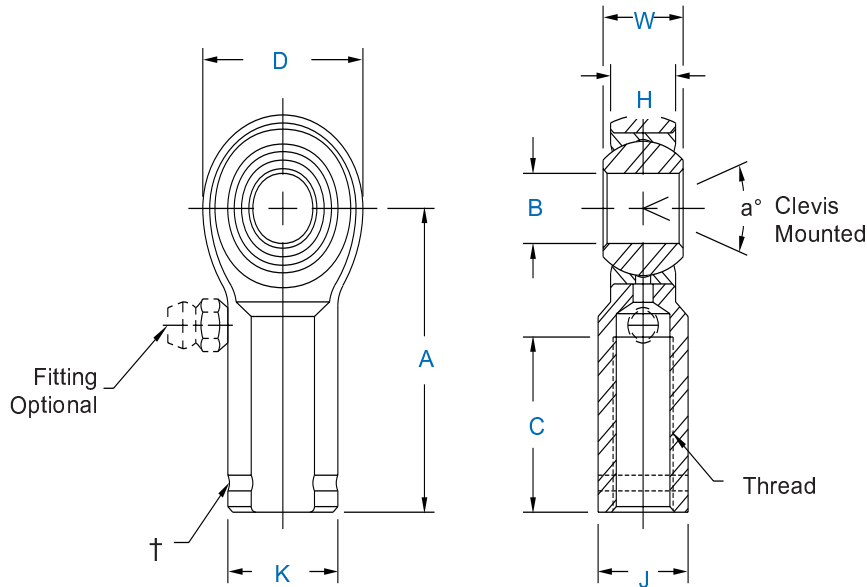

Specifications	
BODY	Low Carbon Steel, Protective Coated for Corrosion Resistance.
BALL	Alloy steel, Heat treated, Hard Chrome Plated (AMS-QQ-C-320, Class 2).
RACE	Low Carbon Steel, Protective Coated for Corrosion Resistance.

Note: Units are traceable and magnetic particle inspected after assembly.

AURORA NO.		DIMENSIONS IN INCHES										a° Misalign. Angle	Ult. Static Radial Load Lbs.	Approx. Brg. Wt. Lbs.
Right Hand	Left Hand	B +.0015 -.0005	W +.000 +.005	H ±.005	A ±.015	D ±.010	K ±.010	J ±.010	Ball Dia. Ref.	C +.062 -.031	Thread UNF-2B			
[*] MW-2M-500	MG-2M-500	.1250	.250	.187	.812	.500	.312	.250	.312	.437	6-32 ¹	16	1,202	.019
MW-3M-500	MG-3M-500	.1900	.312	.250	1.062	.625	.406	.312	.437	.562	10-32	13	1,531	.038
MW-4M-500	MG-4M-500	.2500	.375	.281	1.312	.750	.469	.375	.500	.750	1/4-28	16	2,539	.059
MW-5M-500	MG-5M-500	.3125	.437	.344	1.375	.875	.500	.437	.625	.750	5/16-24	14	3,133	.092
MW-6M-500	MG-6M-500	.3750	.500	.406	1.625	1.000	.687	.562	.719	.937	3/8-24	12	3,915	.152
MW-7M-500	MG-7M-500	.4375	.562	.437	1.812	1.125	.750	.625	.812	1.062	7/16-20	14	4,218	.198
MW-8M-500	MG-8M-500	.5000	.625	.500	2.125	1.312	.875	.750	.937	1.187	1/2-20	12	6,660	.329
MW-10M-500	MG-10M-500	.6250	.750	.562	2.500	1.500	1.000	.875	1.125	1.500	5/8-18	16	7,364	.477
MW-12M-500	MG-12M-500	.7500	.875	.687	2.875	1.750	1.125	1.000	1.312	1.750	3/4-16	14	11,518	.723
MW-14M-500	MG-14M-500	.8750	.875	.765	3.375	2.000	1.300	1.125	1.375	1.875	7/8-14	7	18,476	1.030
MW-14M-1-500	MG-14M-1-500	.8750	.875	.687	3.500	2.000	1.312	1.187	1.312	1.812	7/8-14	12	22,843	1.030
³ MW-16M-500	MG-16M-500	1.0000	1.375	1.000	4.125	2.750	1.625	1.500	1.875	2.125	1 1/4-12	17	40,889	2.125
³ MW-16M-1-500	MG-16M-1-500	1.0000	1.375	1.000	4.125	2.750	1.625	1.500	1.875	2.125	1-14 ²	17	43,541	2.410
³ MW-16M-2-500	MG-16M-2-500	1.0000	1.375	1.000	4.125	2.750	1.625	1.500	1.875	2.125	1-12	17	43,541	2.410

† Left hand units have identification groove near end of shank.

* Grease fitting not available.

¹Threads 6-32 UNC.

²Threads 1-14 UNS.

³Tolerance variation: "D" ± .020, "A" ± .020 "B" + .0035, - .0005,

"H" ± .010, "K" ± .015, "J" ± .015

³ Body Material: 4130 steel not heat treated.

THESE ROD ENDS NOT NORMALLY STOCKED - CHECK FOR AVAILABILITY.

Units are supplied without grease fittings. When grease fittings are required, specify by adding suffixes as designated.

Z Zerk type fitting Ex: MW-3ZM-500

F Flush type fitting Ex: MW-3FM-500

For Rod End bearings which are non-traceable or non-magnetic particle inspected, consult factory.



MM-TM-500 & MB-TM-500 Series
Male Rod Ends (PTFE) Lined
 General Aviation - Precision

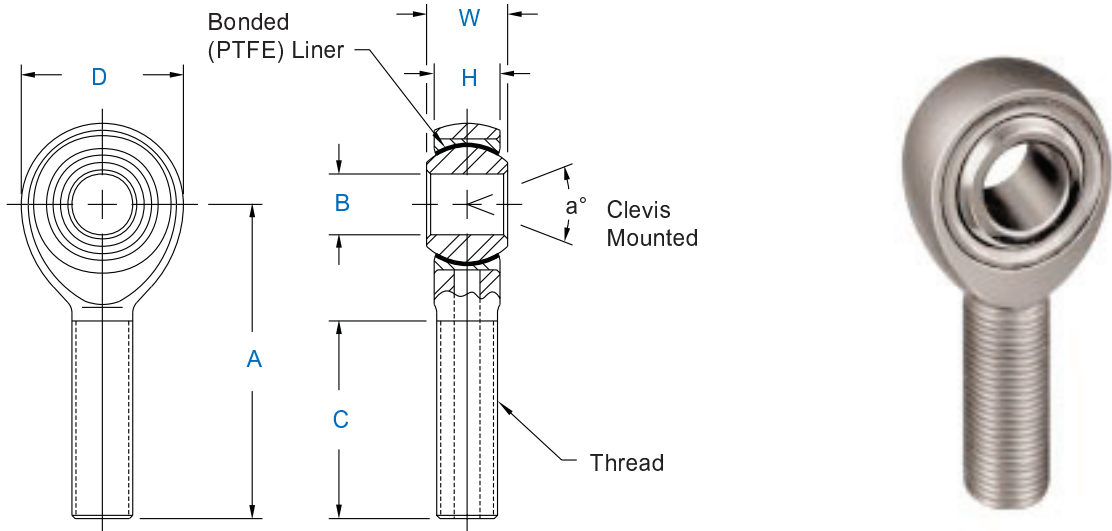

Specifications	
BODY	Low Carbon Steel, Protective Coated for Corrosion Resistance
BALL	Alloy Steel, Heat Treated, Hard Chrome Plated (AMS-QQ-C-320, Class 2)
RACE	Low Carbon Steel, Protective Coated for Corrosion Resistance
LINER	PTFE Bearing Liner, Permanently Bonded to Race I.D.

Note: Units are traceable and magnetic particle inspected after assembly.

Aurora No.		DIMENSIONS IN INCHES								a°	Ultimate	Approx.
Right Hand	Left Hand	B + .0015 - .0005	W + .000 - .005	H ± .005	A ± .015	D ± .010	Ball Dia. Ref.	C + .062 - .031	Thread UNF-3A	Misalign. Angle Min.	Static Radial Load Lbs.	Brg. Wt. Lbs.
MM-3TM-500	MB-3TM-500	.1900	.312	.250	1.250	.625	.437	.750	10-32	13	1,169	.028
MM-4TM-500	MB-4TM-500	.2500	.375	.281	1.562	.750	.500	1.000	1/4-28	16	2,158	.043
MM-5TM-500	MB-5TM-500	.3125	.437	.344	1.875	.875	.625	1.250	5/16-24	14	2,784	.072
MM-6TM-500	MB-6TM-500	.3750	.500	.406	1.938	1.000	.719	1.250	3/8-24	12	3,915	.112
MM-7TM-500	MB-7TM-500	.4375	.562	.437	2.125	1.125	.812	1.375	7/16-20	14	4,218	.160
MM-8TM-500	MB-8TM-500	.5000	.625	.500	2.438	1.312	.937	1.500	1/2-20	12	6,660	.249
MM-10TM-500	MB-10TM-500	.6250	.750	.562	2.625	1.500	1.125	1.625	5/8-18	16	7,364	.382
MM-12TM-500	MB-12TM-500	.7500	.875	.687	2.875	1.750	1.312	1.750	3/4-16	14	11,518	.602
1 MM-16TM-500	MB-16TM-500	1.0000	1.375	1.000	4.125	2.750	1.875	2.125	1 1/4-12	17	43,541	2.406

1 Tolerance variation: "D" ± .020, "A" ± .020, "B" + .0035, - .0005, "H" ± .010
 1 Body Material: 4130 steel not heat treated.

Solid shank add suffix "Y" (Ex: MM - 6TYM-500)
 For Rod End bearings which are non-traceable or non-magnetic particle inspected, consult factory.



MW-TM-500 & MG-TM-500 Series
Female Rod Ends (PTFE) Lined
 General Aviation - Precision

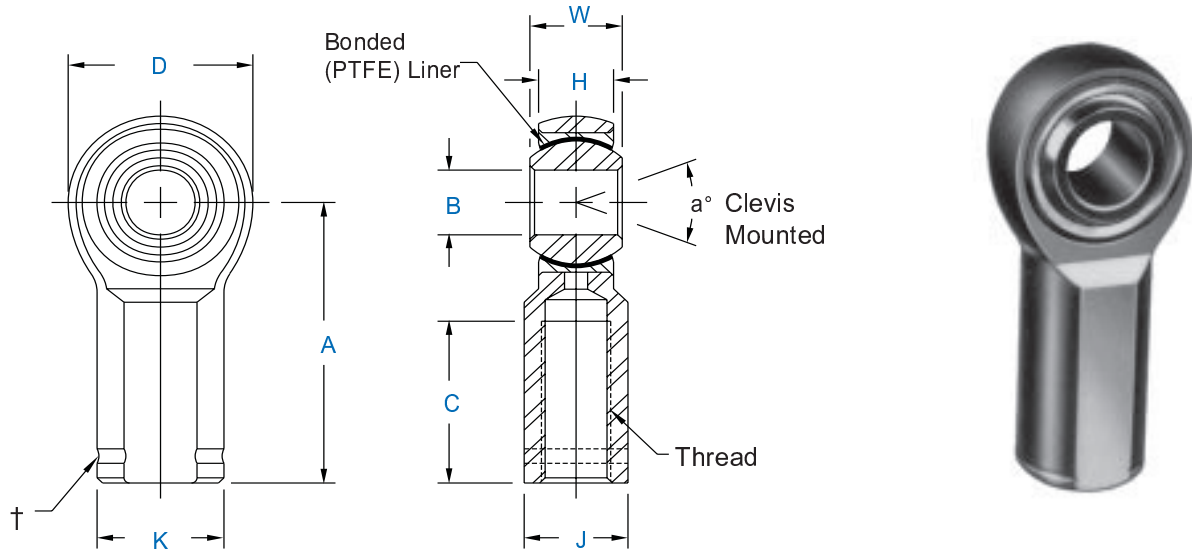

Specifications	
BODY	Low Carbon Steel, Protective Coated for Corrosion Resistance
BALL	Alloy Steel, Heat Treated, Hard Chrome Plated (AMS-QQ-C-320, Class 2)
RACE	Low Carbon Steel, Protective Coated for Corrosion Resistance
LINER	PTFE Bearing Liner, Permanently Bonded to Race I.D.

Note: Units are traceable and magnetic particle inspected after assembly.

AURORA NO.		DIMENSIONS IN INCHES										a° Misalign. Angle	Ult. Static Radial Load Lbs.	Approx. Brg. Wt. Lbs.
Right Hand	Left Hand	B +.0015 -.0005	W +.000 +.005	H ± .005	A ± .015	D ± .010	K ± .010	J ± .010	Ball Dia. Ref.	C +.062 -.031	Thread UNF-2B			
MW-3TM-500	MG-3TM-500	.1900	.312	.250	1.062	.625	.406	.312	.437	.562	10-32	13	1,531	.038
MW-4TM-500	MG-4TM-500	.2500	.375	.281	1.312	.750	.469	.375	.500	.750	1/4-28	16	2,539	.059
MW-5TM-500	MG-5TM-500	.3125	.437	.344	1.375	.875	.500	.437	.625	.750	5/16-24	14	3,133	.092
MW-6TM-500	MG-6TM-500	.3750	.500	.406	1.625	1.000	.687	.562	.719	.937	3/8-24	12	3,915	.152
MW-7TM-500	MG-7TM-500	.4375	.562	.437	1.812	1.125	.750	.625	.812	1.062	7/16-20	14	4,218	.198
MW-8TM-500	MG-8TM-500	.5000	.625	.500	2.125	1.312	.875	.750	.937	1.187	1/2-20	12	6,660	.329
MW-10TM-500	MG-10TM-500	.6250	.750	.562	2.500	1.500	1.000	.875	1.125	1.500	5/8-18	16	7,364	.477
MW-12TM-500	MG-12TM-500	.7500	.875	.687	2.875	1.750	1.125	1.000	1.312	1.750	3/4-16	14	11,518	.723
MW-16TM-500	MG-16TM-500	1.0000	1.375	1.000	4.125	2.750	1.625	1.500	1.875	2.125	1 1/4-12	17	40,889	2.125

1 Tolerance variation: "D" ± .020, "A" ± .020 "B" + .0035, - .0005, "H" ± .010, "K" ± .015, "J" ± .015

1 Body Material: 4130 steel not heat treated.

† Left hand units have identification groove near end of shank. For Rod End bearings which are non-traceable or non-magnetic particle inspected, consult factory.

SECTION THREE



MM-M-M-500 & MB-M-M-500 Series
Male Rod Ends - Metric
 General Aviation - Precision

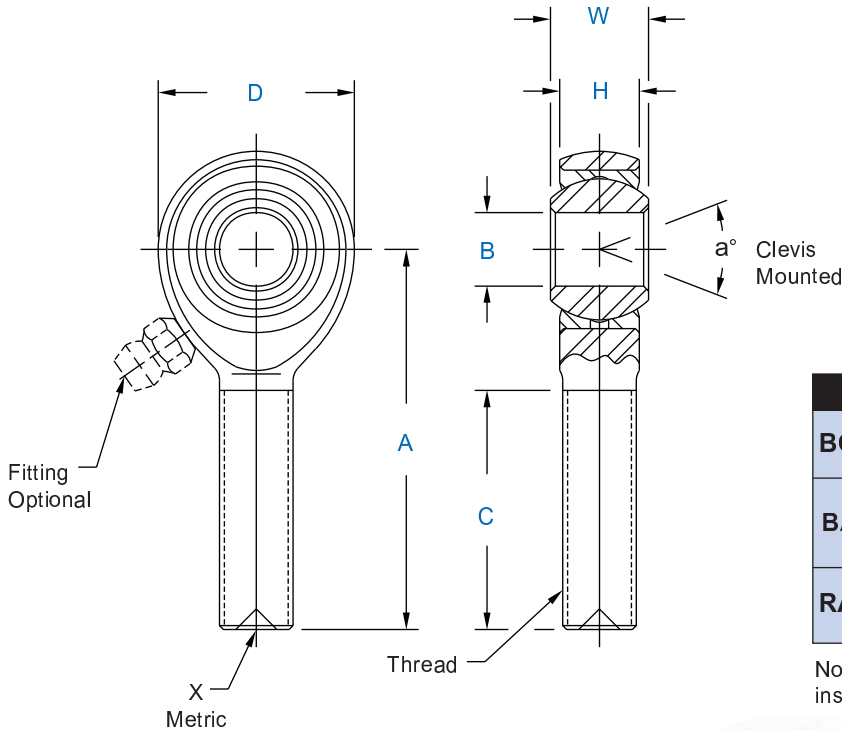

Specifications	
BODY	Low Carbon Steel, Protective Coated for Corrosion Resistance.
BALL	Alloy steel, Heat treated, Hard Chrome Plated (AMS-QQ-C-320, Class 2).
RACE	Low Carbon Steel, Protective Coated for Corrosion Resistance.

Note: Units are traceable and magnetic particle inspected after assembly.

SECTION THREE

AURORA NO.		DIMENSIONS IN MILLIMETERS								a°	Ult. Static Radial Load	Approx. Brg. Wt.
Right Hand	Left Hand	B + .065 - .013	W ± .13	H ± .13	A ± .40	D ± .38	Ball Dia. Ref.	C ± 1.00	Thread	Misalign. Angle	Newton	Grams
MM-M3M-500	MB-M3M-500	3	6	4.75	27	12.50	7.93	15	M3 X 0.5	13	1,775	7
MM-M5M-500	MB-M5M-500	5	8	6.25	33	16.00	11.10	20	M5 X 0.8	14	5,168	13
MM-M6M-500	MB-M6M-500	6	9	7.00	36	19.00	12.70	22	M6 X 1.0	13	7,296	18
MMF-M8M-500	MBF-M8M-500	8	12	8.75	42	22.25	15.88	25	M8 X 1.0	18	13,591	31
MM-M8M-500	MB-M8M-500								M8 X 1.25			
MMF-M10M-500	MBF-M10M-500	10	14	10.50	48	27.00	19.05	29	M10 X 1.25	17	20,603	68
MM-M10M-500	MB-M10M-500								M10 X 1.5			
MMF-M12M-500	MBF-M12M-500	12	16	12.00	54	30.00	22.23	33	M12 X 1.25	17	18,215	78
MM-M12M-500	MB-M12M-500								M12 X 1.75			
MMF-M14M-500	MBF-M14M-500	14	19	13.50	60	34.75	25.40	36	M14 X 1.5	21	29,840	118
MM-M14M-500	MB-M14M-500								M14 X 2.0			
MMF-M16M-500	MBF-M16M-500	16	21	14.25	66	38.00	28.58	40	M16 X 1.5	23	32,223	173
MM-M16M-500	MB-M16M-500								M16 X 2.0			
MM-M18M-500	MB-M18M-500	18	23	16.25	72	42.00	31.75	44	M18 X 1.5	21	41,303	260
MMF-M20M-500	MBF-M20M-500	20	25	18.00	78	46.00	34.93	47	M20 X 1.5	20	50,952	290
MM-M20M-500	MB-M20M-500								M20 X 2.5			
MM-M22M-500	MB-M22M-500	22	28	19.50	86	50.00	38.10	51	M22 X 1.5	22	56,238	315
MM-M25M-500	MB-M25M-500	25	31	22.00	95	60.00	42.86	57	M24 X 2.0	19	104,435	500
MM-M30M-500	MB-M30M-500	30	37	25.50	105	70.00	50.80	66	M30 X 2.0	21	147,238	1,090

X Designates metric threads.

For Rod End bearings which are non-traceable or non-magnetic particle inspected, consult factory.

THESE ROD ENDS NOT NORMALLY STOCKED - CHECK FOR AVAILABILITY.

Units are supplied without grease fittings. When grease fittings are required, specify by adding suffixes as designated.

Z Zerk type fitting Ex: MM-M10ZM-500

F Flush type fitting Ex: MM-M10FM-500

Load ratings apply only to rod ends without grease fittings. For load ratings with fittings, please consult our engineering department.



MW-M-M-500 & MG-M-M-500 Series
Female Rod Ends - Metric
 General Aviation - Precision

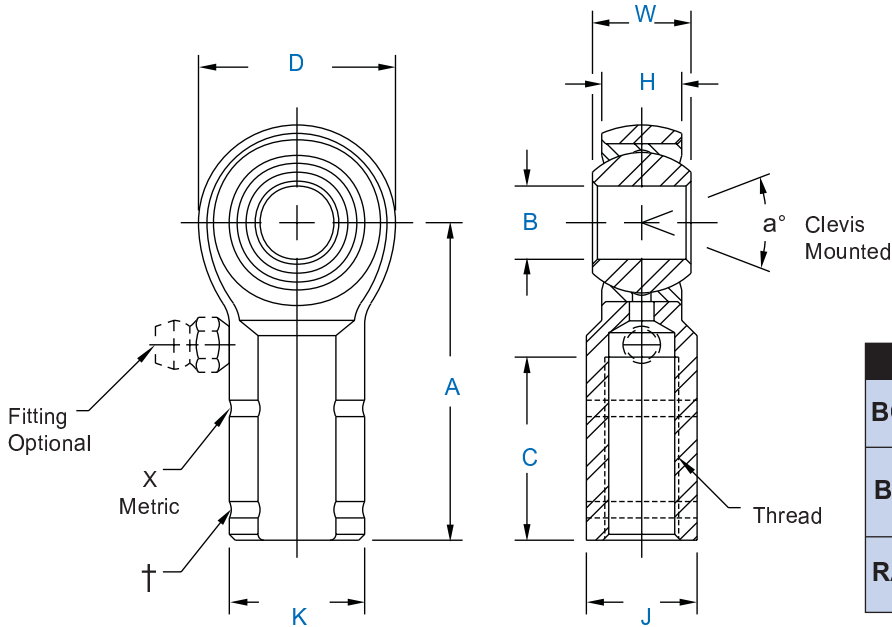

Specifications	
BODY	Low Carbon Steel, Protective Coated for Corrosion Resistance.
BALL	Alloy steel, Heat treated, Hard Chrome Plated (AMS-QQ-C-320, Class 2).
RACE	Low Carbon Steel, Protective Coated for Corrosion Resistance.

Note: Units are traceable and magnetic particle inspected after assembly.

Rod End No.		DIMENSIONS IN MILLIMETERS										a°	Ult.	Approx.
Right Hand	Left Hand	B + .065 - .013	W ± .13	H ± .13	A ± .40	D ± .38	K ± .25	J ± .25	Ball Dia. Ref.	C ± 1.00	Thread	Misalign. Angle	Static Load Newtons	Brg. Wt. Grams
MW-M3M-500	MG-M3M-500	3	6	4.75	21	12.50	8	7	7.93	10	M3 X 0.5	13	4,972	10
MW-M5M-500	MG-M5M-500	5	8	6.25	27	16.00	11	9	11.10	14	M5 X 0.8	14	7,090	17
MW-M6M-500	MG-M6M-500	6	9	7.00	30	19.00	13	11	12.70	14	M6 X 1.0	13	10,573	25
MWF-M8M-500	MGF-M8M-500	8	12	8.75	36	22.25	16	14	15.88	17	M8 X 1.0	18	14,072	40
MW-M8M-500	MG-M8M-500										M8 X 1.25			
MWF-M10M-500	MGF-M10M-500	10	14	10.50	43	27.00	19	17	19.05	21	M10 X 1.25	17	20,603	80
MW-M10M-500	MG-M10M-500										M10 X 1.5			
MWF-M12M-500	MGF-M12M-500	12	16	12.00	50	30.00	22	19	22.23	24	M12 X 1.25	17	18,215	95
MW-M12M-500	MG-M12M-500										M12 X 1.75			
MWF-M14M-500	MGF-M14M-500	14	19	13.50	57	34.75	25	22	25.40	27	M14 X 1.5	21	29,840	160
MW-M14M-500	MG-M14M-500										M14 X 2.0			
MWF-M16M-500	MGF-M16M-500	16	21	14.25	64	38.00	27	22	28.58	33	M16 X 1.5	23	32,223	215
MW-M16M-500	MG-M16M-500										M16 X 2.0			
MW-M18M-500	MG-M18M-500	18	23	16.25	71	42.00	31	27	31.75	36	M18 X 1.5	21	41,303	300
MWF-M20M-500	MGF-M20M-500	20	25	18.00	77	46.00	34	30	34.93	40	M20 X 1.5	20	50,952	350
MW-M20M-500	MG-M20M-500										M20 X 2.5			
MW-M22M-500	MG-M22M-500	22	28	19.50	86	50.00	37	32	38.10	43	M22 X 1.5	22	56,238	390
MW-M25M-500	MG-M25M-500	25	31	22.00	95	60.00	42	36	42.86	48	M24 X 2.0	19	104,435	700
MW-M30M-500	MG-M30M-500	30	37	25.50	105	70.00	50	41	50.80	56	M30 X 2.0	21	147,238	970

X Designates metric threads.

For Rod End bearings which are non-traceable or non-magnetic particle inspected, consult factory.

† Left hand units have identification groove.

THESE ROD ENDS NOT NORMALLY STOCKED - CHECK FOR AVAILABILITY.

Units are supplied without grease fittings. When grease fittings are required, specify by adding suffixes as designated.

Z Zerk type fitting
 F Flush type fitting

Ex: MW-M10ZM-500
 Ex: MW-M10FM-500



CM & CB Series Male Rod Ends

General Aviation - Economy

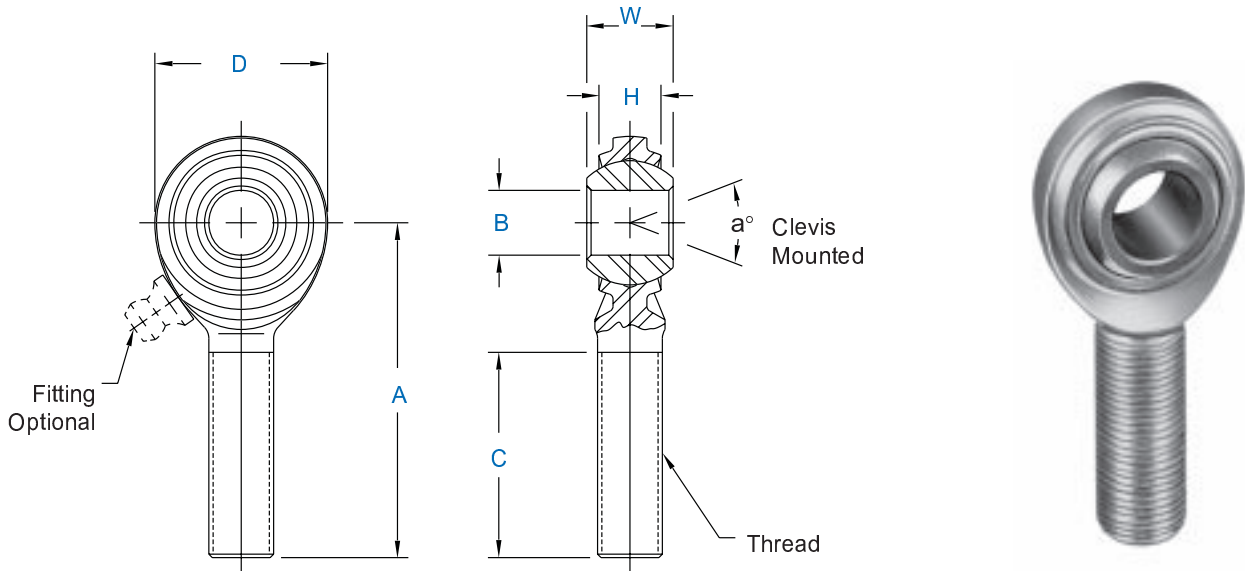

Specifications	
BODY	Low Carbon Steel, Protective Coated for Corrosion Resistance.
BALL	Sintered steel, Heat treated, Oil Impregnated.
ALTERNATE BALL	Alloy Steel, Heat Treated, Hard Chrome Plated.

Note: Units are **NOT** traceable and **NOT** magnetic particle inspected.

SECTION THREE

Rod End No.		DIMENSIONS IN INCHES								a°	Ult. Static Radial Load Lbs.	Approx. Brg. Wt. Lbs.
Right Hand	Left Hand	B +.0025 -.0005	W ± .005	H Ref.	A ± .015	D ± .010	Ball Dia. Ref.	C +.062 -.031	Thread UNF-3A	Misalign. Angle		
* CM-3	CB-3	.1900	.312	.234	1.250	.625	.437	.750	10-32	20	1,204	.03
* CM-4	CB-4	.2500	.375	.250	1.562	.750	.500	1.000	1/4-28	27	2,212	.04
* CM-5	CB-5	.3125	.437	.312	1.875	.875	.625	1.250	5/16-24	22	3,577	.07
CM-6	CB-6	.3750	.500	.359	1.938	1.000	.719	1.250	3/8-24	22	5,068	.11
CM-7	CB-7	.4375	.562	.406	2.125	1.125	.812	1.375	7/16-20	21	6,345	.15
CM-8	CB-8	.5000	.625	.453	2.438	1.312	.937	1.500	1/2-20	20	8,338	.24
CM-10	CB-10	.6250	.750	.484	2.625	1.500	1.125	1.625	5/8-18	26	9,713	.36
CM-12	CB-12	.7500	.875	.593	2.875	1.750	1.312	1.750	3/4-16	24	14,207	.57

* Grease fitting not available.
If Magnetic Particle Inspection is required, add suffix "M".
(Ex: CM-6M)

Units are supplied without grease fittings. When grease fittings are required, specify by adding suffixes as designated.

Z Zerk type fitting Ex: CM-6Z
F Flush type fitting Ex: CM-6F

Load ratings apply to rod ends without grease fittings. For load ratings with fittings, please consult our engineering department.



CW & CG Series Female Rod Ends

General Purpose - Economy

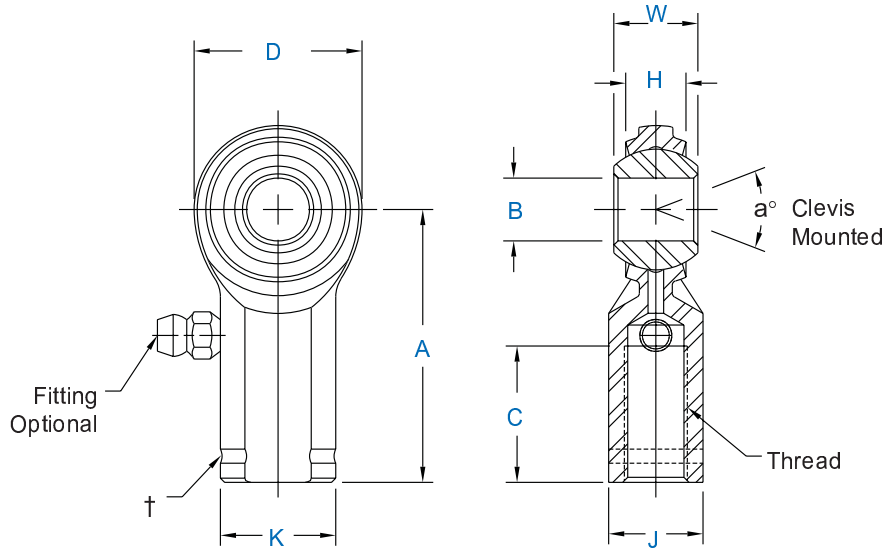

Specifications	
BODY	Low Carbon Steel, Protective Coated for Corrosion Resistance.
BALL	Sintered steel, Heat treated, Oil Impregnated.
ALTERNATE BALL	Alloy Steel, Heat Treated, Hard Chrome Plated.

Note: Units are **NOT** traceable and **NOT** magnetic particle inspected.

Rod End No.		DIMENSIONS IN INCHES										a° Misalgn. Angle	Ult. Static Radial Load Lbs.	Approx. Brg. Wt. Lbs.
Right Hand	Left Hand	B +.0025 -.0005	W ± .005	H Ref.	A ± .015	D ± .010	K ± .010	J ± .010	Ball Dia. Ref.	C +.062 -.031	Thread UNF-2B			
CW-3	CG-3	.1900	.312	.234	1.062	.625	.406	.312	.437	.500	10-32	20	2,079	.04
CW-4	CG-4	.2500	.375	.250	1.312	.750	.469	.375	.500	.687	1/4-28	27	3,208	.05
CW-5	CG-5	.3125	.437	.312	1.375	.875	.500	.437	.625	.687	5/16-24	22	3,824	.08
CW-6	CG-6	.3750	.500	.359	1.625	1.000	.687	.562	.719	.812	3/8-24	22	5,087	.13
CW-7	CG-7	.4375	.562	.406	1.812	1.125	.750	.625	.812	.937	7/16-20	21	6,385	.18
CW-8	CG-8	.5000	.625	.453	2.125	1.312	.875	.750	.937	1.062	1/2-20	20	9,096	.29
CW-10	CG-10	.6250	.750	.484	2.500	1.500	1.000	.875	1.125	1.375	5/8-18	26	9,713	.43
CW-12	CG-12	.7500	.875	.593	2.875	1.750	1.125	1.000	1.312	1.562	3/4-16	24	14,207	.65

* Grease fitting not available

† Left hand units have identification groove near end of shank.

If Magnetic Particle Inspection is required, add suffix "M".

(Ex: CW-6M)

Units are supplied without grease fittings. When grease fittings are required, specify by adding suffixes as designated.

Z Zerk type fitting

F Flush type fitting

Ex: CW-6Z

Ex: CW-6F



COM- & HCOM- Series
Spherical Bearings (PTFE Liners Available)¹

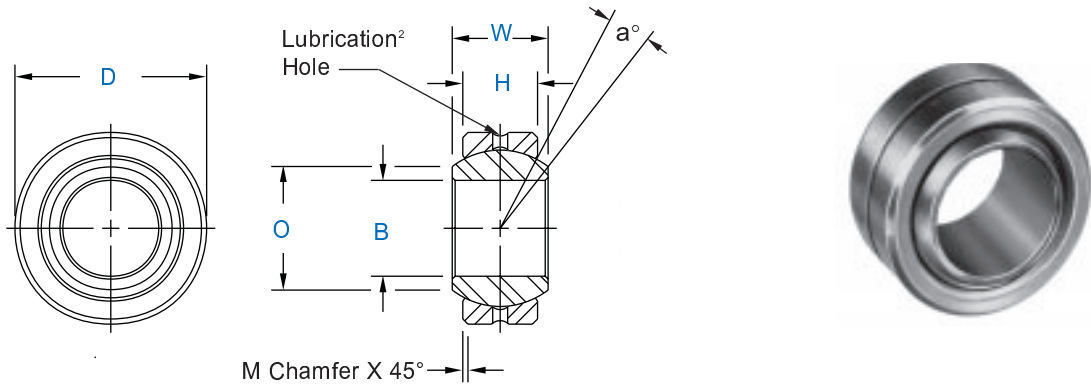

Specifications	
BALL	Through Hardened Steel, Heat Treated Hard Chrome Plated.
RACE (Outer Member)	Carbon Steel, Protective Coated for Corrosion Resistance

Note: Units are **NOT** traceable and **NOT** magnetic particle inspected.

SECTION THREE

AURORA NO.	DIMENSIONS IN MILLIMETERS							a° Misalign. Angle	Radial Static Load Capacity Lbs.	Approx. Brg. Wt. Lbs.
	B + .0015 - .0005	D + .0000 - .0007	H ± .005	W ± .005	O Flat Dia Ref.	M Chamfer Ref.	Ball Dia. Ref.			
COM-3	.1900	.5625	.218	.281	.293	.015	.406	11	3,250	.014
COM-4	.2500	.6562	.250	.343	.364	.022	.500	13.5	4,950	.022
COM-5	.3125	.7500	.281	.375	.419	.032	.562	12	6,475	.030
COM-6	.3750	.8125	.312	.406	.516	.032	.656	10	8,400	.038
COM-7	.4375	.9062	.343	.437	.530	.032	.687	8	9,453	.047
COM-8	.5000	1.0000	.390	.500	.640	.032	.813	9.5	13,250	.065
COM-9	.5625	1.0937	.437	.562	.710	.032	.906	9.5	16,630	.086
COM-10	.6250	1.1875	.500	.625	.780	.032	1.000	8.5	21,280	.110
COM-12	.7500	1.4375	.593	.750	.920	.044	1.187	9	31,920	.204
COM-14	.8750	1.5625	.703	.875	.980	.044	1.312	9.5	41,960	.263
*COM-16	1.0000	1.7500	.797	1.000	1.118	.044	1.500	10	55,200	.386
*HCOM-16	1.0000	2.0000	.781	1.000	1.360	.032	1.687	9	70,820	.553
*HCOM-19	1.1875	2.3750	.937	1.187	1.610	.032	2.000	8.5	100,730	.895
*HCOM-20	1.2500	2.3750	.937	1.187	1.610	.032	2.000	8.5	100,730	.895
*HCOM-24	1.5000	2.7500	1.094	1.375	1.860	.032	2.312	8.5	135,950	1.358
*HCOM-28	1.7500	3.1250	1.250	1.562	2.110	.044	2.625	8	176,370	1.948
*HCOM-32	2.0000	3.5000	1.750	1.750	2.360	.044	2.937	8.5	217,060	2.650

* Bore tolerance on these items is as follows - INCH: +.0025, -.0005.
If Magnetic Particle Inspection is required, add suffix "M" (Ex: COM-6M)

1 PTFE Liners use suffix T- Ex: COM-8T
2 PTFE Liners have no lubrication holes or groove in race.



**AIB, SIB, MIB and MIB-T Series
Spherical Bearings (PTFE Liners Available)¹**

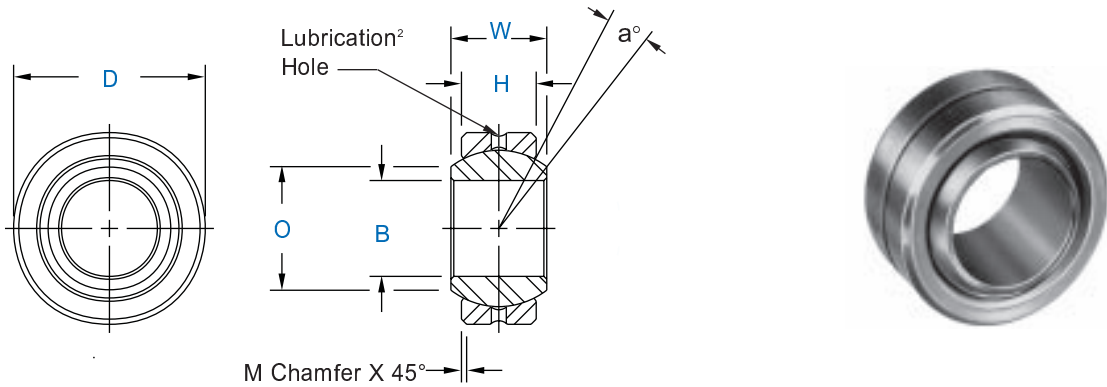

Specifications		
SERIES	BALL	RACE (OUTER MEMBER)
MIB-	Alloy steel, heat treated, hard chrome plated.	Carbon steel, I.D. protective coated for corrosion resistance, oil coated.
MIB-T ¹	Alloy steel, heat treated, hard chrome plated.	Carbon steel, PTFE Lined.
AIB-	Alloy steel, heat treated, hard chrome plated.	Alloy steel, heat treated, I.D. protective coated for corrosion resistance, oil coated.
SIB-	Alloy steel, heat treated, hard chrome plated.	Stainless steel, heat treated, oil coated.

Note: Units are **NOT** traceable and **NOT** magnetic particle inspected.

AURORA NO.				DIMENSIONS IN INCHES							a° Misalign. Angle	Radial Static Load Capacity Lbs.		Approx. Brg. Wt. Lbs.
				B	D	H	W	O	M	Ball Dia. Ref.		MIB-MIB-T	AIB-SIB	
				+ .0015 - .0005	+ .0000 - .0007	± .005	± .005	Flat Dia. Ref.	Chamfer Ref.					
AIB-3	SIB-3	MIB-3	MIB-3T	.1900	.5312	.250	.312	.307	.020	.437	10.5	4,370	6,555	.016
AIB-4	SIB-4	MIB-4	MIB-4T	.2500	.6094	.281	.375	.331	.020	.500	14.5	5,620	8,430	.023
AIB-5	SIB-5	MIB-5	MIB-5T	.3125	.7500	.344	.437	.448	.020	.625	11.0	8,600	12,900	.039
AIB-6	SIB-6	MIB-6	MIB-6T	.3750	.8437	.406	.500	.516	.020	.719	9.5	11,677	17,516	.059
AIB-7	SIB-7	MIB-7	MIB-7T	.4375	1.0000	.437	.562	.587	.020	.812	11.0	14,194	21,291	.079
AIB-8	SIB-8	MIB-8	MIB-8T	.5000	1.0937	.500	.625	.699	.020	.937	9.5	18,740	28,110	.110
AIB-10	SIB-10	MIB-10	MIB-10T	.6250	1.3125	.562	.750	.839	.030	1.125	12.0	25,290	37,935	.165
AIB-12	SIB-12	MIB-12	MIB-12T	.7500	1.5000	.687	.875	.978	.030	1.312	10.0	32,448	48,672	.252
AIB-14	SIB-14	MIB-14	MIB-14T	.8750	1.6250	.750	.875	1.061	.035	1.375	6.0	39,653	58,653	.350
AIB-16*	SIB-16*	MIB-16*	MIB-16T*	1.0000	2.1250	1.000	1.375	1.275	.060	1.875	15.0	60,000	90,000	.788

* Bore tolerance on these items is as follows - INCH: +.0035, -.0005.
If Magnetic Particle Inspection is required, add suffix "M" (Ex: AIB-6M)

¹ PTFE Liners use suffix T - Ex: AIB-8T
² PTFE Liners have no lubrication holes or groove in race.

SECTION THREE



Suggested Housing Bores Spherical Bearings

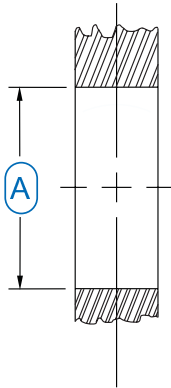

RADIAL STATIC LOAD CAPACITY

These loads are maximum static based on maximum permanent set in the bearing race of 0.2% of the ball diameter. If a greater permanent set can be allowed or if alternate race materials are used consult our engineering department for change factors.

AXIAL STATIC LOAD CAPACITY

These loads are approximately 20% of the radial loads listed when the load bearing surfaces are properly supported.

ALTERNATE RACE AND BALL MATERIALS

Materials other than those listed can be incorporated in bearings manufactured by Aurora Bearing Company. Stainless steels, to improve corrosion resistance, and heat treated alloy steels, to increase wear life, are frequently used in special applications.

PTFE lined races are also available in this series to provide service requiring no relubrication and improved frictional characteristics. Tables are representative of Metal to Metal parts, please consult our engineering department for PTFE lined parts.

COM & HCOM Series

Bearing Series COM HCOM	DIMENSIONS IN INCHES				
	A Suggested Housing Bore For Press Fit of Spherical Bearings				
	Bearing Outside Diameter +.0000 -.0007	Steel Housing		Aluminum Housing	
		Max.	Min.	Max.	Min.
3	.5625	.5619	.5614	.5618	.5612
4	.6562	.6556	.6551	.6555	.6549
5	.7500	.7494	.7489	.7493	.7487
6	.8125	.8119	.8114	.8118	.8112
7	.9062	.9056	.9051	.9055	.9049
8	1.0000	.9994	.9989	.9993	.9987
9	1.0937	1.0931	1.0925	1.0930	1.0923
10	1.1875	1.1869	1.1863	1.1868	1.1861
12	1.4375	1.4369	1.4363	1.4368	1.4361
14	1.5625	1.5619	1.5613	1.5618	1.5611
16	1.7500	1.7494	1.7488	1.7493	1.7485
16	2.0000	1.9994	1.9988	1.9993	1.9985
19	2.3750	2.3744	2.3738	2.3743	2.3735
20	2.3750	2.3744	2.3738	2.3743	2.3735
24	2.7500	2.7494	2.7488	2.7493	2.7485
28	3.1250	3.1244	3.1238	3.1243	3.1235
32	3.5000	3.4994	3.4988	3.4993	3.4985

MIB, AIB, SIB, MIB-T Series

Bearing Series MIB AIB SIB MIB-T	DIMENSIONS IN INCHES				
	A Suggested Housing Bore For Press Fit of Spherical Bearings				
	Bearing Outside Diameter +.0000 -.0007	Steel Housing		Aluminum Housing	
		Max.	Min.	Max.	Min.
3	.5312	.5306	.5301	.5305	.5299
4	.6094	.6088	.6083	.6087	.6081
5	.7500	.7494	.7489	.7493	.7487
6	.8437	.8431	.8426	.8430	.8424
7	1.0000	.9994	.9989	.9993	.9987
8	1.0937	1.0931	1.0925	1.0930	1.0923
10	1.3125	1.3119	1.3113	1.3118	1.3111
12	1.5000	1.4994	1.4988	1.4993	1.4986
14	1.6250	1.6244	1.6238	1.6243	1.6235
16	2.1250	2.1244	2.1238	2.1243	2.1235

Dimensions given in the above tables are for bearings fabricated of standard race materials. Should other materials be used, consult our engineering department for modification of these dimensions.



INSTALLATION OF SPHERICAL BEARING

FIGURE 1

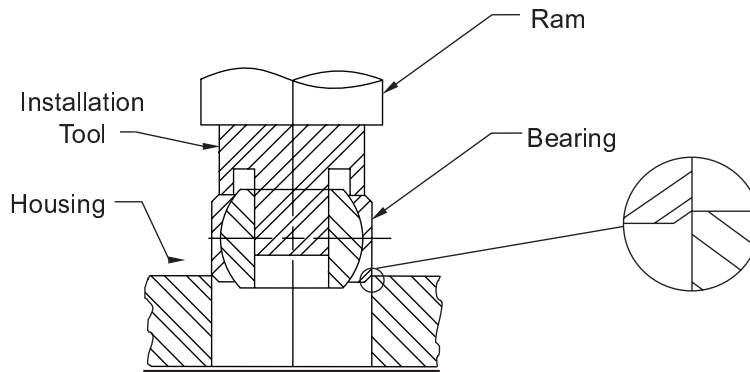

SPHERICAL BEARING INSTALLATION

Proper installation of the bearing is important to prevent bearing failure as well as housing damage. Under no circumstances should a tool that induces shock or impact to the bearing be used. The use of an arbor press or hydraulic press is recommended. A tool as shown above (Figure 1) is advised. All force is to be applied on the bearing race face (not on ball). A lead chamfer or radius on the bearing and/or housing is vital.

HOUSING CHAMFER - GROOVED BEARINGS

CHAMFER FOR GROOVE TYPES	
GROOVE TYPE A	.020 ± .005
GROOVE TYPE B	.030 ± .005
GROOVE TYPE C	.050 ± .005

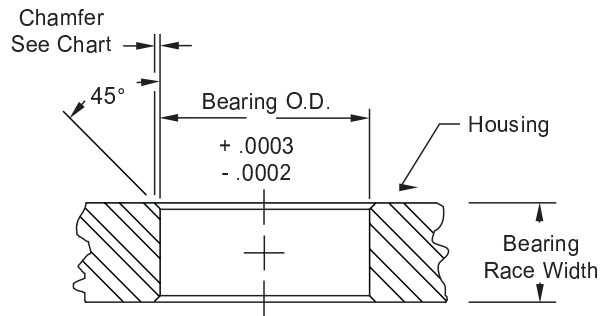

STAKING GROOVE TYPES

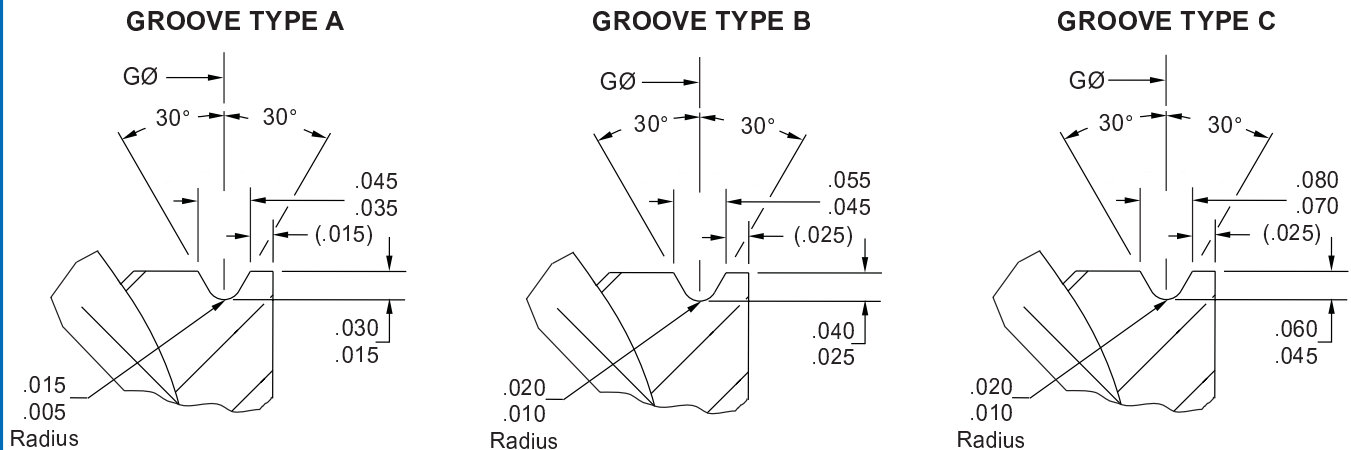



INSTALLATION OF SPHERICAL BEARING WITH STAKING GROOVES TOOLS AND STAKING METHODS

FIGURE 2

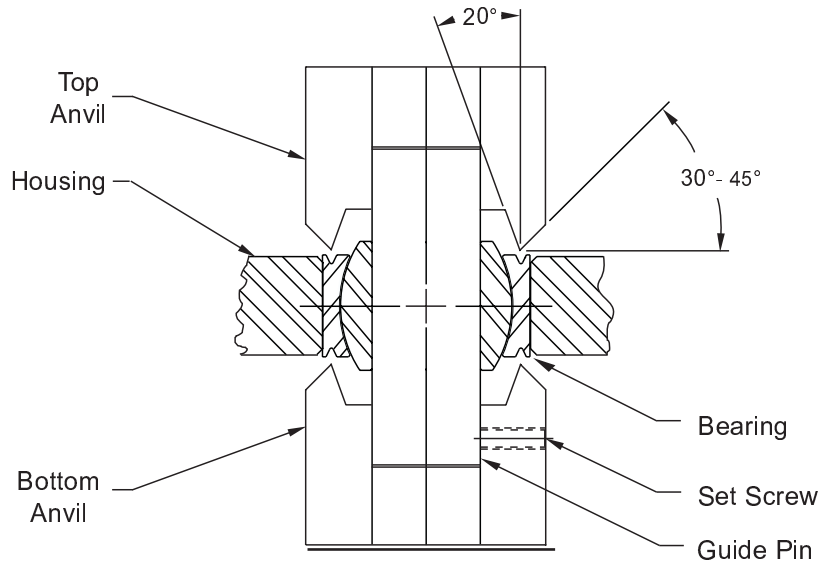

SPHERICAL BEARING INSTALLATION

The bearings have grooves in each side of the bearing race face, leaving a small lip. Staking tools (as shown above in Figure 2) are then used to stake the lip over the chamfer edges of the housing. A typical arrangement consists of two identical anvils and one guide pin which is secured by a set screw in the bottom anvil.

PROCEDURES

1. Install bearing into housing as shown in Figure 1 and position bearing symmetrical about housing centerline.
2. Align bearing with staking tool and guide pin as shown in Figure 2.
3. A trial stake assembly should be made to determine staking force necessary to meet thrust load requirements. Proper staking force is required because excessive pressure could result in bearing distortion along with life.
4. Pressure established by trial assembly is to be applied. After first stake is completed rotate assembly 90° and re-apply. Repeat operation through a minimum of three rotations to insure 360° uniformity of stake.
5. After staking, a slight gap may exist between race lip and housing chamfer. This slight gap (shown below) may not be cause for rejection if bearing meets or exceeds thrust loads.

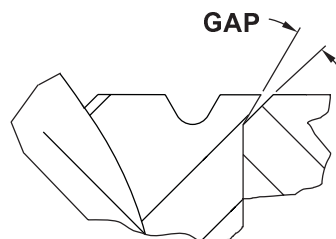



Liner Designation	AT1400	AT2100	AT2300	AT3200
Construction	PTFE/Dacron Laminate	PTFE/Fiberglass Weave	PTFE/Dacron Weave	PTFE/Nomex Laminate
Thickness (in.)	.011 - .013	.010 - .012	.013 - .015	.014 - .016
Temperature (°F)	-65° to 350°	-65° to 250°	-65° to 250°	-65° to 350°
Static Limit Load	80,000 PSI	60,000 PSI	60,000 PSI	80,000 PSI
Stiffness	Medium to High	Medium	Low	Medium to High
Typical Performance	37,500 PSI @±25° & 10-20 cpm .0045 wear max.@ 25,000 cycles	25,000 PSI @±25° & 10-20 cpm .0060 wear max.@ 5,000 cycles	Contact Aurora Engineering Department	37,500 PSI @±25° & 10-20 cpm .0045 wear max.@ 25,000 cycles
Dynamic Capabilities	Light to heavy, unidirectional or alternating loads. Low speed, intermittent to continuous misalignment, intermittent to continuous oscillation.	Light unidirectional loads. Low speed, intermittent to continuous misalignment, intermittent to continuous oscillation	Light to medium, alternating or reversing loads. Medium to High speed, intermittent to continuous misalignment, intermittent to continuous oscillation.	Light to heavy, unidirectional or alternating loads. Low speed, intermittent to continuous misalignment, intermittent to continuous oscillation.
Comments	Good multi-purpose system	Excellent stick-slip properties Usually recommended for high splash or underwater applications	Excellent stick-slip properties Good vibratory conditions	Highest performance characteristics for all applications Qualified to SAE-AS81820



MAJOR SPECIFICATION APPROVALS

MILITARY STANDARDS

MS14101	M81935/1	M81934/1
MS14102	M81935/2	M81934/2
MS14103		
MS14104		

BOEING SPECIFICATIONS

BACB10A	BACB10ES	BACB10J
BACB10AB	BACB10FH	BACB10W
BACB10AG	BACB10FJ	BACB10X
BACB10CL	BACB10GB	BACB10Y
BACB10CN	BACB10GC	BACB10Z
BACB10ER	BACB10GD	
10-60516	60B10009	60B80103
10-60545	60B10024	S012T235
10-60779	60B50350	S012T237
60B00180	60B50351	162T4005
60B10007		

AIRBUS SPECIFICATIONS

ABS0569	ABS0570	ABS0571
---------	---------	---------

LOCKHEED SPECIFICATIONS

C11653	C631	C7537
C20308	C633	C7546
C2959	C657	C7547
C347	C658	C7937
C555	C7504	C806



INCH/METRIC CONVERSION TABLE

INCH		MM.	INCH		MM.	INCH		MM.	INCH		MM.
FRACT.	DEC.		FRACT.	DEC.		FRACT.	DEC.		FRACT.	DEC.	
	0.0004	0.001	17/64	0.2656	6.746		0.6693	17.0		1.3780	35.0
	0.00039	0.01		0.2756	7.0	43/64	0.6719	17.066		1.4173	36.0
	0.0010	0.025	9/32	0.2812	7.1437	11/16	0.6875	17.4625	1 1/2	1.5000	38.1
	0.0020	0.051	19/64	0.2969	7.5406	45/64	0.7031	17.859		1.5354	39.0
	0.0030	0.0762	5/16	0.3125	7.9375		0.7086	18.0		1.5748	40.0
	0.00394	0.1		0.3150	8.0	23/32	0.7187	18.256		1.6535	42.0
	0.0050	0.1270	21/64	0.3281	8.334	47/64	0.7334	18.653	1 3/4	1.7500	44.45
	0.00984	0.25	11/32	0.3437	8.731		0.7480	19.0		1.7717	45.0
	0.0100	0.254		0.3543	9.0	3/4	0.7500	19.05		1.8898	48.0
1/64	0.0156	0.396	23/64	0.3594	9.1281	49/64	0.7656	19.446		1.9685	50.0
1/32	0.0312	0.793	3/8	0.3750	9.525	25/32	0.7815	19.843	2	2.0000	50.8
	0.03937	1.0	25/64	0.3906	9.9219		0.7874	20.0		2.0472	52.0
3/64	0.0469	1.191		0.3937	10.0	51/64	0.7969	20.240		2.1654	55.0
	0.0591	1.5	13/32	0.4062	10.318	13/16	0.8125	20.6375		2.2047	56.0
1/16	0.0625	1.5875	27/64	0.4219	10.716		0.8268	21.0	2 1/4	2.2500	57.15
5/64	0.0781	1.984		0.4331	11.0	53/64	0.8281	21.034		2.3622	60.0
	0.0787	2.0	7/16	0.4375	11.1125	27/32	0.8437	21.431	2 1/2	2.5000	63.5
3/32	0.0937	2.381	29/64	0.4531	11.509	55/64	0.8594	21.828		2.5197	64.0
	0.0984	2.5	15/32	0.4687	11.906		0.8661	22.0	2 3/4	2.7500	69.85
	0.1000	2.54		0.4724	12.0	7/8	0.8750	22.225		2.8346	72.0
7/64	0.1094	2.778	31/64	0.4844	12.303	57/64	0.8906	22.621		2.9528	75.0
	0.1181	3.0	1/2	0.5000	12.7		0.9055	23.0	3	3.0000	76.2
1/8	0.1250	3.175		0.5118	13.0	29/32	0.9062	23.018		3.1496	80.0
	0.1387	3.5	33/64	0.5156	13.096	59/64	0.9219	23.416	3 1/4	3.2500	82.55
9/64	0.1406	3.571	17/32	0.5312	13.493	15/16	0.9375	23.8125	3 1/2	3.5000	88.9
5/32	0.1562	3.968	35/64	0.5469	13.891		0.9449	24.0		3.5433	90.0
	0.1575	4.0		0.5512	14.0	61/64	0.9531	24.209	3 3/4	3.7500	95.25
11/64	0.1719	4.366	9/16	0.5625	14.2875	31/32	0.9687	24.606		3.9370	100.0
	0.1772	4.5	37/64	0.5781	14.684		0.9843	25.0	4	4.0000	101.6
3/16	0.1875	4.7625		0.5906	15.0	63/64	0.9844	25.003	4 1/4	4.2500	107.95
	0.1969	5.0	19/32	0.5937	15.081	1	1.0000	25.4		4.3307	110.0
13/64	0.2031	5.159	39/64	0.6094	15.478		1.0630	27.0	4 1/2	4.5000	114.3
7/32	0.2187	5.556	5/8	0.6250	15.875		1.1024	28.0		4.7244	120.0
15/64	0.2334	5.953		0.6299	16.0		1.1811	30.0	4 3/4	4.7500	120.65
	0.2362	6.0	41/64	0.6406	16.271	1 1/4	1.2500	31.75	5	5.0000	127.0
1/4	0.2500	6.35	21/32	0.6562	16.668		1.2992	33.0	5 1/2	5.5000	139.7

INCH/METRIC CONVERSION FACTORS

Inches x 25.4 = Millimeters

Millimeters x .03937 = Inches

Sq. Inches x 6.4515 = Sq. Centimeters

Sq. Centimeters x .155 = Sq. Inches

Pounds x .4536 = Kilograms

Kilograms x 2.2046 = Pounds

Lbs. per In.² x .0703 = kg per cm²

kg per cm² x 14.2231 = Lbs. per In.²

Pounds(Force) x 4.448 = Newtons

Newtons x .2248 = Pounds(Force)

Temperature Conversion (Approximate)

Degrees C = (Degrees F - 32) (.5556)

Degrees F = (Degrees C) (1.8) + 32

SPECIALLY DESIGNED



ROD ENDS, BEARINGS & BUSHINGS

*To meet the requirements of airframe manufacturers.
Let us design specials to meet your specific applications.*



**AURORA BEARING CO.
970 SOUTH LAKE ST.
AURORA, IL 60506
USA**

**PHONE: (630) 859-2030
FAX: (630) 859-0971
www.aurorabearing.com**

e-mail: aurora_rodends@aurorabearing.com