

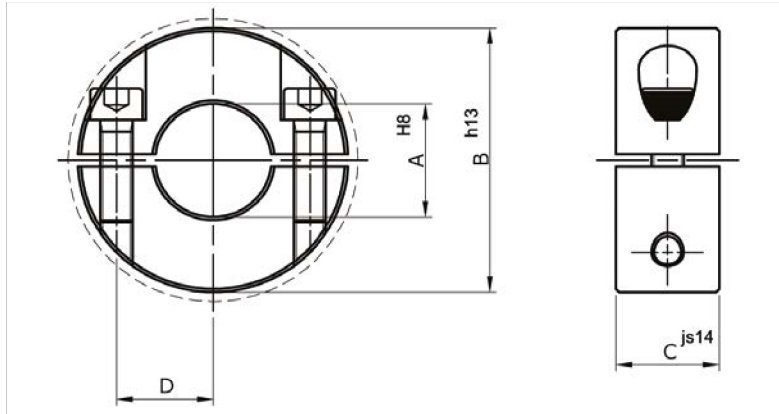

## SPLIT SHAFT COLLARS IN 2 PARTS



Reference	A	B	C	D	Screw	Kg
BAG 4 / 2 ..	4	16	9	5,5	M3 x 8	0,011
BAG 5 / 2 ..	5	16	9	5,5	M3 x 8	0,011
BAG 6 / 2 ..	6	16	9	5,5	M3 x 8	0,010
BAG 8 / 2 .. C	8	25	10		M4 x 15	0,012
BAG 10 / 2 .. C	10	32	10		M4 x 15	0,024
BAG 12 / 2 .. C	12	32	10		M4 x 15	0,039
BAG 14 / 2 ..	14	30	11	11,0	M4 x 12	0,043
BAG 15 / 2 .. C	15	40	12		M5 x 20	0,068
BAG 16 / 2 ..	16	34	13		M5 x 14	0,065
BAG 18 / 2 .. C	18	45	12		M5 x 20	0,071
BAG 19 / 2 ..	19	40	15	14,7	M6 x 16	0,104
BAG 20 / 2 .. C	20	45	12		M5 x 20	0,101
BAG 22 / 2 ..	22	42	15	16,0	M6 x 16	0,107
BAG 23 / 2 ..	23	45	15	17,5	M6 x 16	0,127
BAG 24 / 2 .. C	24	50	12		M5 x 20	0,122
BAG 25 / 2 .. C	25	50	12		M5 x 20	0,120
BAG 26 / 2 ..	26	48	15	19,0	M6 x 18	0,139
BAG 28 / 2 .. C	28	56	12		M5 x 20	0,128
BAG 30 / 2 .. C	30	56	12		M5 x 20	0,171
BAG 32 / 2 .. C	32	56	12		M5 x 20	0,161
BAG 35 / 2 .. C	35	63	12		M5 x 20	0,172
BAG 36 / 2 ..	36	57	15	23,2	M6 x 18	0,169
BAG 38 / 2 .. C	38	63	12		M5 x 20	0,183
BAG 40 / 2 .. C	40	70	14		M6 x 20	0,172
BAG 45 / 2 .. C	45	80	14		M6 x 20	0,360
BAG 48 / 2 ..	48	78	19	32,0	M8 x 25	0,414
BAG 50 / 2 .. C	50	80	14		M6 x 20	0,386
BAG 55 / 2 ..	55	82	19	34,2	M8 x 25	0,395
BAG 60 / 2 .. C	60	100	16		M8 x 20	0,440
BAG 70 / 2 .. C	70	110	20		M10 x 25	0,495
BAG 80 / 2 ..	80	125	20		M10 x 25	0,550

.. add PH for phosphatised steel / ZN for galvanized steel / IN for stainless steel  
 "C" only with PH